

SNS COLLEGE OF TECHNOLOGY

**An Autonomous Institution
Coimbatore-35**



Department of Electrical and Electronics Engineering

23EEE307 – Embedded System Design

UNIT 2: Hardware Architecture of Embedded Systems

Embedded Networking: Introduction

Network Connectivity Challenges



Device Interoperability

Heterogeneous device compatibility



Data Transmission Reliability

Packet loss & corruption risks



Network Scalability

Expanding device networks



Real-time Constraints

Time-critical applications



Resource Limitations

Power & memory constraints

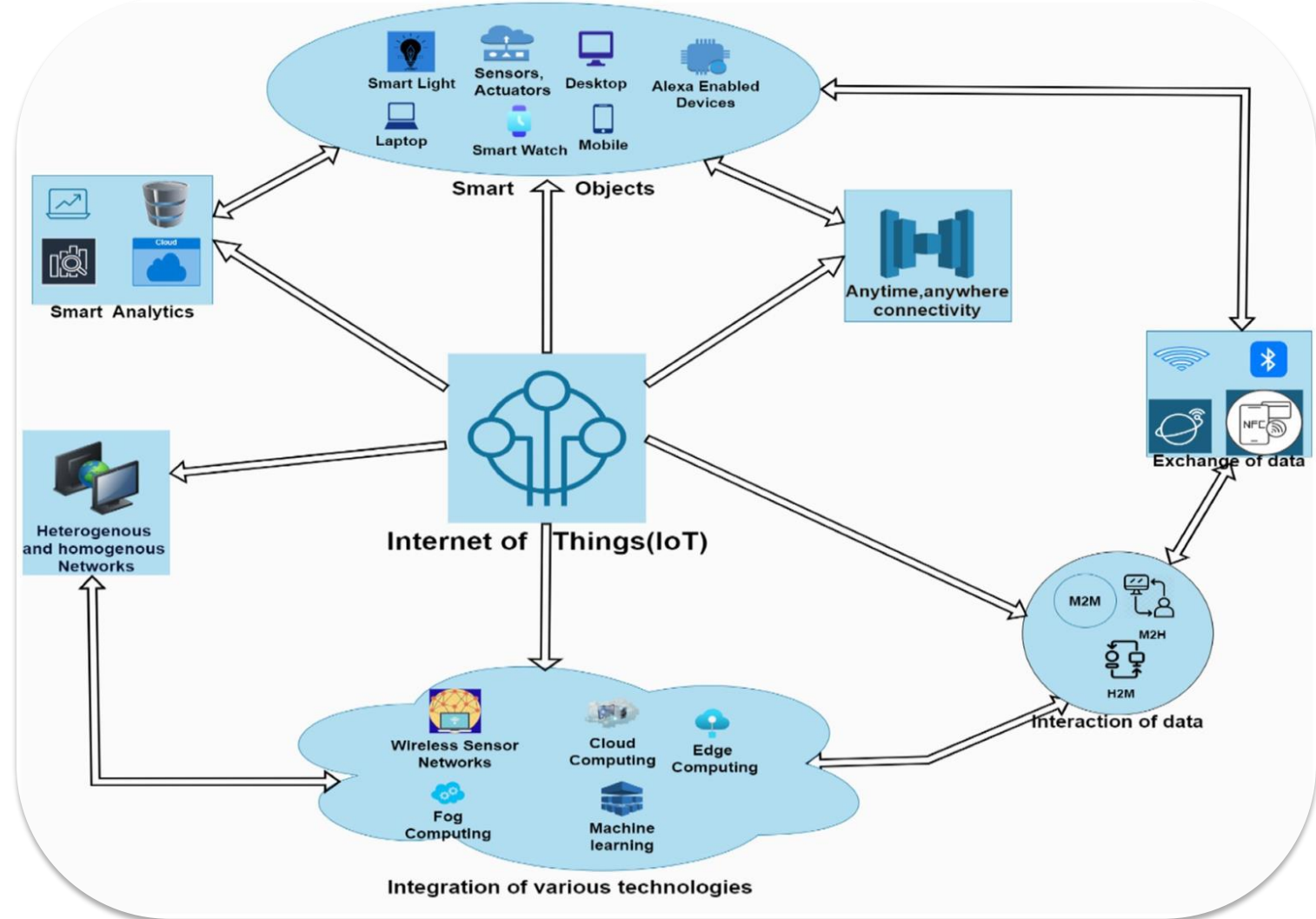

Core Problem

Enabling efficient data exchange in resource-constrained environments

- Resource-constrained environments
- Low-power operation requirements
- Secure data transmission

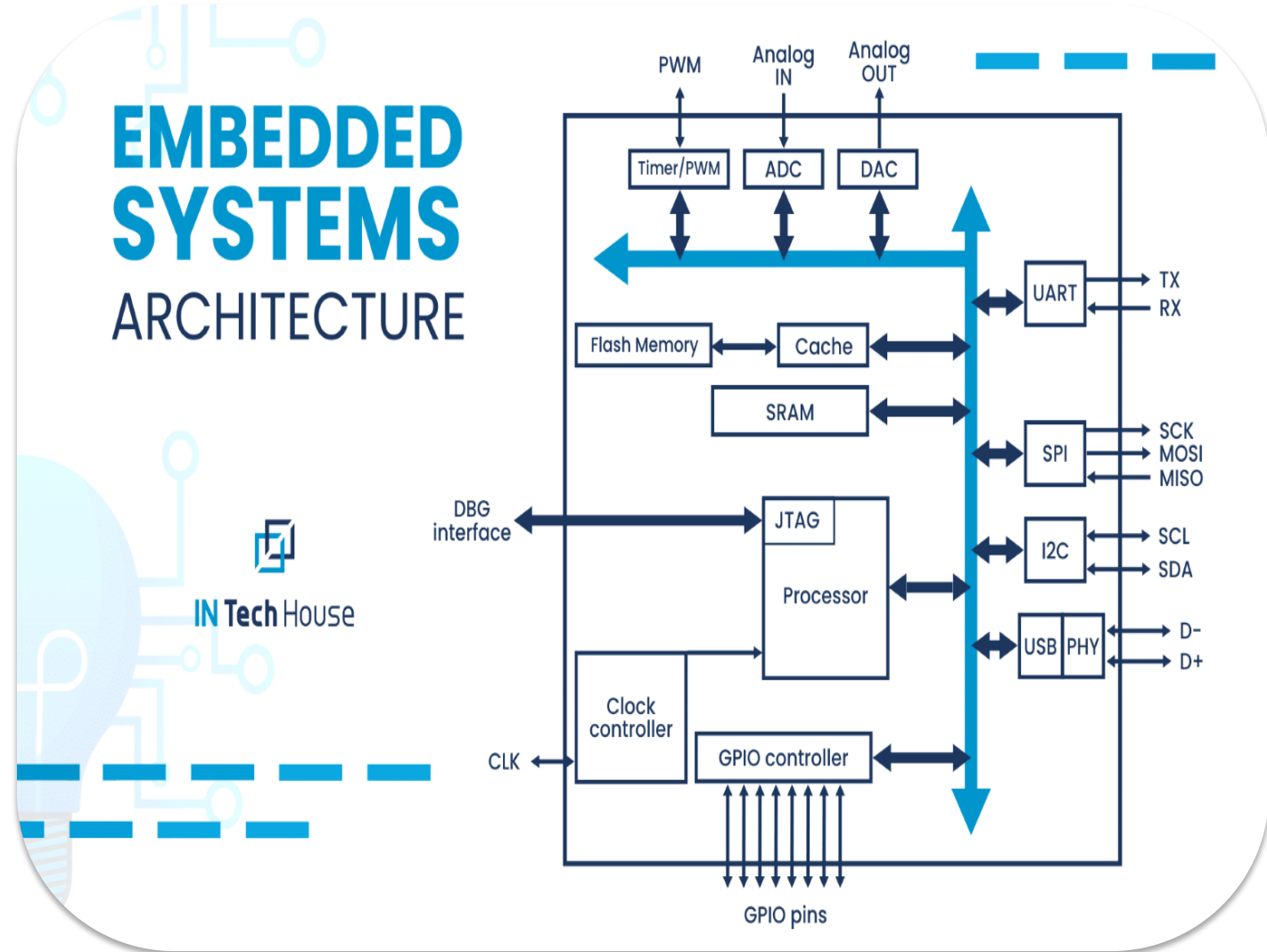

Solution Approaches

Ethernet • CAN • RS-485

Wi-Fi
Bluetooth
Zigbee
LoRaWAN

Layered architecture implementations

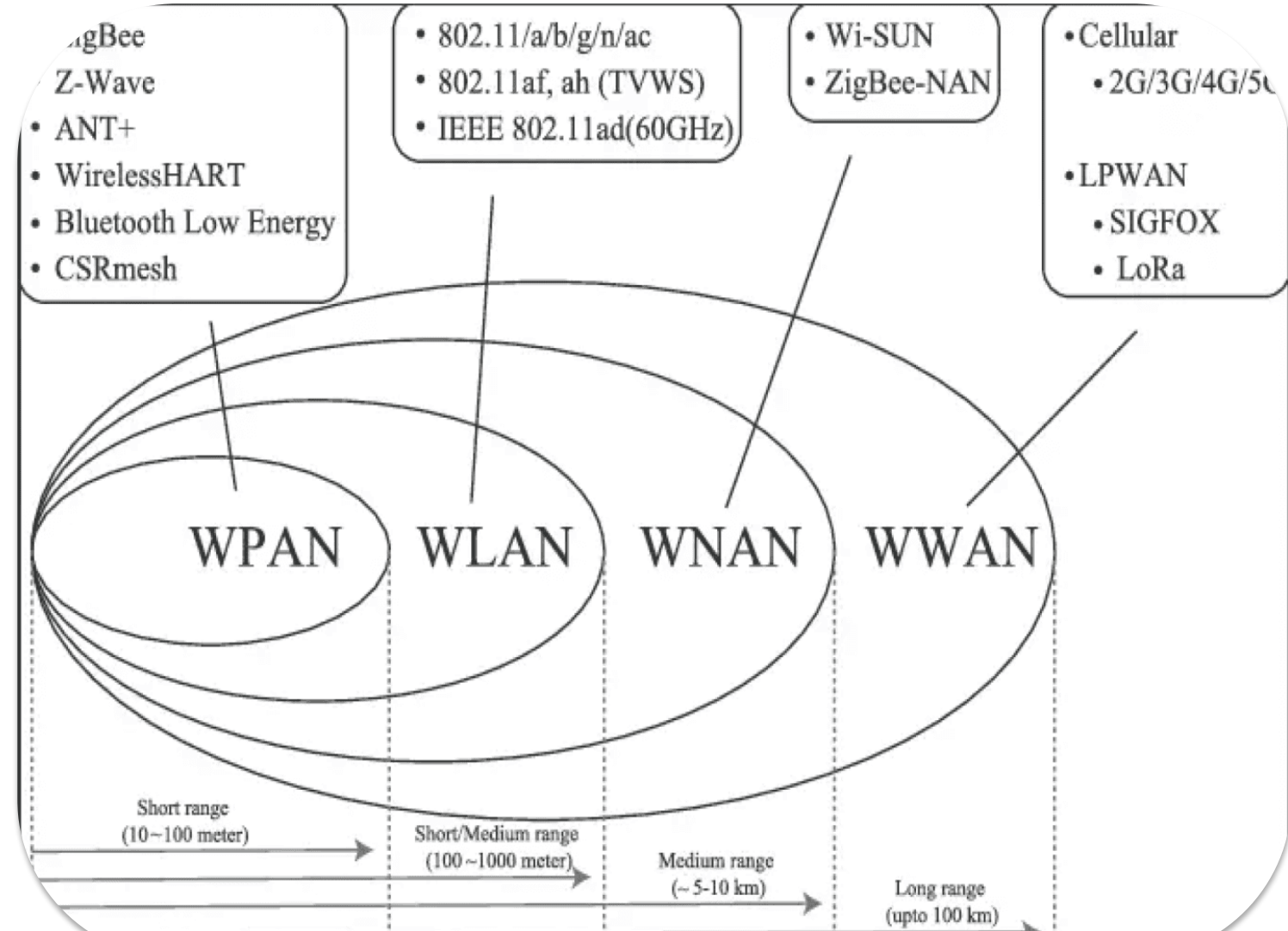

Network Architecture



Network Layers

Physical • Data Link • Network • Transport • Application



Protocol Stack

Layered implementation architecture



Device Communication

Peer-to-peer data exchange models

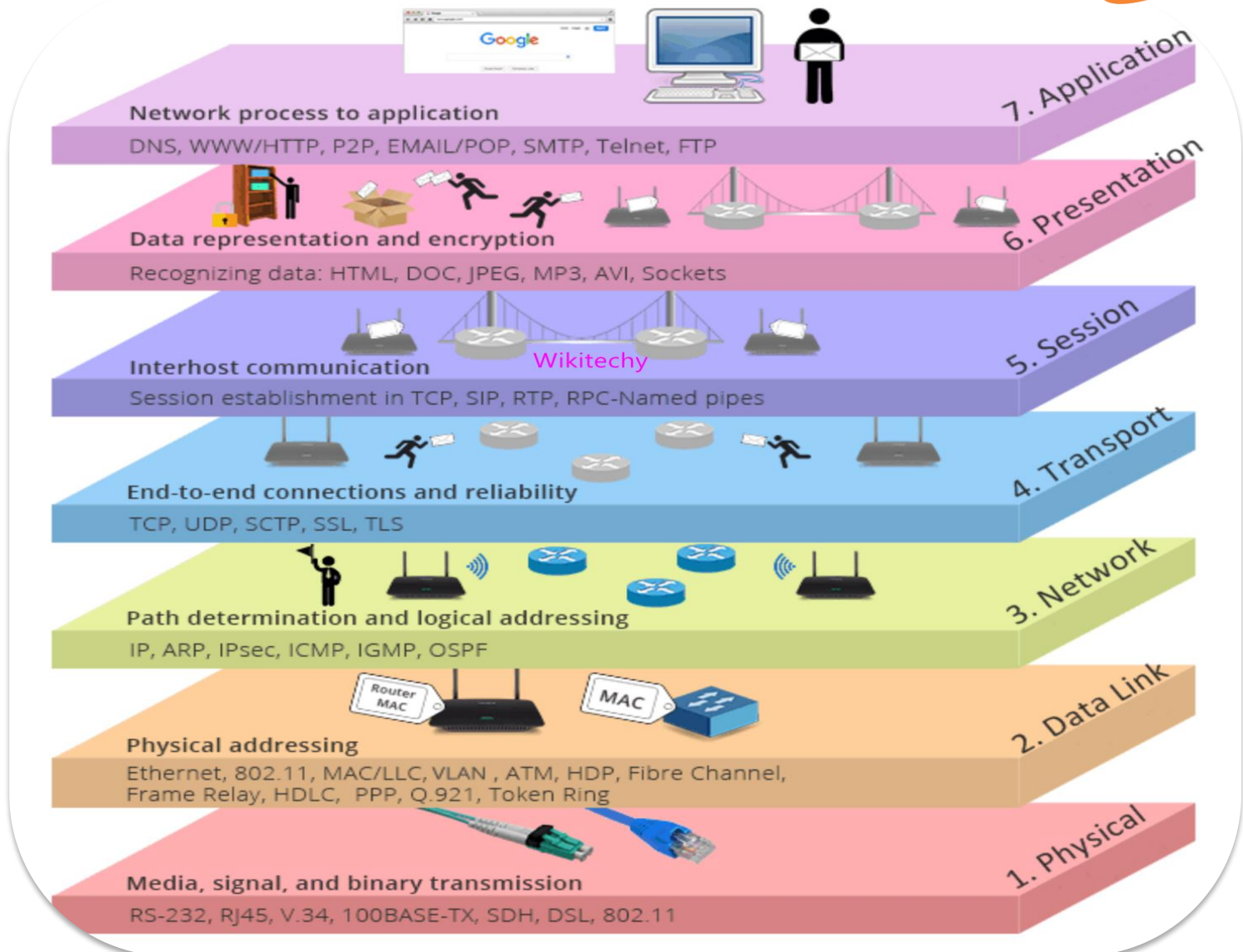

Performance Evaluation

Bandwidth Utilization
Data transfer capacity analysis

Latency Analysis
Response time measurement

Throughput Measurement
Effective data rate testing

Power Consumption
Energy efficiency metrics

Reliability Testing
Error rate & stability verification

Latency vs. Throughput Trade-offs

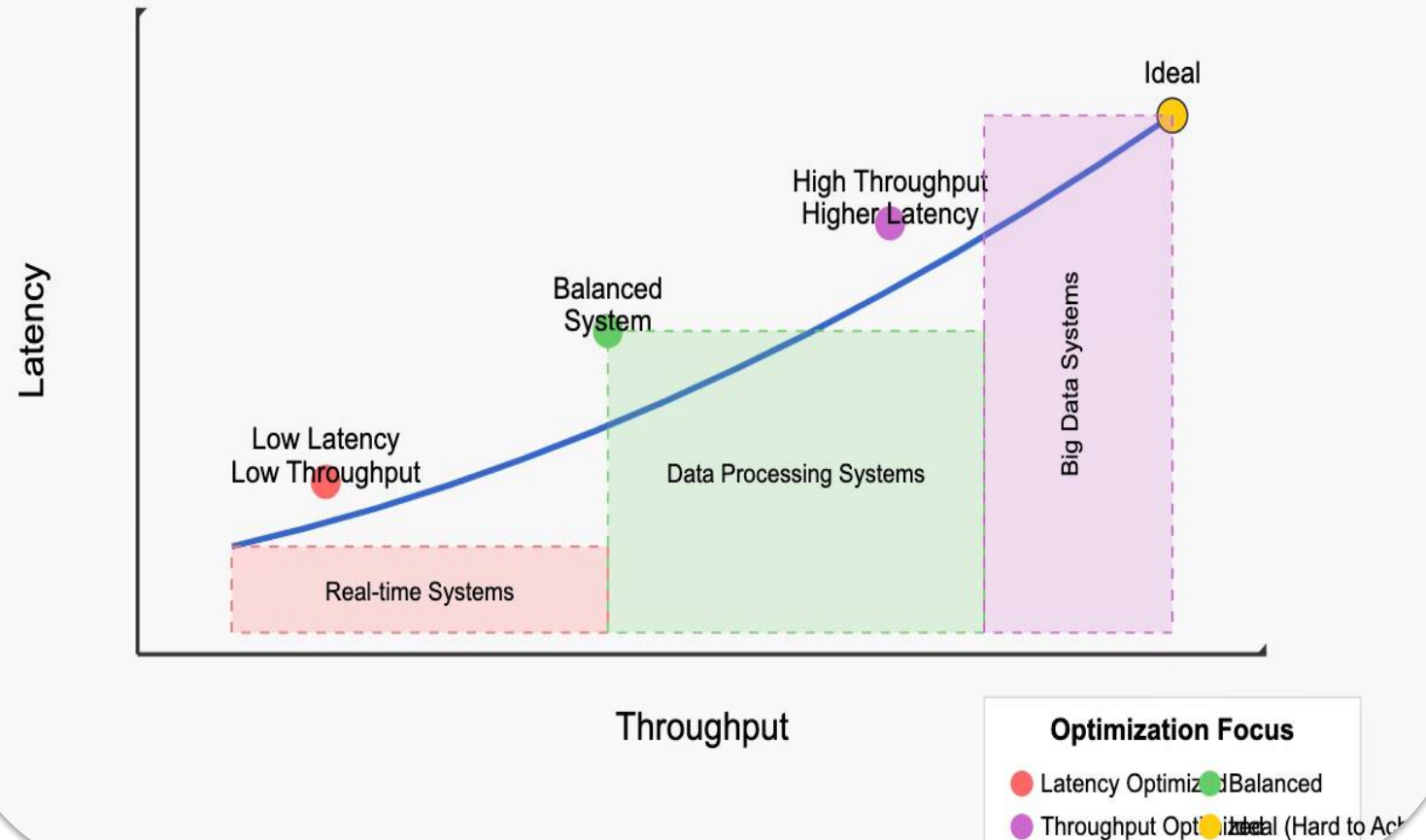

Key Mechanisms

- Packet Switching**
Data packet routing & forwarding
- Routing Protocols**
Path selection algorithms
- Error Detection & Correction**
Data integrity verification
- Security Features**
Encryption & authentication
- Network Management**
Monitoring & control systems

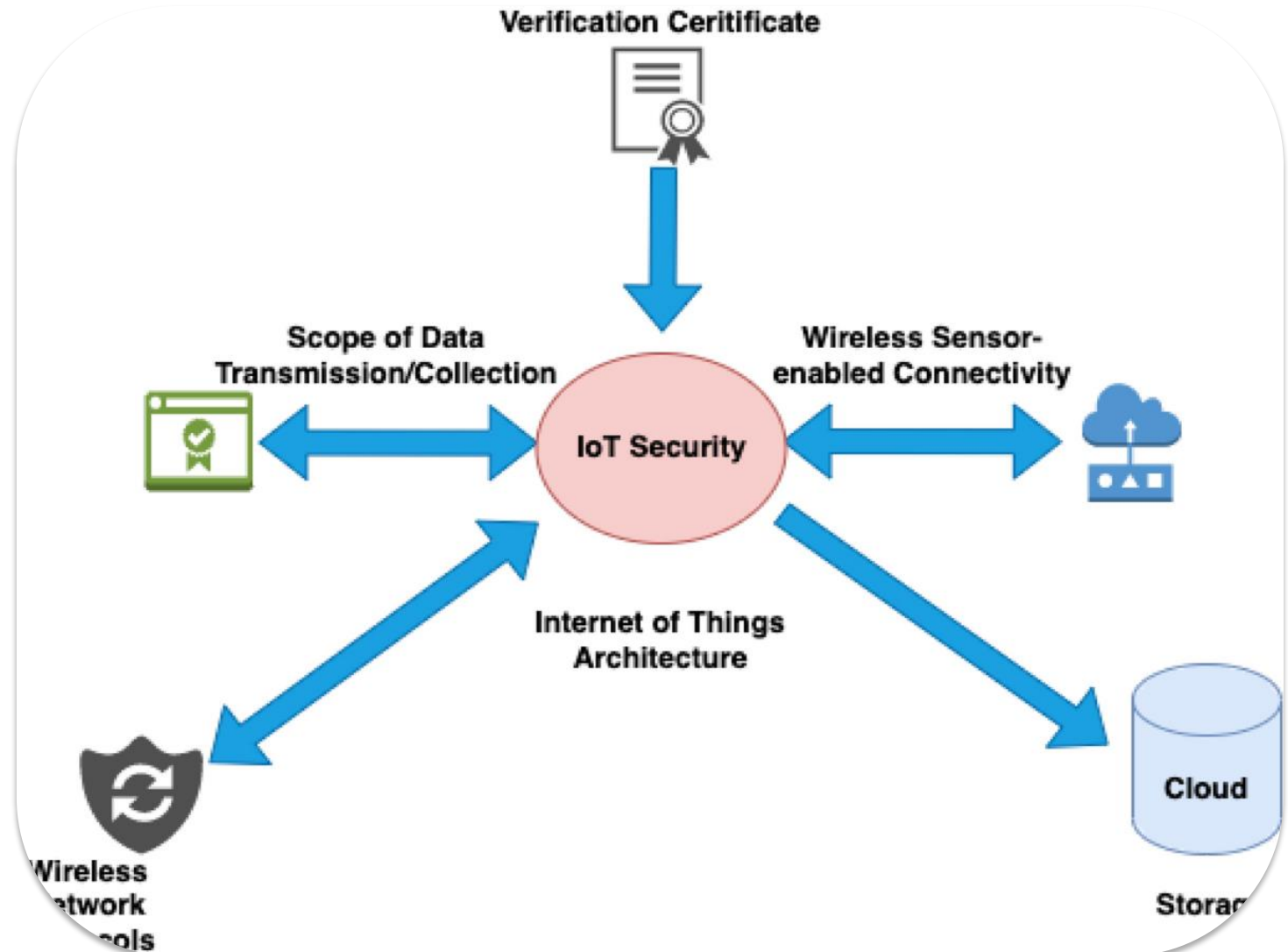

Real-World Implementations

Smart Homes & Buildings

Automated control systems

Industrial IoT & Automation

Factory 4.0 implementations

Automotive Networks

Vehicle-to-everything communication

Medical Devices

Healthcare IoT solutions

Smart Cities

Urban infrastructure networks

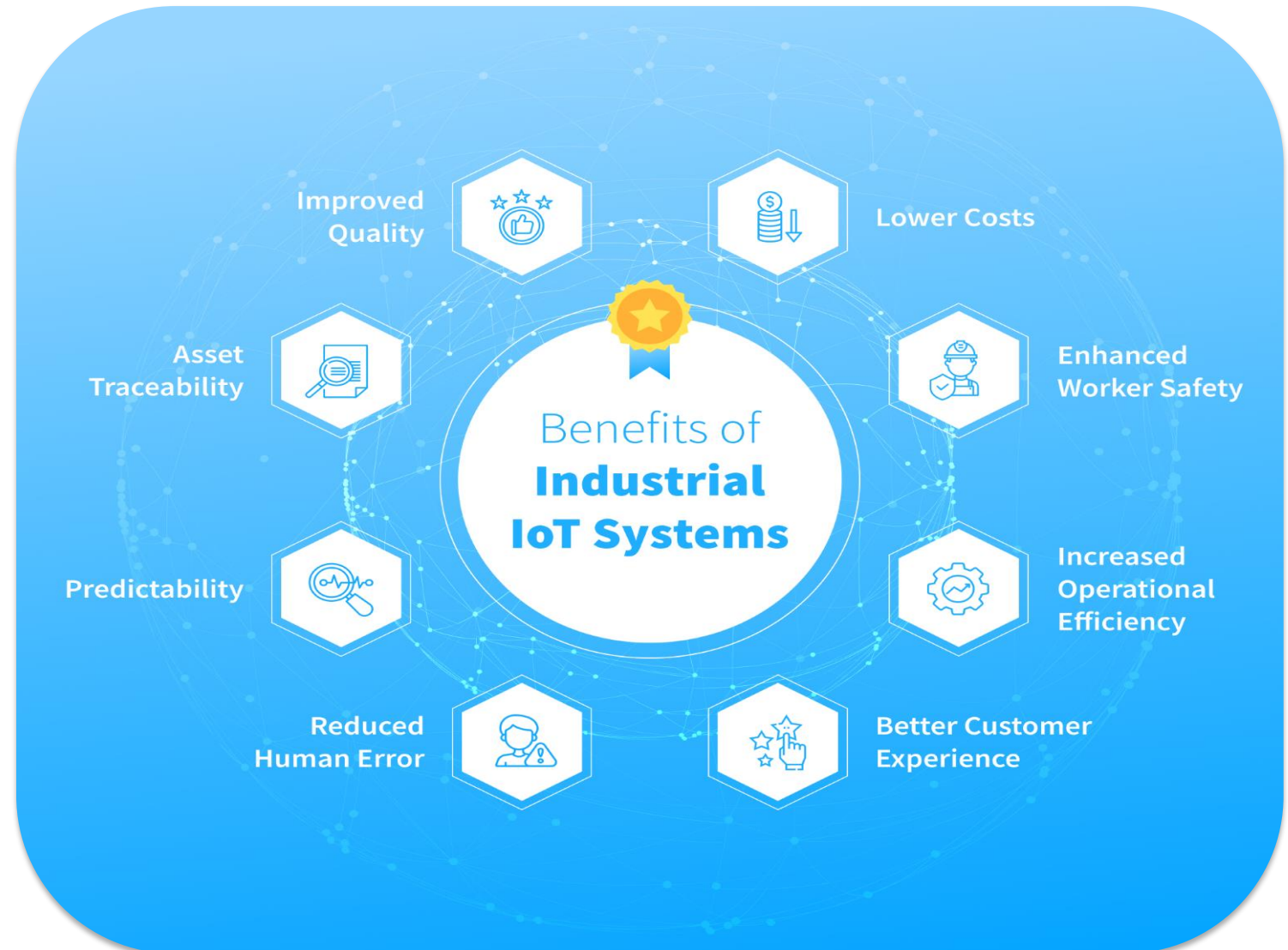

Assessment Questions



Conceptual Questions

Questions 1-2



Application Questions

Questions 3-4



Design Question

Question 5

1

What are the key differences between wired and wireless embedded networking protocols?

2

Explain the role of each layer in the network protocol stack.

3

Design a network architecture for a smart home with 20 IoT devices using appropriate protocols.

4

Select and justify networking protocols for an industrial automation system requiring real-time control.

5

Propose a hybrid networking solution that balances power consumption, bandwidth, and reliability for a remote environmental monitoring station with 50 sensors.