



Lecture 4



Primary tillage implements- disc plough (types and trouble shooting), Chisel plough, subsoiler

&

Ploughing of land and Methods of ploughing

Disc Plough: A plough, which cuts, turns and breaks furrow slices by means of separately mounted large steel discs.

Designed with a view of reduce friction by making a rolling plough bottom instead of sliding plough bottom.

Works well in conditions where mbp does not work.

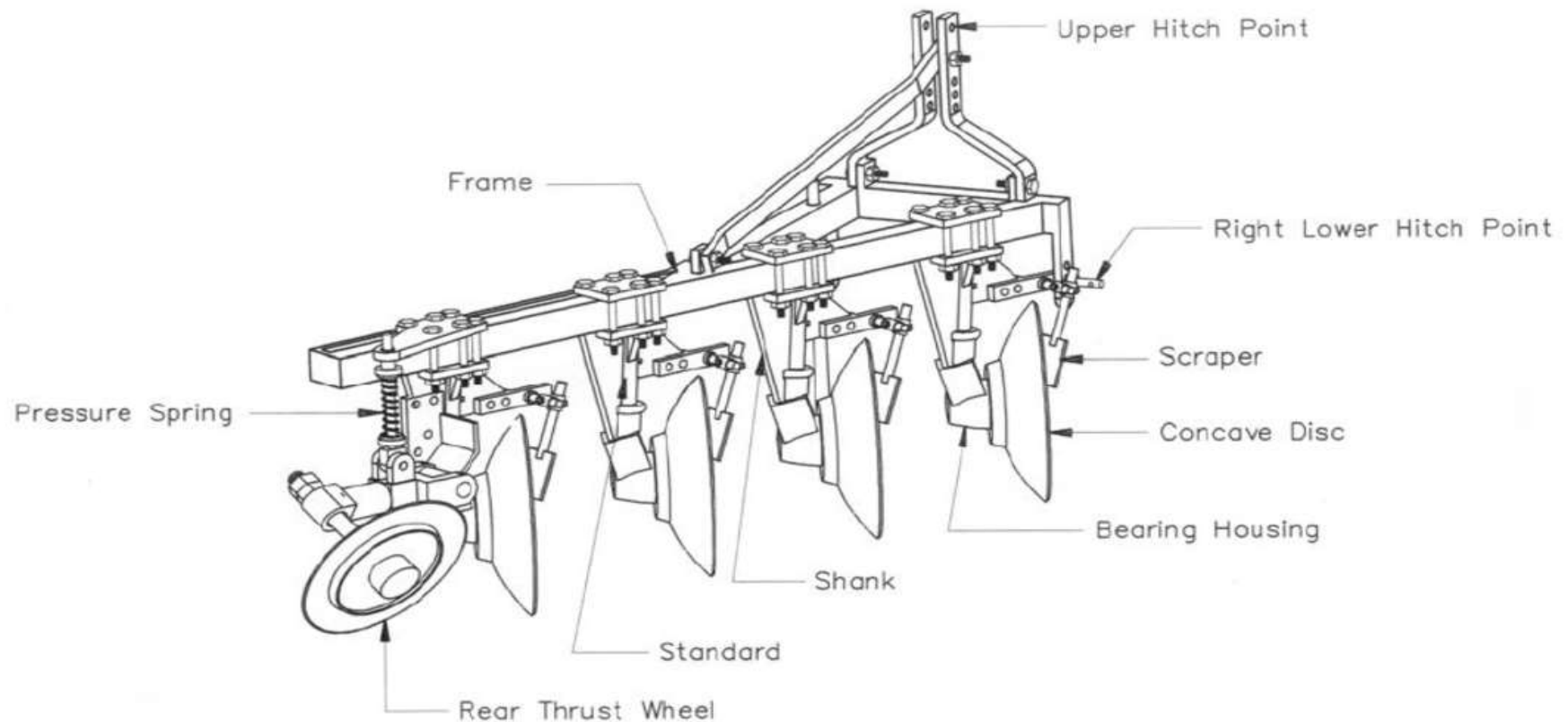

Types of Disc Plow:

Disc plows are divided into two main categories

1) Bullock drawn

a) Sulky type

b) Gang type: attached to universal frame which is mounted on two wheels.

2) According to mounting

a) Mounted

b) Semi-mounted

c) Trailed

3) Tractor drawn

a) Standard disc plow

b) Vertical disc plow or harrow plow or wheat land plow

c) Cylinder plow or disc tiller or tiller disc plow

Sahubai
Single Disc Plough





(i) Standard disc plough

- Steel disc of 60 to 90 cm dia. set at an angle to the direction of travel.
- Each disc revolves on a stub axle in a thrust bearing, carried at the lower end of a strong stand which is bolted to the plough beam.
- Angle of the disc to the vertical and to the furrow wall is adjustable.
In action, the disc cuts the soil, breaks it and pushes it sideways.
- Little inversion of furrow slice and little burying of weeds & trashes.
- Mounted type or trailed type. In mounted disc plough, the side thrust is taken by the wheels of the tractor.

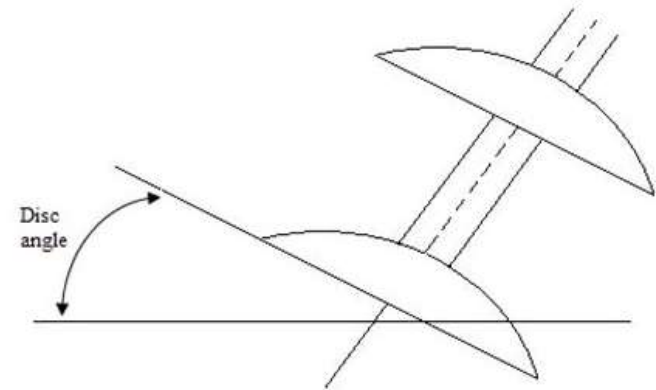
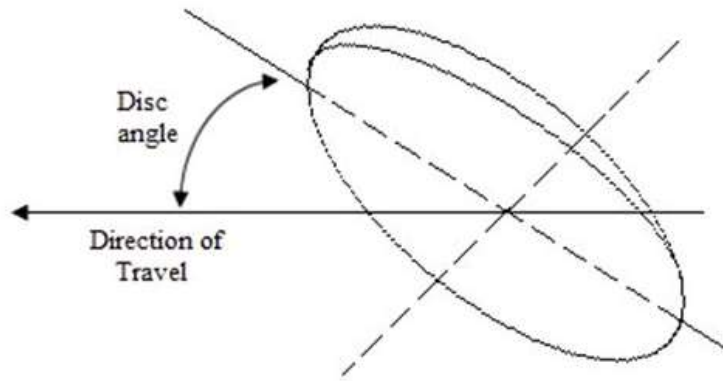

Disc angle - Angle at which the plane of the cutting edge of the disc is inclined to the direction of travel. (between 42° to 45°).

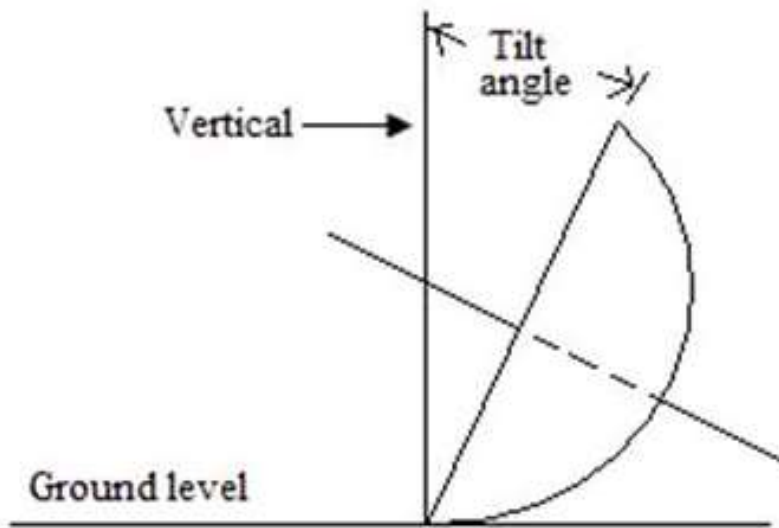

Tilt angle : Angle at which the plane of the cutting edge of the disc is inclined to a vertical line.

Varies from 15° to 25°

DRAFT OF DISC PLOW:

Lighter in draft than MBP, turning same volume of soil in similar conditions. In very hard soil extra weight is added to wheel which increases draft. Bearing & scrapers of disc plow also affect the draft.

Adjustments on disc plow:

- i) Penetration is improved by increasing disc angle.
- ii) Penetration is improved by decreasing tilt angle.
- iii) Penetration is improved by adding additional weight on plow.

Depth of penetration ranges 3” - 15”. For better penetration discs should be sharpened.

Width of Cut:

- Adjusted by adjusting angle between land wheel axle and frame.
- Improved by increasing disc angle and decreasing tilt angle.

To obtain proper degree of pulverization and depth of cut

1. Increase the tilt angle to increase penetration (depth of cut)
2. Increase the disc angle to increase the width of cut. But increasing disc angle will reduce the depth of cut
3. Addition of weights on the plough will increase the penetrations
4. Keep the disc edges sharp.

This will reduce the draft requirement . Adjust the plough wheels properly to keep the plough running level



Parts of Disc Plough:

(1) Disc blade:

- Disc type blades are mounted for cutting of soil.
- No. of blades and dia. determine plough capacity.
- Concavity affects disc angle and soil turning.
- Shallow concavity depends on diameter of discs.
- Depth of cut depends on diameter of discs.
- About 1/3rd of blade dia. is the limit for depth.
- Width of cut depends on diameter of blade.
- Width of cut is normally 0.4 times of dia. of disc blade.

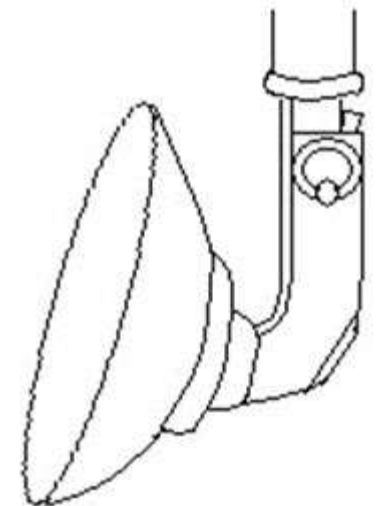
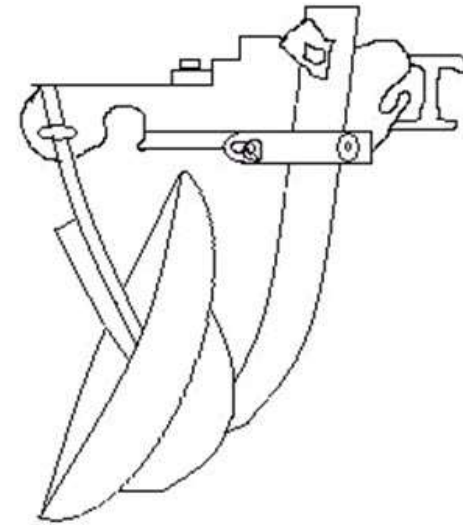

- Disc is made of heat treated steel of 5 mm to 10 mm thickness.
- Amount of concavity varies with the dia.of the disc.
(8 cm for 60 cm dia. disc & 16 cm for 95 cm dia.)

Disc - A circular, concave revolving steel plate used for cutting and inverting the soil.

Scraper - A device to remove soil that tend to stick to the working surface of a disc

Types :

- 1) Disc scraper used in non-scouring soils
- 2) Mould board scraper used to turn over soil and trash
- 3) Hoe scraper used in sticky soils.

Concavity - Depth measured at the centre of the disc by placing its concave side on a flat surface.

2.Standard: Connects disc bearing and plough frame.

Beam is bent for disc attachment for reducing cost.

3. Plough Frame: Standards are attached to the plough frame. It has provision for disc angle adj., adding or removing standard & discs.

(4) **Rear Furrow Wheel:** To stabilize the plough and take side thrust, rear furrow wheel is fixed at end.

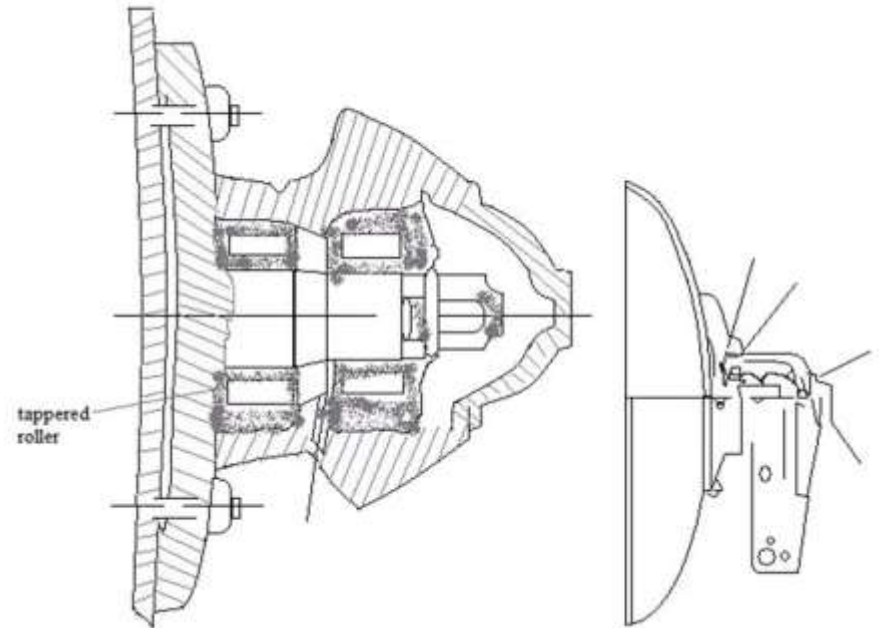
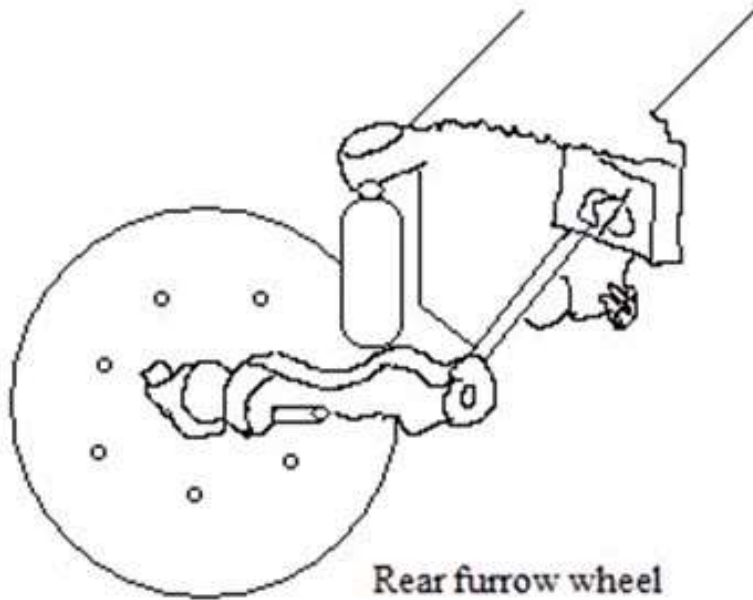

5. Bearings: Disc blades are at an angle to the direction of travel so both **radial & thrust forces** are present.

Radial forces push against an axle at right angle while thrust forces push along the axis. (taper roller bearings are used).



Vertical Disc Plow:

- Also called as one-way disc plow, harrow plow and wheat land plow.
- Discs are uniformly spaced along a common axle or gang bolt and clamped together through spacer spools, entire gang rotates as a unit.
- It is about halfway between the standard disc plow and disc harrow in its soil working action.
- Used in plain areas and where shallow plowing and mixing of stubble with soil is required.
- Dia. of discs varies 51 to 61 cm and spacing from 20 to 25 cm apart along the gang bolt.
- Width of cut per disc depends upon the angle between gang axis and direction of travel.
- Disc angle ranges from 40 to 45 degrees.

S. No.	Comparison	Standard Disc Plough	Vertical Disc Plough
1.	Mounting of disc	Individual axis	Common axis
2.	Number of discs	1-6	5-24
3.	Sizes of discs	60-75 cm	40-60 cm
4.	Spacing	18-30 cm	18-22 cm
5.	Concavity	More	Less
6.	Depth of cut	30-40 cm	8-10 cm
7.	Angle to direction of travel	42-45 degree	35-60 degree
8.	Tilt angle	15-25 degree	0 degree
9.	Weight/disc	200-600 kg	50-100 kg
10.	Draft requirement	High	Low



Advantages over MB Plough:

- Disc plow can be forced to penetrate into soil, which is too hard and dry for working with a MBP
- Works well in sticky soil in which a MBP doesn't scour.
- Useful for deep plowing.
- Used in stony & stumpy soil without much danger of breakage.
- Works well even after a part of disc is worn off in abrasive soil.
- Works in loose soil without much clogging.
- Without scraper it has more mixing action rather than inversion.
- Maintenance cost is low.(No shares to replace or sharpen).

Disadvantages of Disc Plow

- Can't be used at high speed.(cutting action- slow speed is necessary).
- Not suitable for covering surface trash & weeds as effe.as MBP.
- Leaves field rough and cloddy than MBP.
- Heavier than MBP for equal capacities as penetration depends on weight rather than suction.



Reversible disc plough

- Similar to standard disc plough, except that it can turn over the furrow slice to left or right side.
- Having the disc reversible so that the soil can be thrown in the same direction regardless of the direction of travel.
- Improves the rate of work but also leaves the field flat and level.
- Found very successful for contour ploughing because the operation can be performed back and forth on the contour line.
- Soil is turned in the direction required to prevent soil erosion.
- Slopes: gradually leveled by ploughing down the slope every year.

Trouble Shooting

Defect		Reasons		Remedy	
1.	Low Penetration	1.	Blunt disc	1	Sharpen the edge
		2.	Plow too light	2.	Put additional load
		3.	More tilt angle	3	Set tilt angle
2	Heavy draft	1.	Blunt disc	1.	Sharpen the edge
		2.	Furrow too wide	2.	Reduce tilt angle
4.	Less Scouring	1.	Defective Scraper	1.	Adjust the Scraper
5.	Uneven Furrows	1.	Disc angle not uniform	1.	Set disc angle
		2.	Loose bearings	2.	Set bearings
		3.	Hitching defective	3.	Set hitching

Chisel plough

- Used to break through and shatter compacted or impermeable soil layers.
- Deep tillage shatters compacted sub soil layers and aids in better infiltration & storage of rainwater in root zone.
- Improved soil structure also results in better development of root system and the yield of crops and their drought tolerance is also improved.
- **Components:** share, tyne (chisel), beam, cross shaft and top link connection.

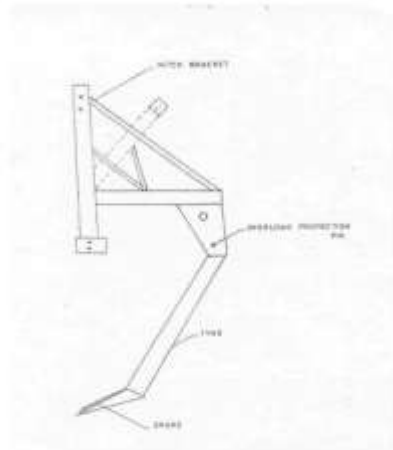

Sub-Soil plough

- To penetrate deeper than the conventional cultivation machinery & break up the layers of the soil, which have become compacted due to the movement of heavy machinery or as a result of continuous ploughing at a constant depth.
- Compacted areas prevent the natural drainage of the soil, inhibit passage of air & nutrients through soil structure.
- Consists heavier tyne than chisel plough to break through impervious layer shattering the sub-soil to a depth of 45 to 75 cm & requires 60 to 100 hp tractor.
- Advantages are same as that of chisel plough.

Benefits of chisel & subsoiler plough :

Chisel ploughing loosen and aerate the soil

Reduces the effect of compaction

Can help break up hardpan

Reduces soil erosion

Prevents formation of surface crusts, which helps water to infiltrate the soil

Chisel ploughing severe weed roots below the surface.



Ploughing of land and Methods of Ploughing

Ploughing System

Normal Ploughing: ploughing up to a depth of about 15 cm.

Contour Ploughing: method of ploughing in which the soil broken and turned along the contours.

Ploughing of Land

➤ Separates the top layer of soil into furrow slices. Furrows are turned sideways & inverted to a varying degree, depending upon the type of plough being used.

- (i) **Furrow:** It is a trench formed by an implement in the soil during the field operation.
- (ii) **Furrow slice:** The mass of soil cut, lifted and thrown to one side .
- (iii) **Furrow wall:** An undisturbed soil surface by the side of a furrow.
- (iv) **Crown:** Top portion of the turned furrow slice is called crown.
- (v) **Back furrow:** A raised ridge left at the centre of the strip of land when ploughing is started from centre to side is called back furrow. When the ploughing is started in the middle of a field, furrow is collected across the field & while returning trip another furrow slice is lapped over the first furrow. Raised ridge is named as back furrow.
- (vi) **Dead furrow:** An open trench left in between two adjacent strips of land after finishing ploughing is called dead furrow

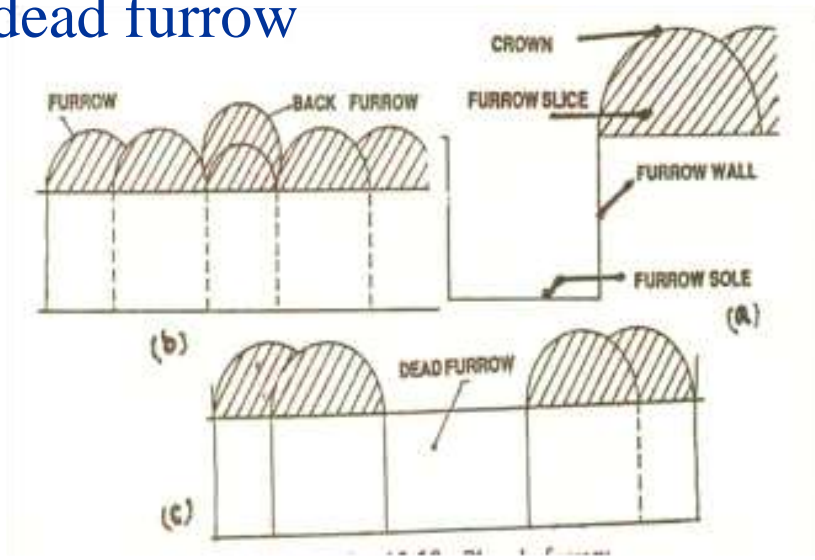
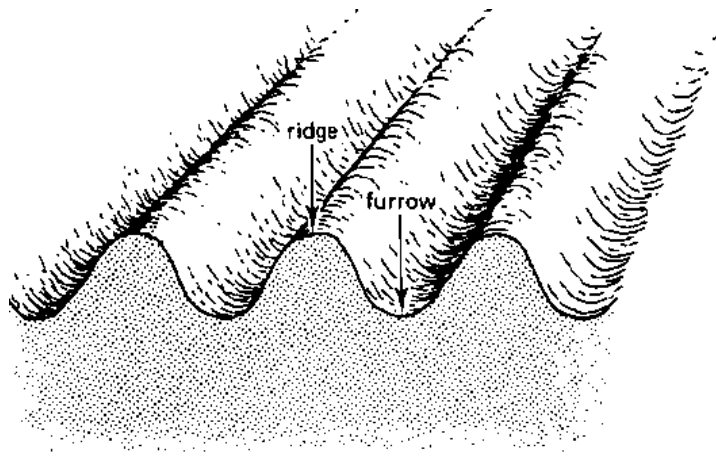



(vii) **Head land:** While ploughing a land with a tractor a strip of unploughed land is left at each end of the field for the tractor to turn.

At the end of each trip, the plough is lifted until the tractor and the plough have turned and are in position to start the return trip.

About 6 meters wide for $\frac{2}{3}$ bottom tractor plough and one meter more for each additional bottom

METHODS OF PLOUGHING

A normal right hand plough must always have an open furrow on the right in which to lay the next furrow slice.

Gathering: Whenever a plough works round a strip of **ploughed** land. Tractor and plough turns to right each time the head land is reached. When land is ploughed, raised ridge is will be left in center.(back furrow)

Casting: Whenever a plough works round a strip of **unploughed** land. Tractor and plough turns to the left each time the head land is reached. When land is ploughed,a wide furrow will be left in center (dead furrow)

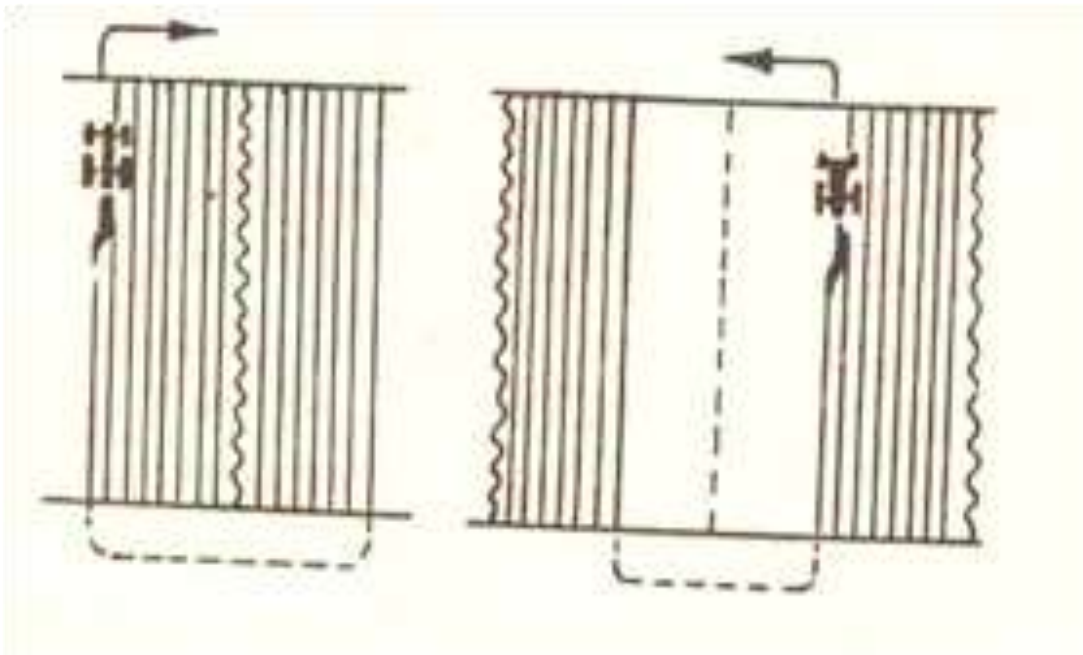

Ploughing of a field either by casting/gathering alone is **uneconomical**. For economical ploughing, **Continuous ploughing method**: Tractor and plough never run idle for more than three quarter land width along headland and never turn in a space narrower than a quarter land width. First the headland is marked and the first ridge is set up at three quarter of a land width from the side (Fig. a).

Operator starts ploughing between first ridge & side land. The operator continues to turn left & cast in the $\frac{3}{4}$ land until ploughing is completed in a $\frac{1}{4}$ land width on each side (Fig. b).

After this ,driver turns right & gathers round $\frac{1}{4}$ land already ploughed . Gathering is continued till un ploughed strip in first $\frac{3}{4}$ land is ploughed & completed. This reduces first full land by a quarter (Fig. c). The remaining $\frac{3}{4}$ land can be treated in same manner as the original $\frac{3}{4}$ land completed earlier.

Repeated for all other lands in the field



b) Round and round ploughing: Plough moves round and round in a field. Adopted under conditions where ridges & furrows interfere with cultivation work. Two ways.

i) Starting at the centre

A small plot of land is marked in the middle of the field and it is ploughed first. After that, the plough works round this small plot and the entire plot is completed. This is not a very economical method.

ii) Starting at the outer end

Tractor starts ploughing at one end of the field and then moves on all the sides of the field and comes gradually from the sides to the centre of the field. Wide diagonals are left unploughed to avoid turning with the plough. There are no back furrows in this method.

c) One way ploughing

Requires use of a reversible/one way plough. turns furrows to the left or right. After the head land has been marked, the operator plough along a straight side land mark. At the end of the first trip, he turns his tractor in a loop and returns down the same furrow. No dead and back furrows are left in the field. In gently sloping fields, this method is suitable.