



SNS COLLEGE OF TECHNOLOGY

(An Autonomous Institution)

COIMBATORE-35

**Accredited by NBA-AICTE and Accredited by NAAC – UGC with A+ Grade
Approved by AICTE, New Delhi & Affiliated to Anna University, Chennai**

DEPARTMENT OF ELECTRICAL AND ELECTRONICS ENGINEERING

COURSE NAME: 16GE301 Professional Ethics

III YEAR / V SEMESTER

Unit 3– Engineering Responsibility for Safety

Topic 1: Three Mile Island





What We'll Discuss

TOPIC OUTLINE



Introduction
Time line events
Health Effects
Recommendation



Location



Three Mile Island Nuclear Generating Station sits on an island of area of 3.29 km² (814 acres) in the Susquehanna River Pennsylvania, near Harrisburg.





Location





Introduction



- March 28, 1979 – 4 AM
- Minor malfunction caused the second reactor to shut down almost immediately
- A relief valve was supposed to close, but it did not, contrary to what the instrumentation showed
- Operators struggled to determine the problem and an appropriate solution
- After almost 16 hours and the collaboration of 60 or more people, the situation was under control



Introduction

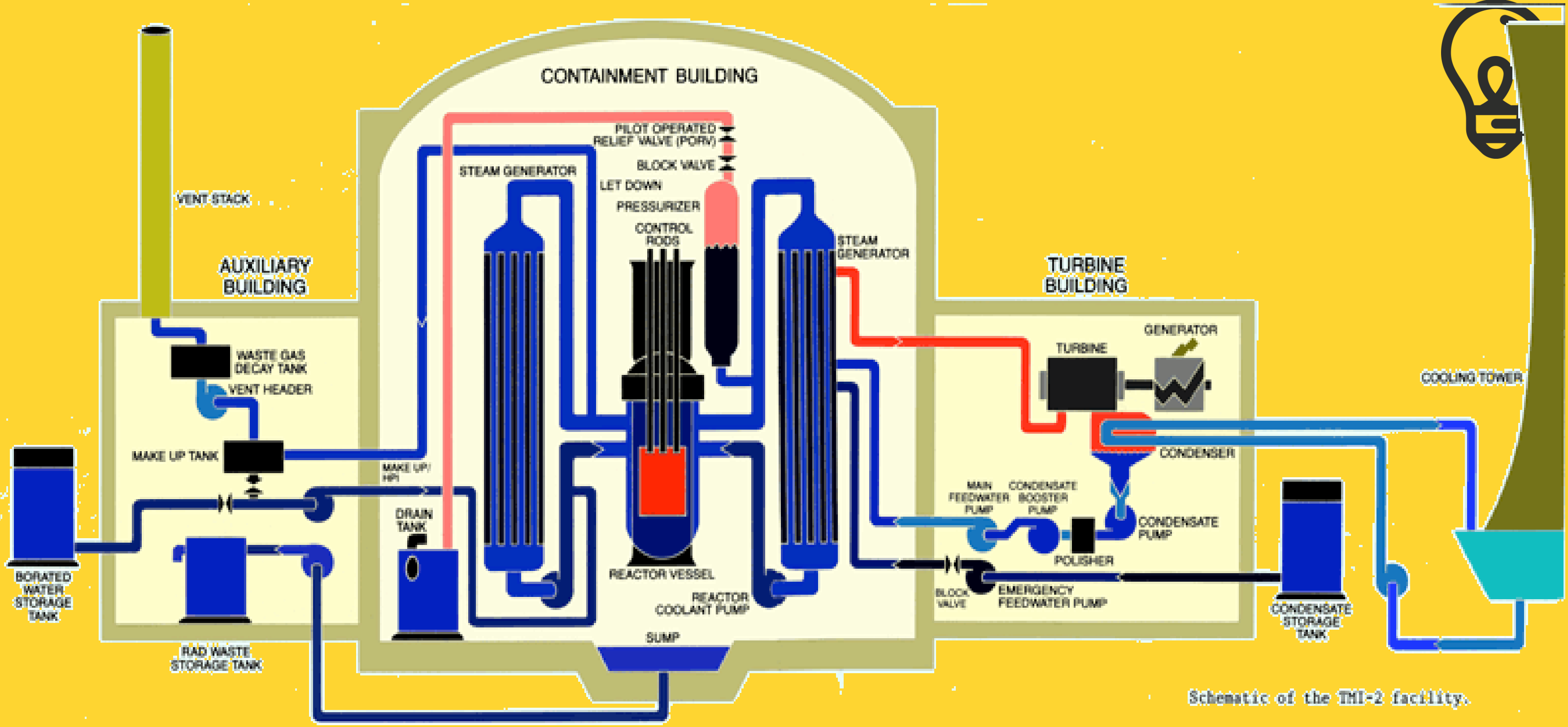

Schematic of the TH1-2 facility.



Timeline of Events



- 0:00:00 A maintenance problem causes the feedwater pumps to shut down.
- 0:00:01 An alarm sounds in the control room.
- 0:00:03 Pressure relief valve (PORV) opens automatically.
- 0:00:04 Backup pumps in the secondary loop come on. However, the pumps are disconnected from the system because of a maintenance error two days before.

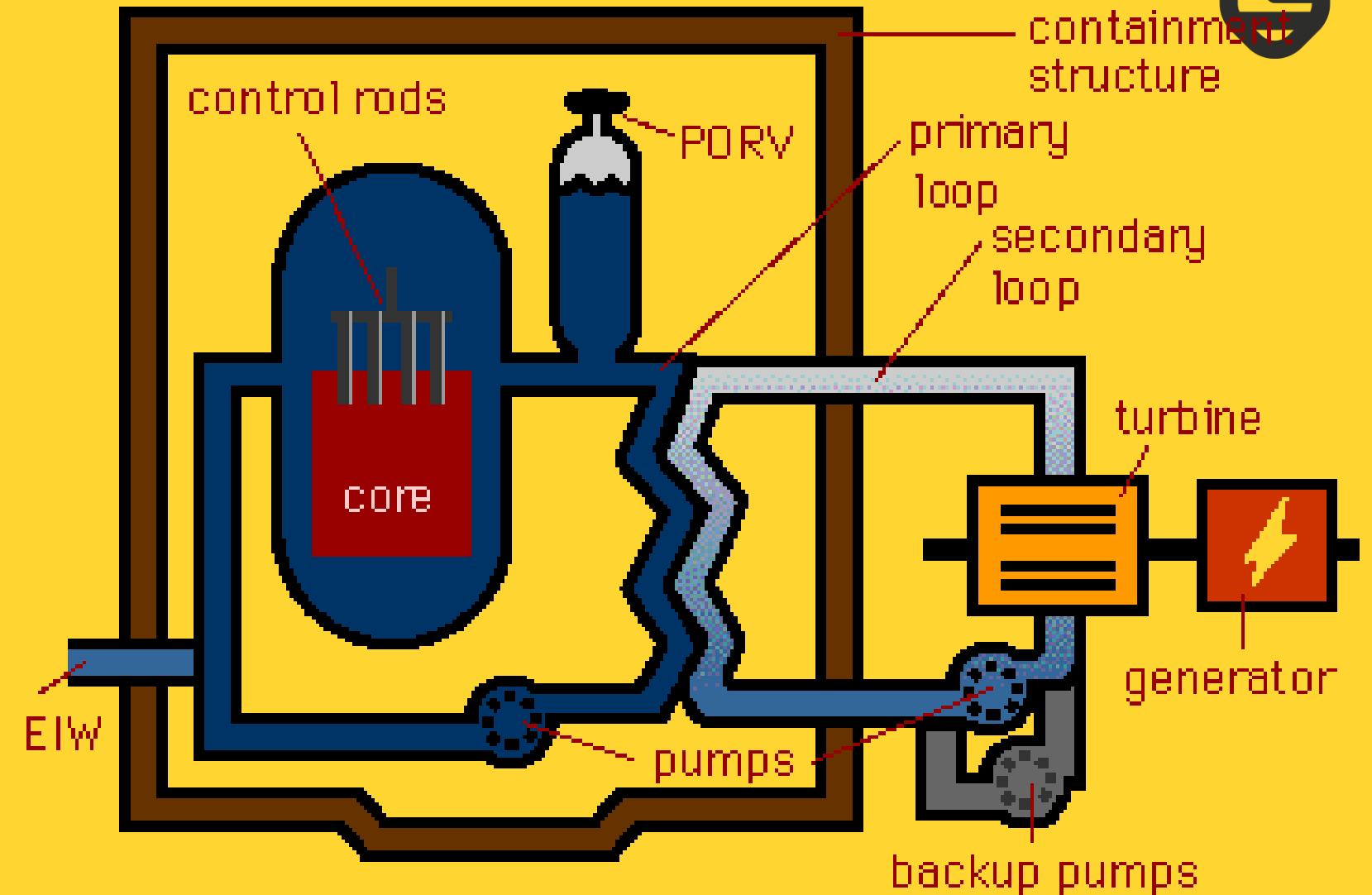



Timeline of Events

0:00:09 The PORV light goes out indicating that the valve had closed. However, the valve is still open. This led to a LOCA (Loss of Coolant Accident).



Confirmation Bias/Incorrect Mental Model

0:02:00 EIW (Emergency injection water) comes on, allowing water to flow into primary loop. This is a normal safety feature in the event of a LOCA.

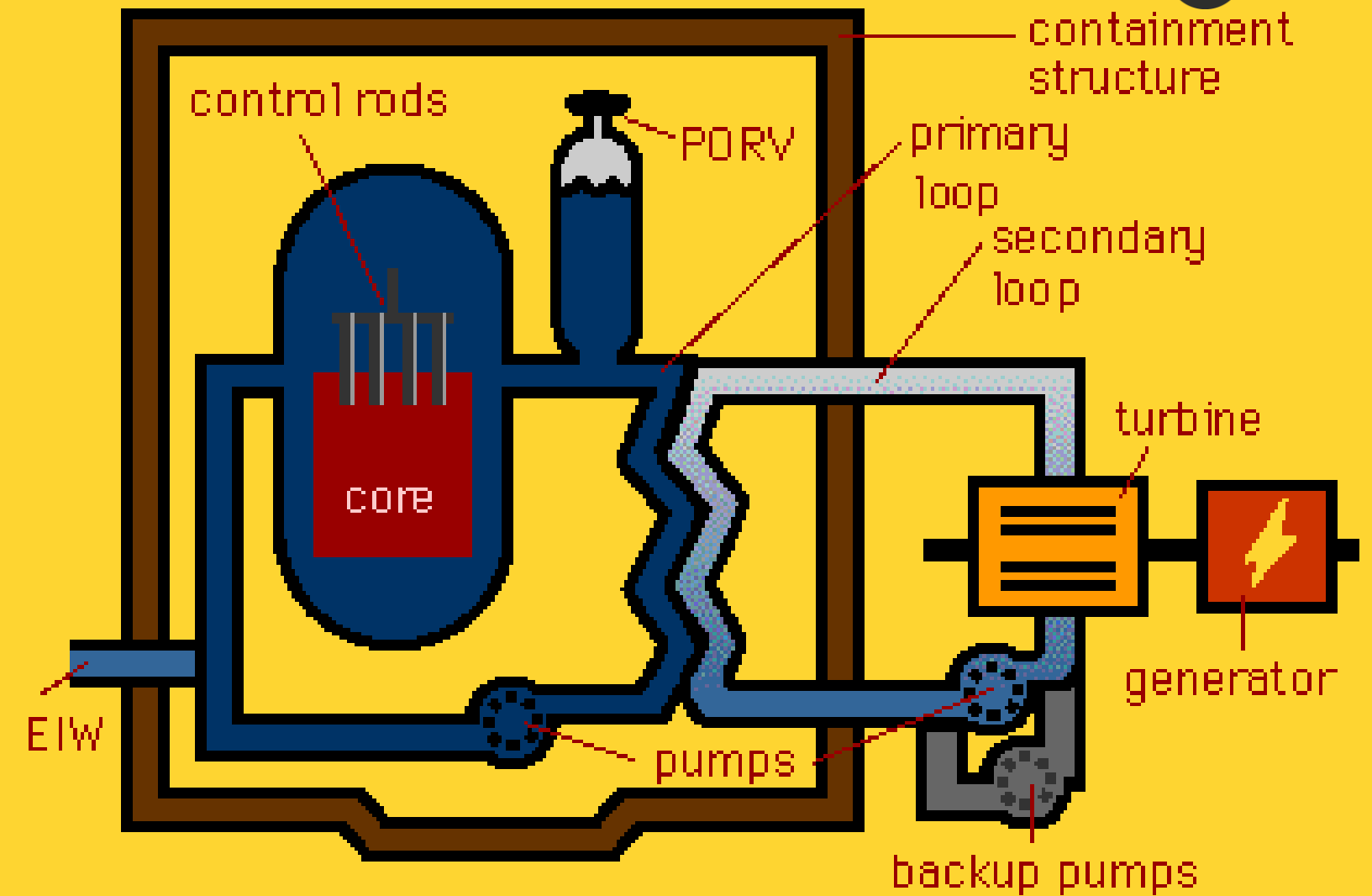



Timeline of Events

0:04:30 Operators turn off the EIW because the water level is rising and the pressure is dropping.

Confirmation Bias

0:08:00 An operator finally notices that the valves for the backup pumps are closed. He opens them.

0:15:00 3,000 gallons have escaped from the primary loop.

Hick-Hyman Law

0:45:00 Water level in primary loop still dropping.

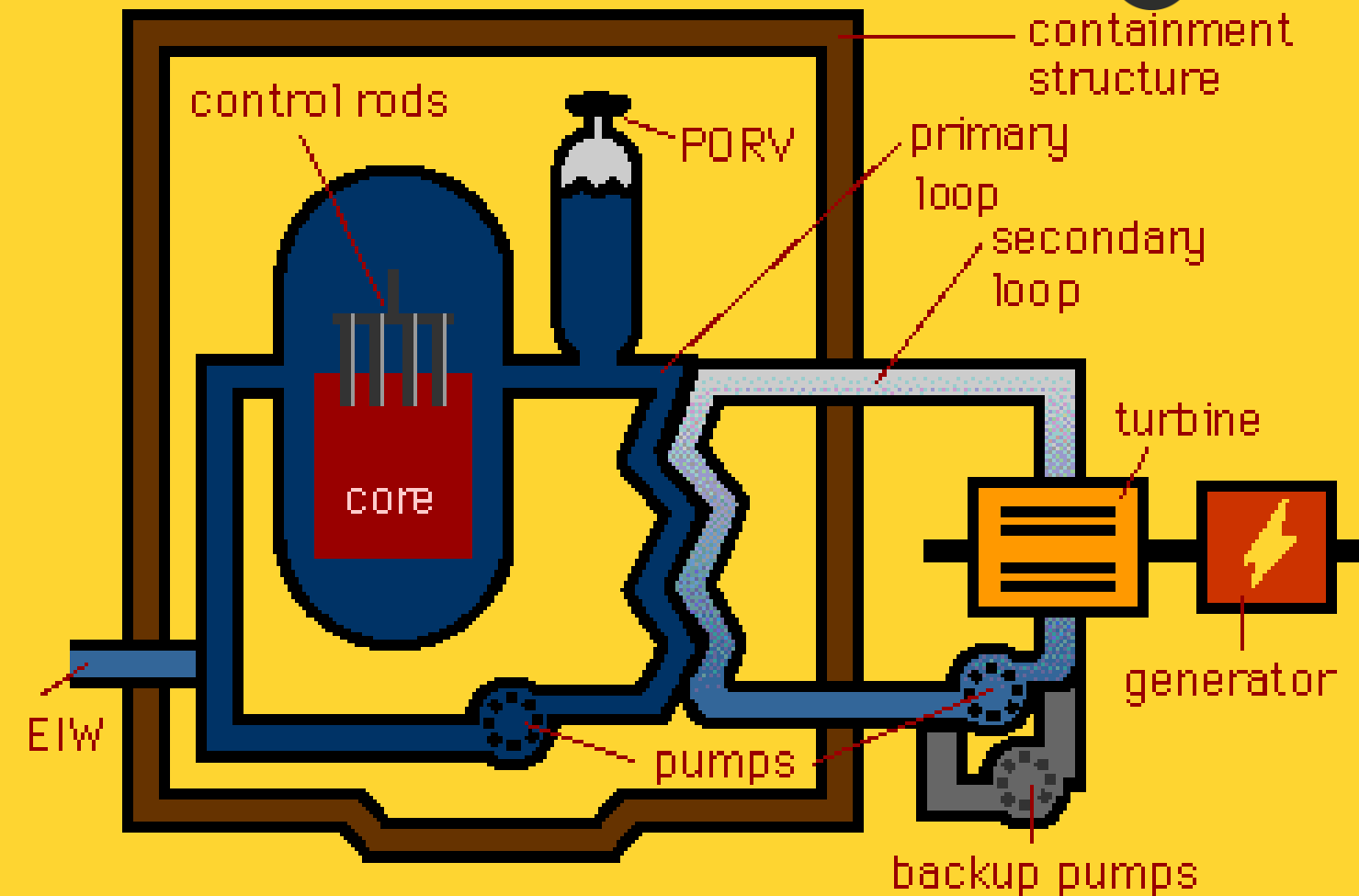



Timeline of Events



- 1:20:00 Pumps pushing water through the primary loop shake violently. 2 of 4 are turned off.
- 1:40:00 The other 2 pumps turn off.
- 2:15:00 Water no longer covers the top of the core. Control rods release hydrogen and radioactive gases through the PORV.

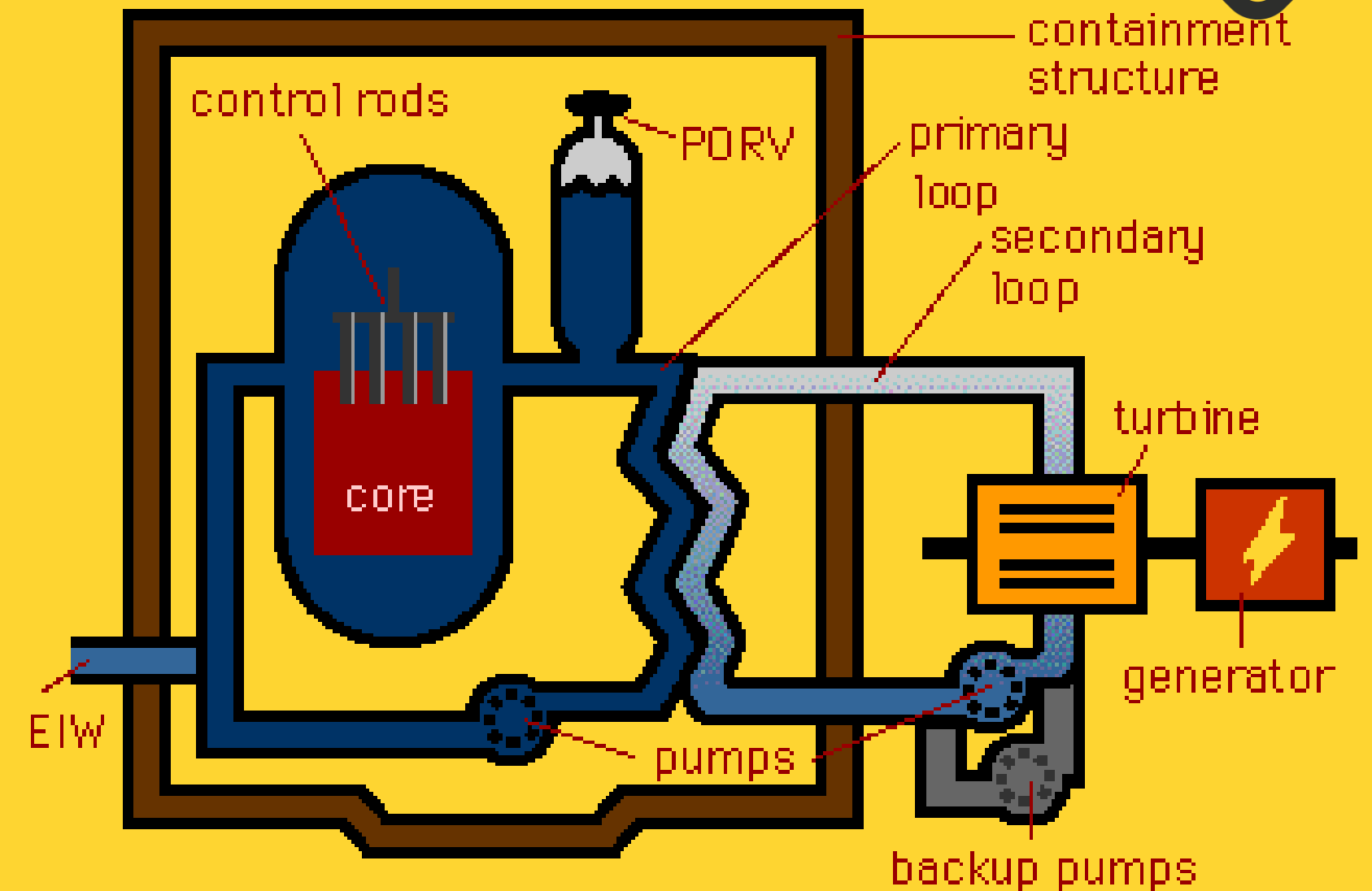



Time line of Events



2:20:00 An operator from the next shift comes on duty. He notices that the PORV discharge temperature is abnormally high. He shuts the PORV's backup valve.

2:30:00 Operators receive first indication that radioactivity levels are going up.

2:45:00 The radiation alarm sounds.

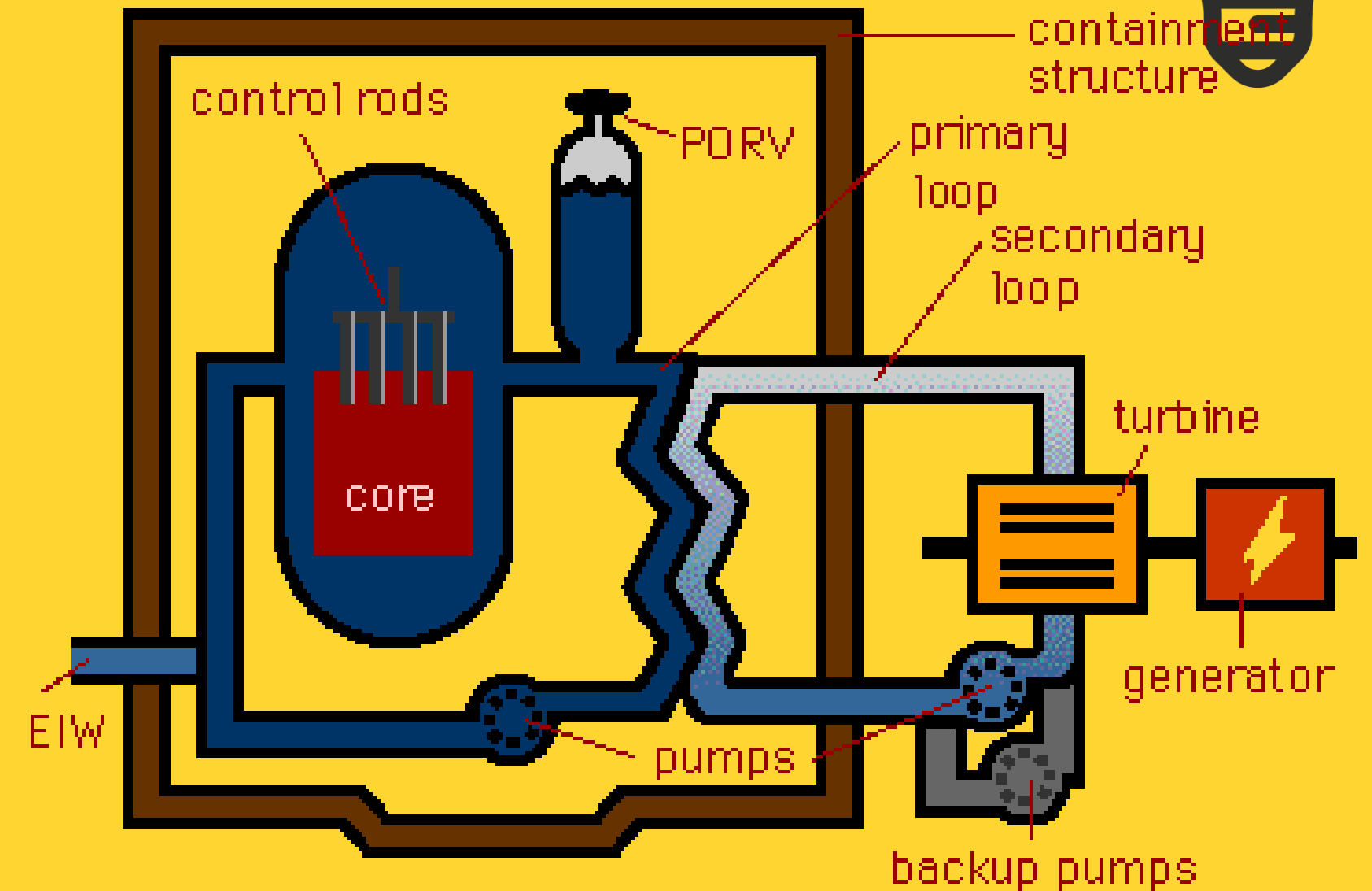



Time line of Events



3:00:00 High temperatures in the core lead some to believe that the core is uncovered. The temperature is reading off of the scale which leads others to believe that the reading is wrong. Overconfidence

3:40:00 EIW is turned back on.

6:27:00 All non-essential personnel are evacuated.

7.30:00 PORV backup valve is opened to lower the pressure in the primary loop.

15.50:00 The pumps in the primary loop are turned back on.

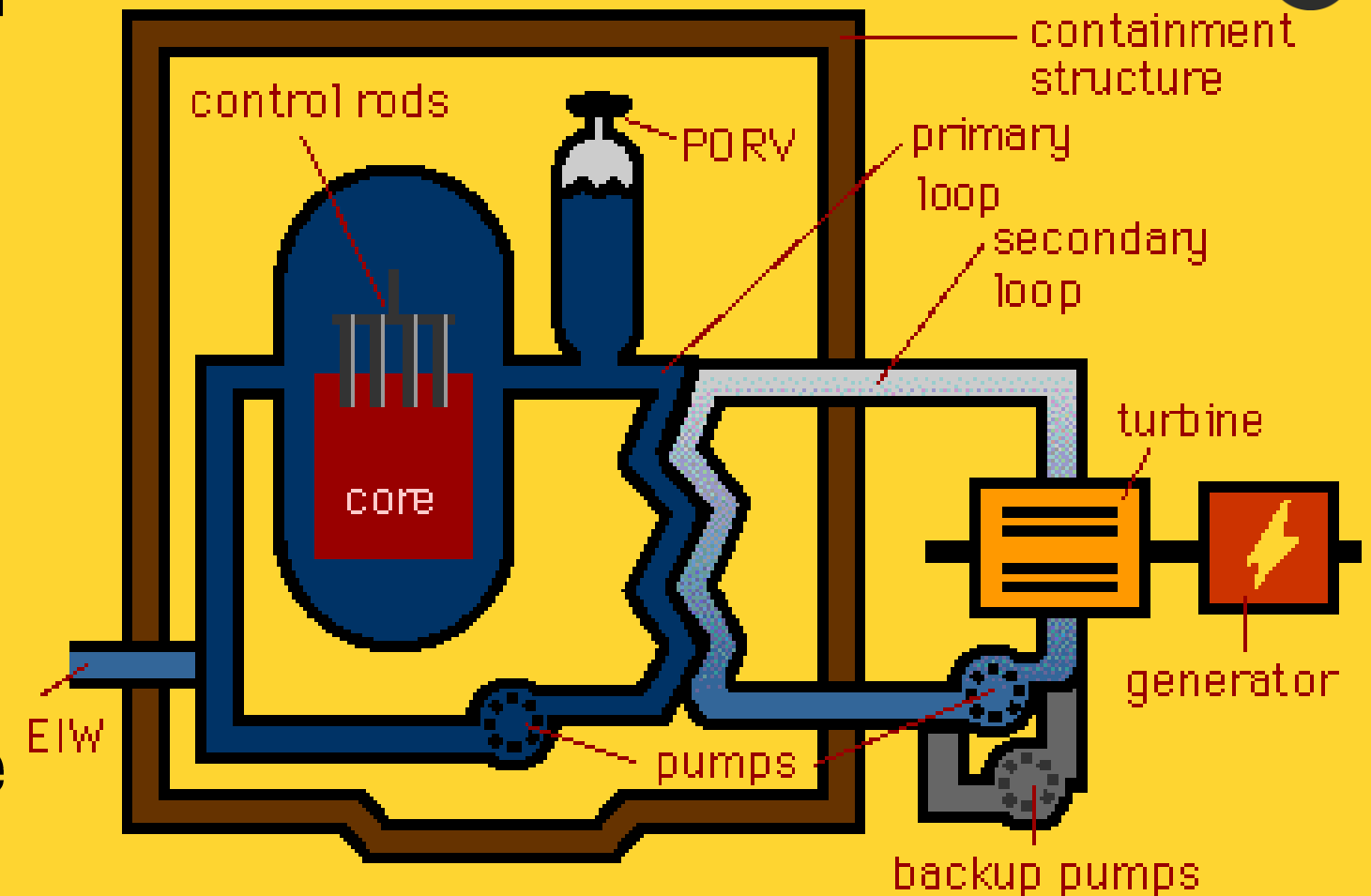



Amount of contamination



- Hydrogen & some radioactive gases were released into atmosphere.
- A maximum of 13 million Curie of radioactive gases release.
- The maximum dosage to a person at the site boundary have been less than 100 mrem



Health Effects



- Government claimed no injuries or adverse health effects from accidents.
- Only one additional cancer death from radiation absorbed following the accident would result to those living within 50 miles of the plant.
- Studies found
 - An increase in infant death.
 - An increase in babies born with hypothyroidism
 - By late 1990, there had been no peer-reviewed articles that present any data on rates of cancer or other diseases.



Iodine - 131



- Radiation form of iodine.
- Affects thyroid gland.
- Children have much smaller thyroid gland.
- More energy per gram = higher dose.
- Milk is the main route of contamination.



Recommendations



- Use human factors principles to design the control panels.
- Better training program for operators.
- Better indicators for status of valves.
- Shift of plant priorities from continuing power production to safety.



RECALL TIME

**ASSESSMENT
TIME**



THANK YOU