



SNS COLLEGE OF TECHNOLOGY



CNC EDM (Electrical Discharge Machining)

19MEB303 CAD/CAM & AUTOMATION



V.KARTHIK
AP/MECH



Electric Discharge Machining – EDM



- Sometimes it is referred to as **spark machining, spark eroding, burning, die sinking or wire erosion**
- Its a manufacturing process whereby a desired shape is obtained using electrical discharges (sparks)
- Material is removed from the work piece by a series of rapidly recurring current discharges between two electrodes, separated by a dielectric liquid and subject to an electric voltage
- One of the electrodes – ‘tool-electrode’ or ‘tool’ or ‘electrode’



Electric Discharge Machining – EDM

- Other electrode - workpiece-electrode or ‘workpiece’
- As distance between the two electrodes is reduced, the current intensity becomes greater than the strength of the dielectric (at least in some points) causing it to break

EDM - System

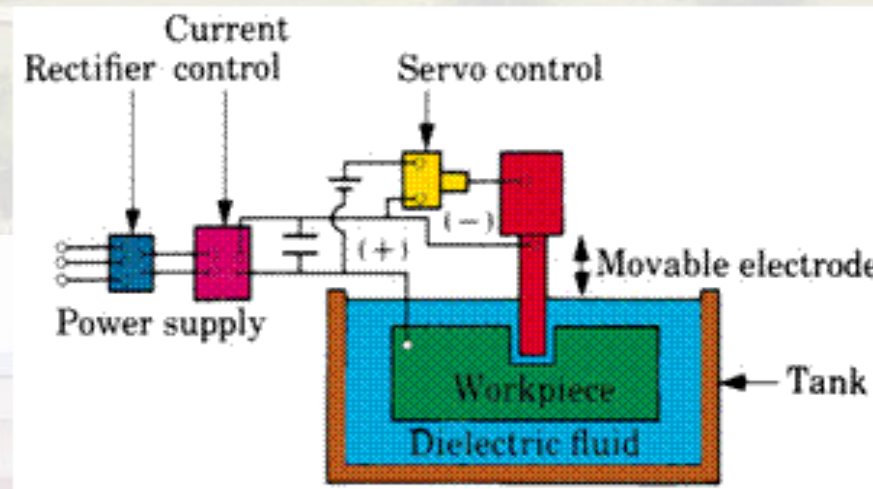

<https://tinyurl.com/yamws5xv>



EDM - Components

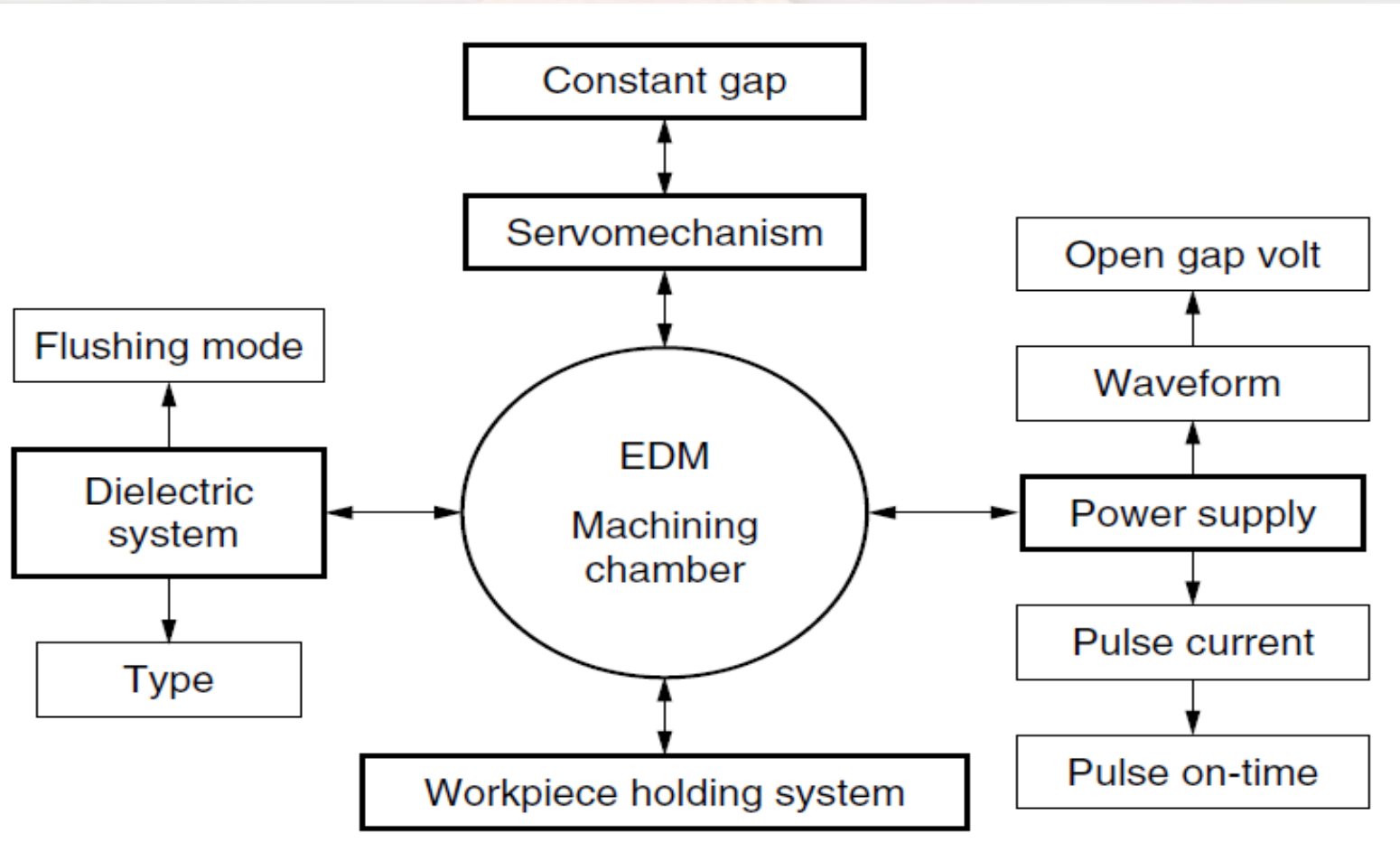

<https://tinyurl.com/y7z6rs46>



EDM - Components



➤ The main components in EDM

- Electric power supply
- Dielectric medium
- Work piece & tool
- Servo control unit.

➤ The work piece and tool are electrically connected to a DC power supply



EDM – Working Principle

- It is a process of metal removal based on the principle of material removal by an interrupted electric spark discharge between the electrode tool and the work piece
- In EDM, a potential difference is applied between the tool and workpiece
- Essential - Both **tool and work material** are to be **conductors**
- The tool and work material are immersed in a dielectric medium
- Generally **kerosene or deionised water** is used as the **dielectric medium**
- A gap is maintained between the tool and the workpiece



EDM – Working Principle

- Depending upon the applied potential difference (50 to 450 V) and the gap between the tool and workpiece, an electric field would be established
- Generally the **tool** is connected to the negative terminal (**cathode**) of the generator and the **workpiece** is connected to positive terminal (**anode**)

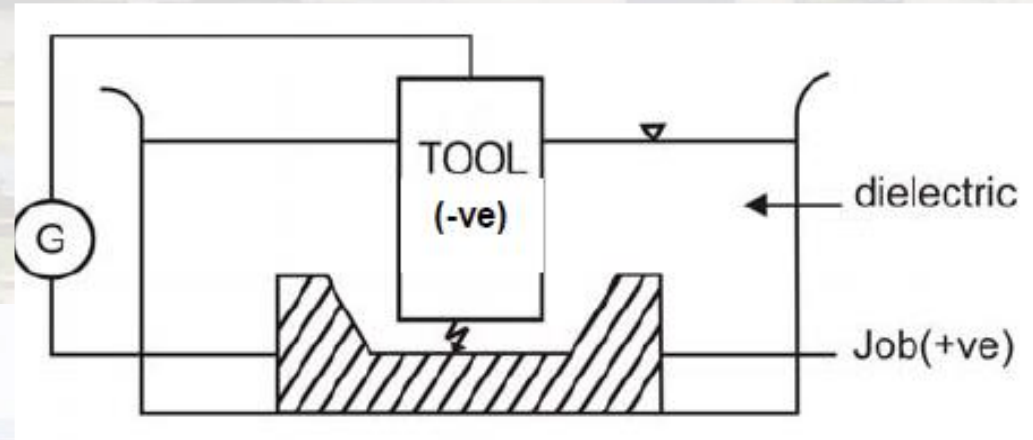
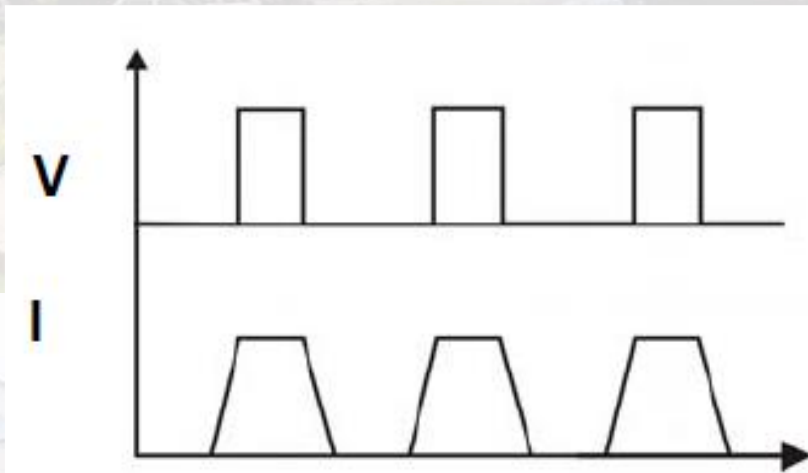

<https://tinyurl.com/y7z6rs46>



EDM – Working Principle

- Upon **withdrawal of potential difference**, plasma channel collapses
- This ultimately **creates compression shock waves** on both the electrode surface
- Particularly at **high spots on work piece surface**, which are closest to the tool
- This **evacuates molten material** and **forms a crater** around the site of the spark
- The whole sequence of operation occurs within a **few microseconds**



EDM – Schematic

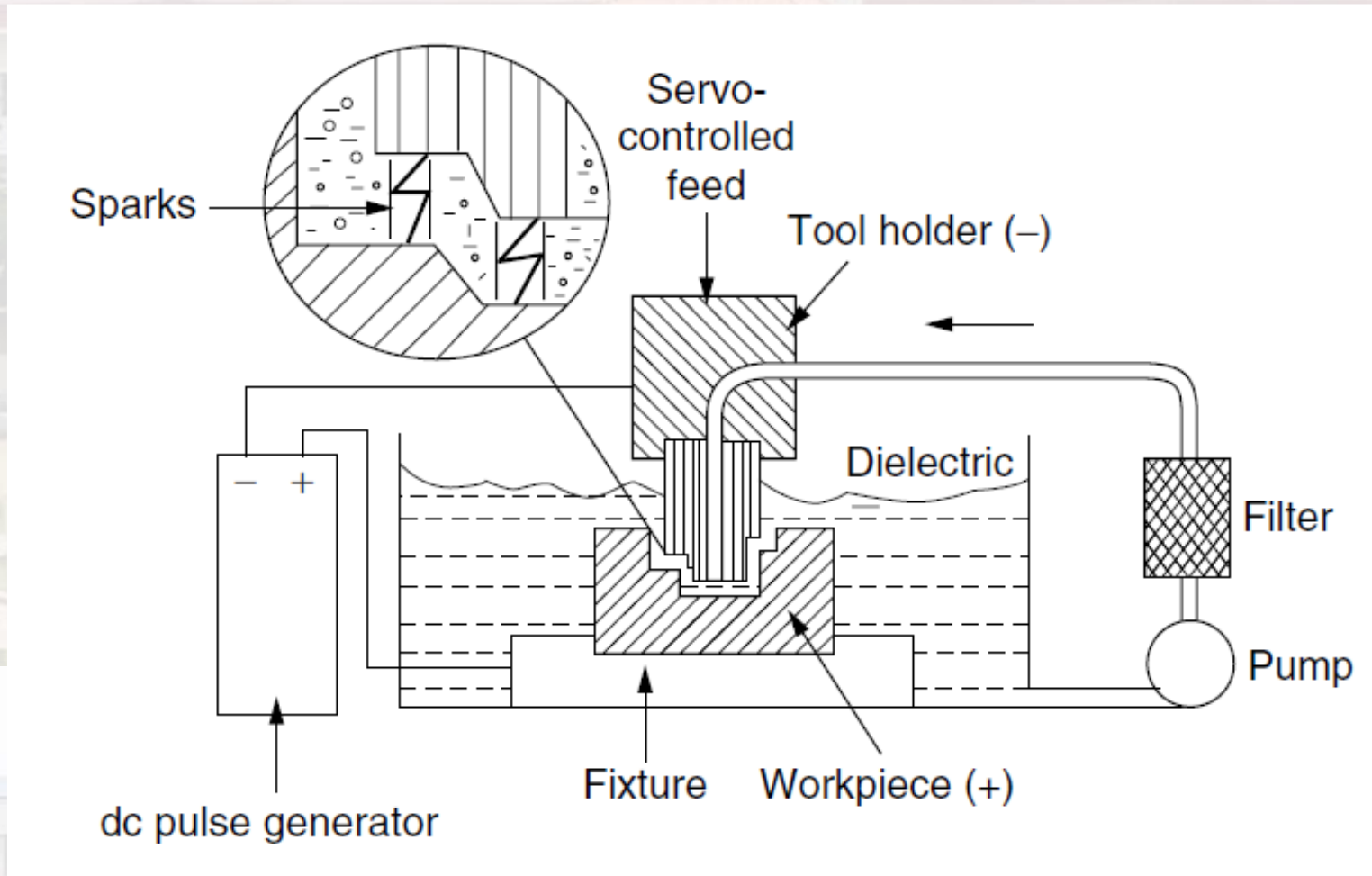

<https://tinyurl.com/y7z6rs46>



EDM – Working Principle

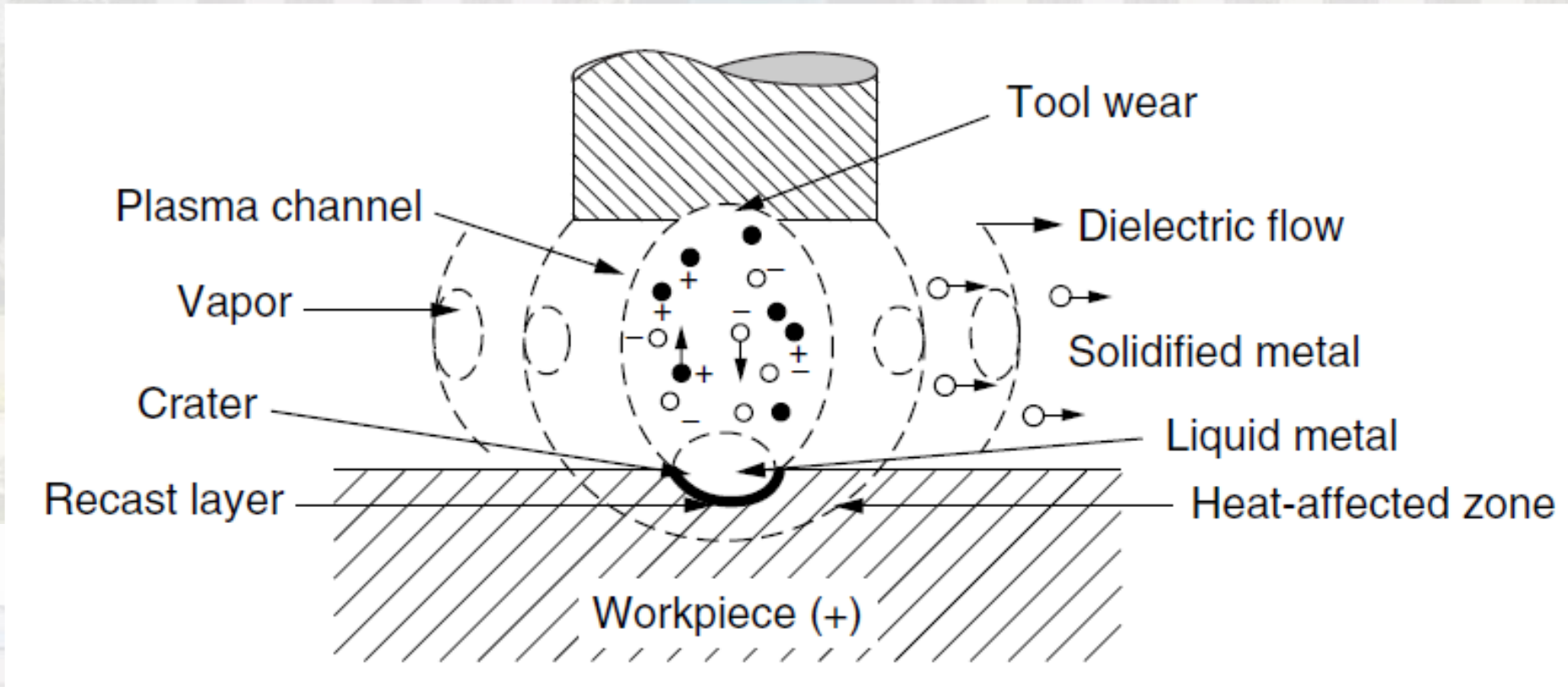

<https://tinyurl.com/y7z6rs46>



EDM – Material Removal Rate

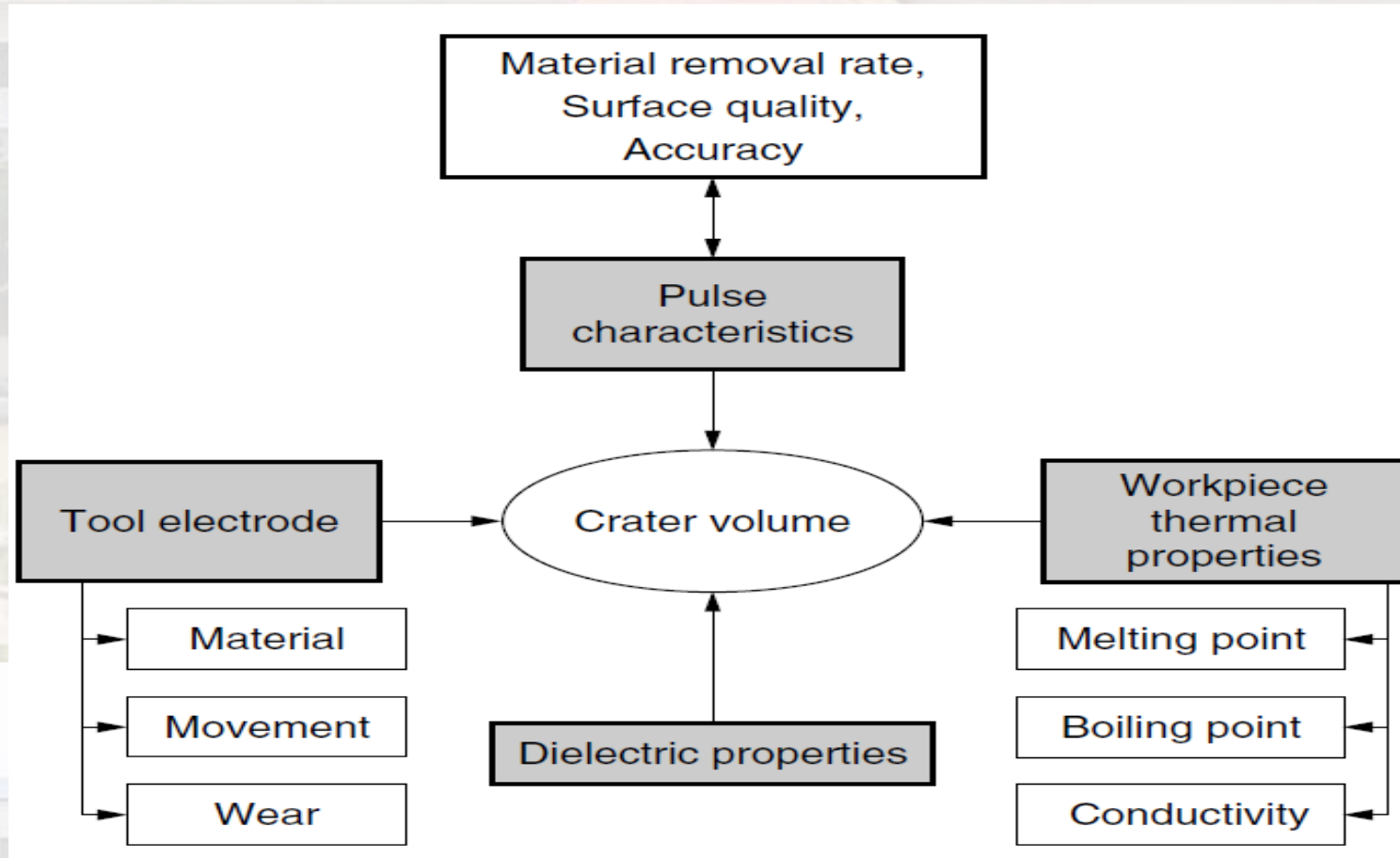

Parameters affecting EDM performance.

<https://tinyurl.com/y7z6rs46>



Applications



- Drilling of micro-holes, thread cutting, helical profile milling, rotary forming, and curved hole drilling
- Delicate work piece like copper parts can be produced by EDM
- Can be applied to all electrically conducting metals and alloys irrespective of their melting points, hardness, toughness, or brittleness
- Other applications: deep, small-dia holes using tungsten wire as tool, narrow slots, cooling holes in super alloy turbine blades, and various intricate shapes
- EDM can be economically employed for extremely hardened work piece



Assessment Questions

1. Which of the following shapes can be produced using Electro discharge machining?
a) **Complex shapes** b) Simple shapes
c) All of the mentioned
2. State whether following statement is true or false regarding the applications of EDM.
“In advanced machining processes, the incorporation of EDM with CIM increased the length of time for unit operation.”
a) True b) **False**
3. What are the values of general feed rates used for drilling in EDM?
a) **0.1 mm/min** b) 0.3 m/min
c) 0.5 mm/min d) 0.7 mm/min



Assessment Questions



4. Which type of electrode is used for drilling in Electro discharge machining?
- a) Flat electrode
 - b) Cuboidal electrode
 - c) **Tubular electrode**
 - d) Spherical electrode
5. When compared to the conventional abrasive sawing, how many times faster is the MRR?
- a) **Twice**
 - b) Thrice
 - c) Four
 - d) Five
6. Which of the following are the applications of Electro discharge machining?
- a) Holes
 - b) Slots
 - c) Texturing
 - d) **All of the mentioned**



SNS COLLEGE OF TECHNOLOGY

THANK YOU