

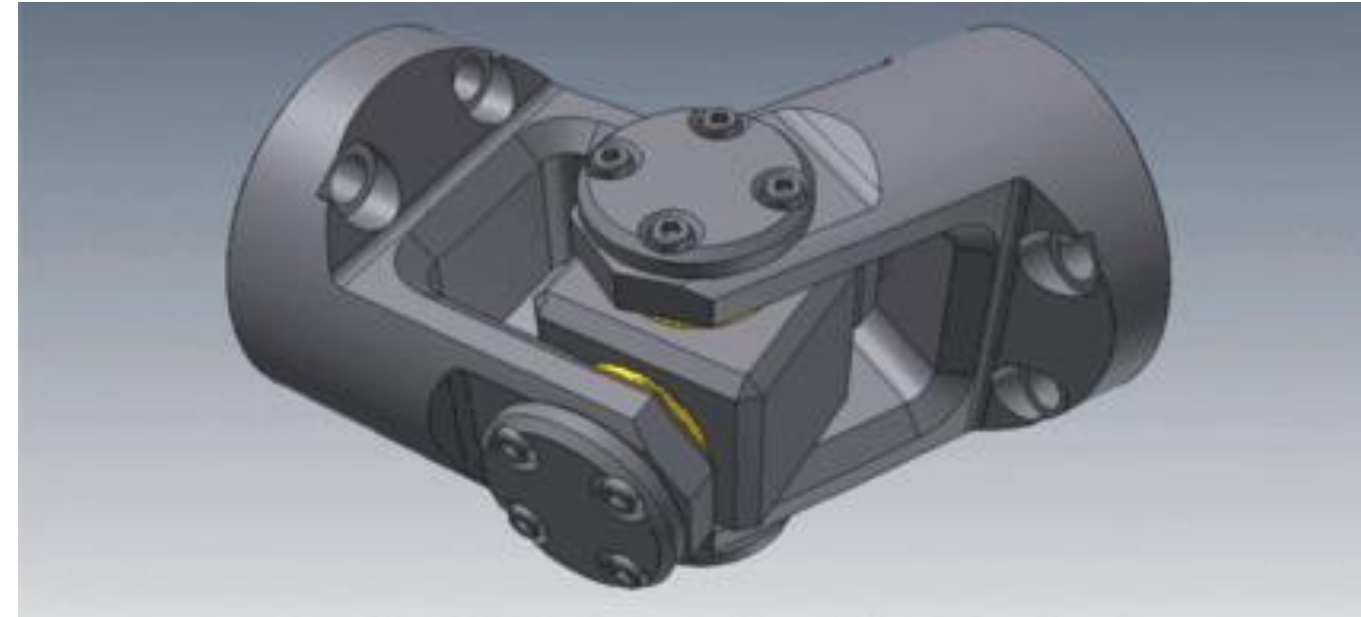

Rotational joint

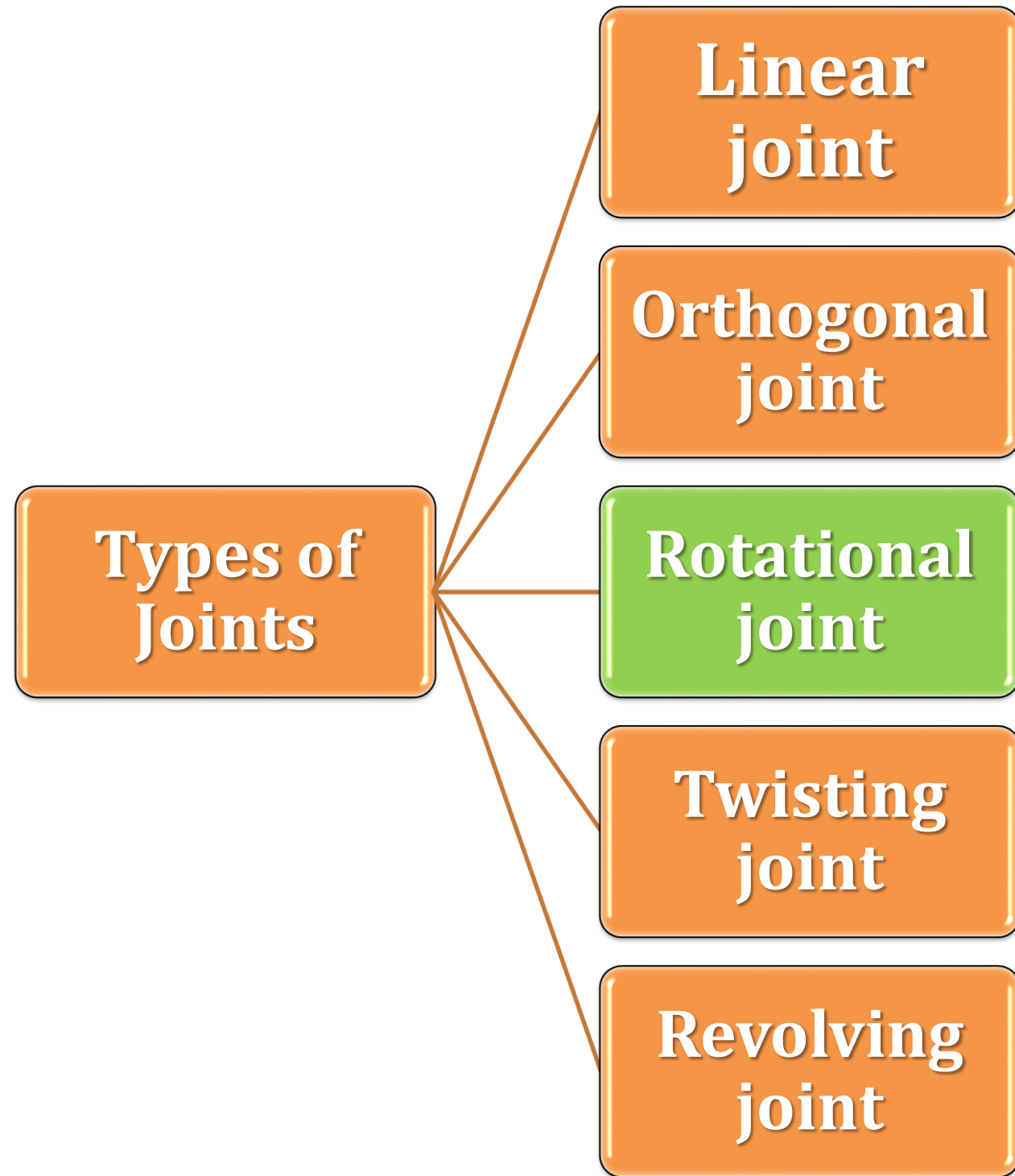

- Type R joint;
- This provides rotational relative motion, with the axis of rotation perpendicular to the axes of the input and output links.

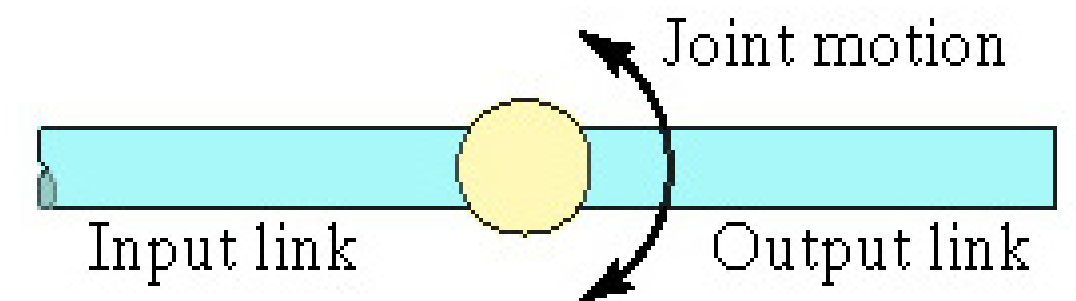



Twisting joint

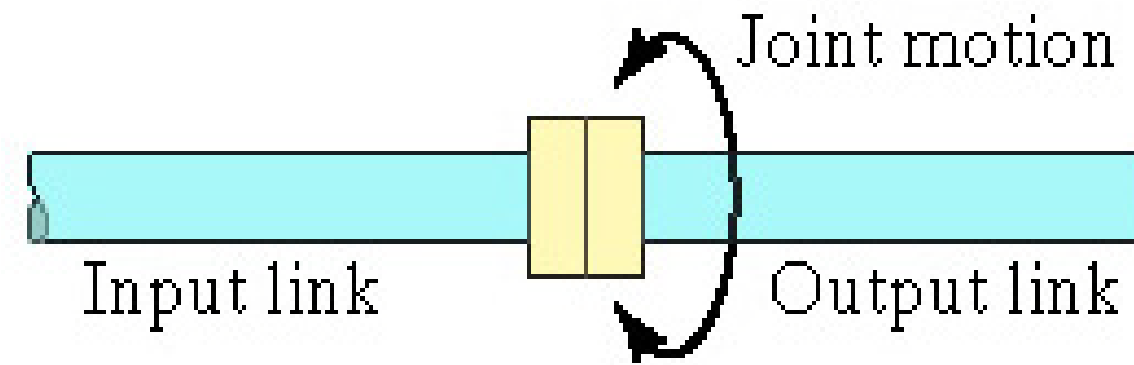
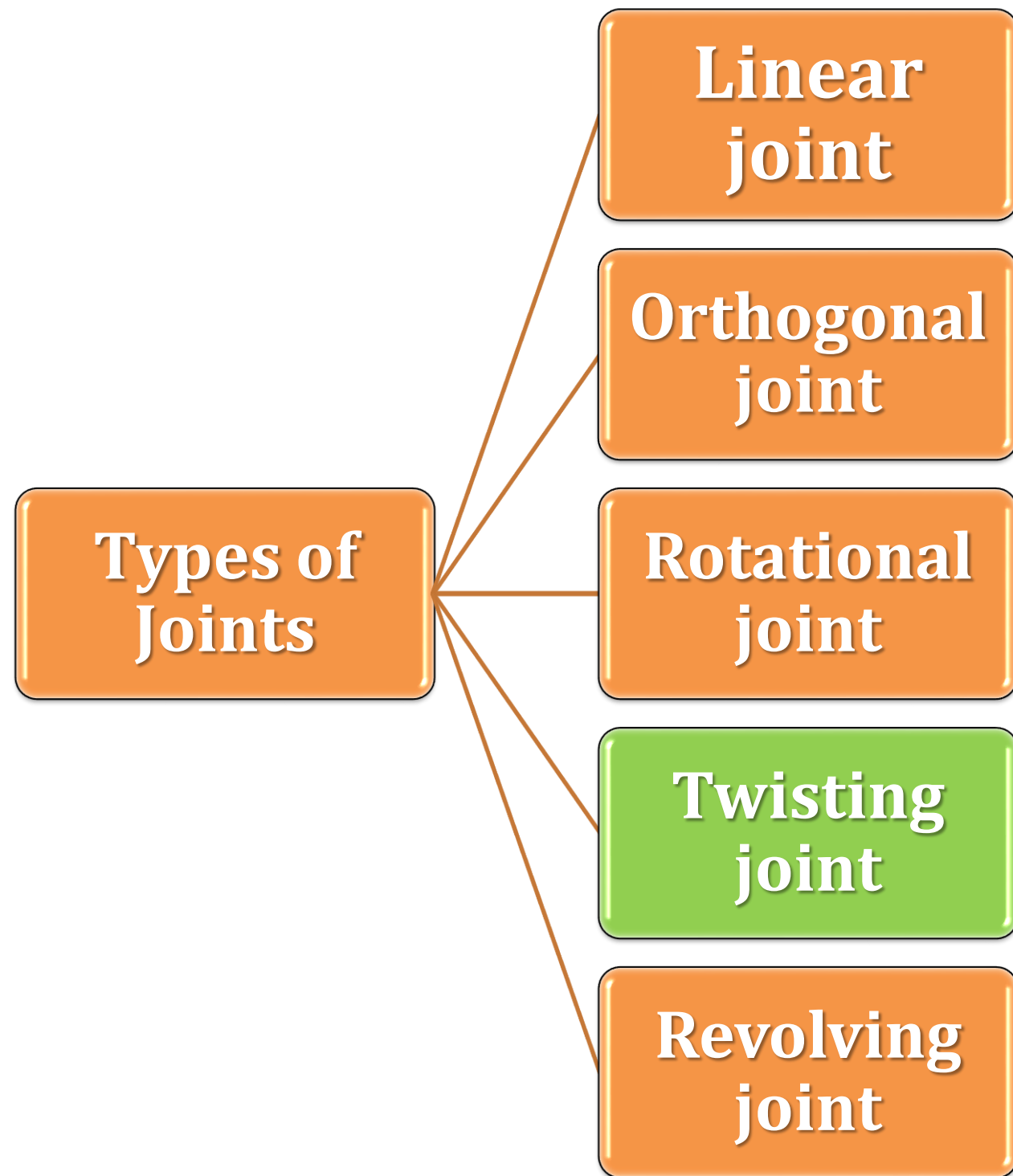

- Type T joint;
- This provides rotary motion, but the axis of rotation is parallel to the axes of the two links.

