



SNS COLLEGE OF TECHNOLOGY



UNIT II -SHEAR FORCE AND BENDING MOMENT

Types of beams: Supports and Loads



EXAMPLE 13.1. Draw shear force and bending moment diagrams for a cantilever beam of span 1.5 m carrying point loads as shown in Fig. 13.3 (a).

SOLUTION. Given : Span (l) = 1.5 m ; Point load at B (W_1) = 1.5 kN and point load at C (W_2) = 2 kN.

Shear force diagram

The shear force diagram is shown in Fig. 13.3 (b) and the values are tabulated here:

$$F_B = -W_1 = -1.5 \text{ kN}$$

$$F_C = -(1.5 + W_2) = -(1.5 + 2) = -3.5 \text{ kN}$$

$$F_A = -3.5 \text{ kN}$$

Bending moment diagram

The bending moment diagram is shown in Fig. 13.3 (c) and the values are tabulated here:

$$M_B = 0$$

$$M_C = -[1.5 \times 0.5] = -0.75 \text{ kN-m}$$

$$M_A = -[(1.5 \times 1.5) + (2 \times 1)] = -4.25 \text{ kN-m}$$

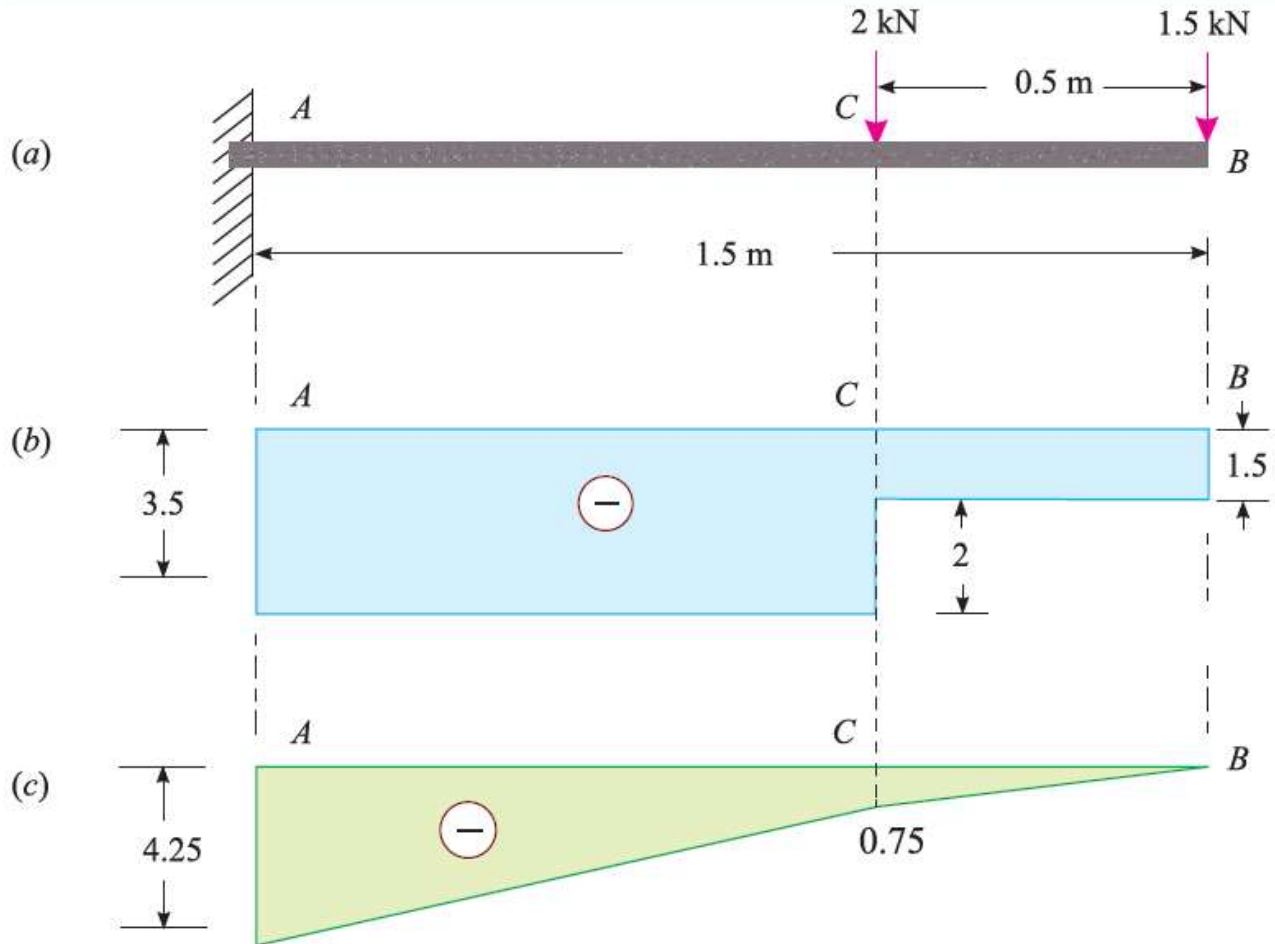

Fig. 13.3



EXAMPLE 13.2. A cantilever beam AB, 2 m long carries a uniformly distributed load of 1.5 kN/m over a length of 1.6 m from the free end. Draw shear force and bending moment diagrams for the beam.

SOLUTION. Given : span (l) = 2 m ; Uniformly distributed load (w) = 1.5 kN/m and length of the cantilever CB carrying load (a) = 1.6 m.

Shear force diagram

The shear force diagram is shown in Fig. 13.5 (b) and the values are tabulated here:

$$F_B = 0$$

$$F_C = -w \cdot a = -1.5 \times 1.6 = -2.4 \text{ kN}$$

$$F_A = -2.4 \text{ kN}$$

Bending moment diagram

The bending moment diagram is shown in Fig. 13.5 (c) and the values are tabulated here:

$$M_B = 0$$

$$M_C = -\frac{wa^2}{2} = \frac{1.5 \times (1.6)^2}{2} = -1.92 \text{ kN-m}$$

$$M_A = -\left[(1.5 \times 1.6) \left(0.4 + \frac{1.6}{2} \right) \right] = -2.88 \text{ kN-m}$$

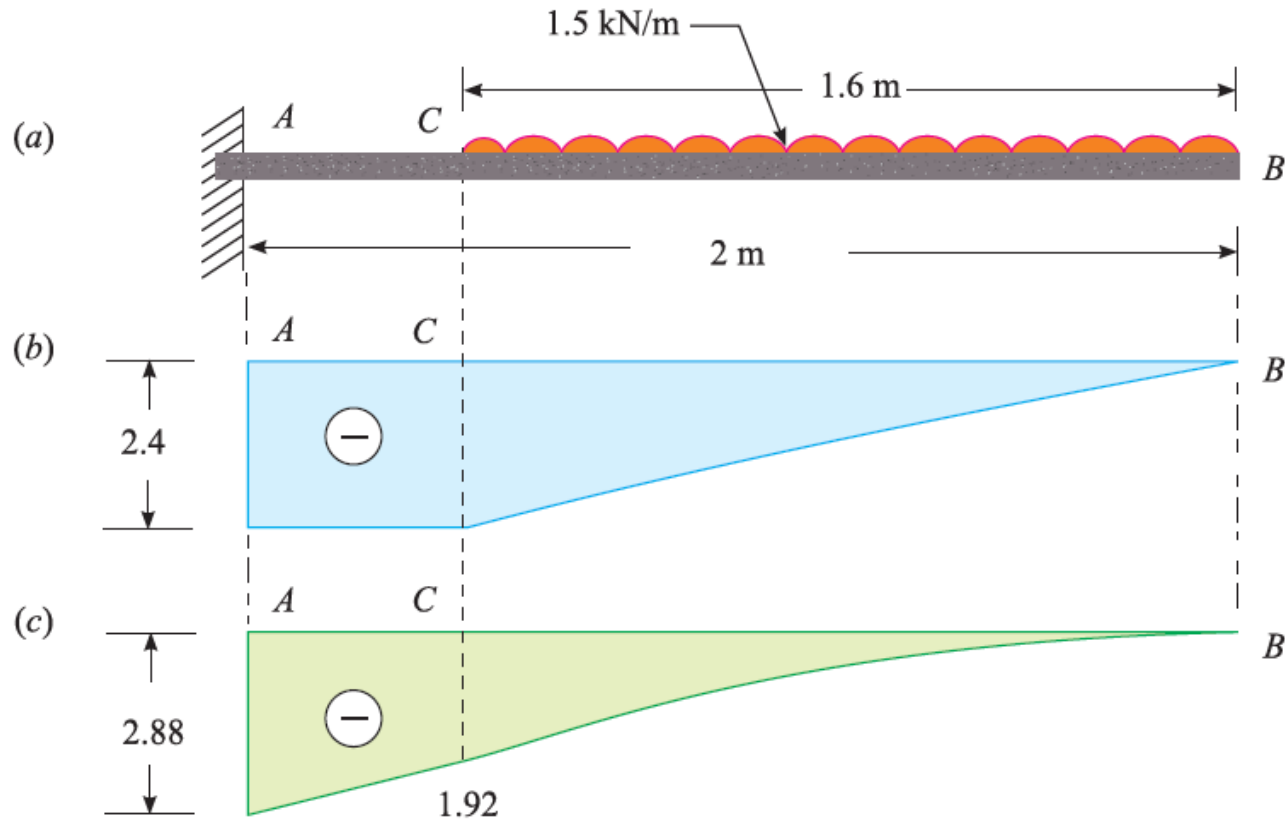

Fig. 13.5

NOTE. The bending moment at A is the moment of the load between C and B (equal to $1.5 \times 1.6 = 2.4$ kN) about A. The distance between the centre of the load and A is $0.4 + \frac{1.6}{2} = 1.2$ m.



EXAMPLE 13.3. A cantilever beam of 1.5 m span is loaded as shown in Fig. 13.6 (a). Draw the shear force and bending moment diagrams.

SOLUTION. Given : Span (l) = 1.5 m ; Point load at B (W) = 2 kN ; Uniformly distributed load (w) = 1 kN/m and length of the cantilever AC carrying the load (a) = 1 m.

Shear force diagram

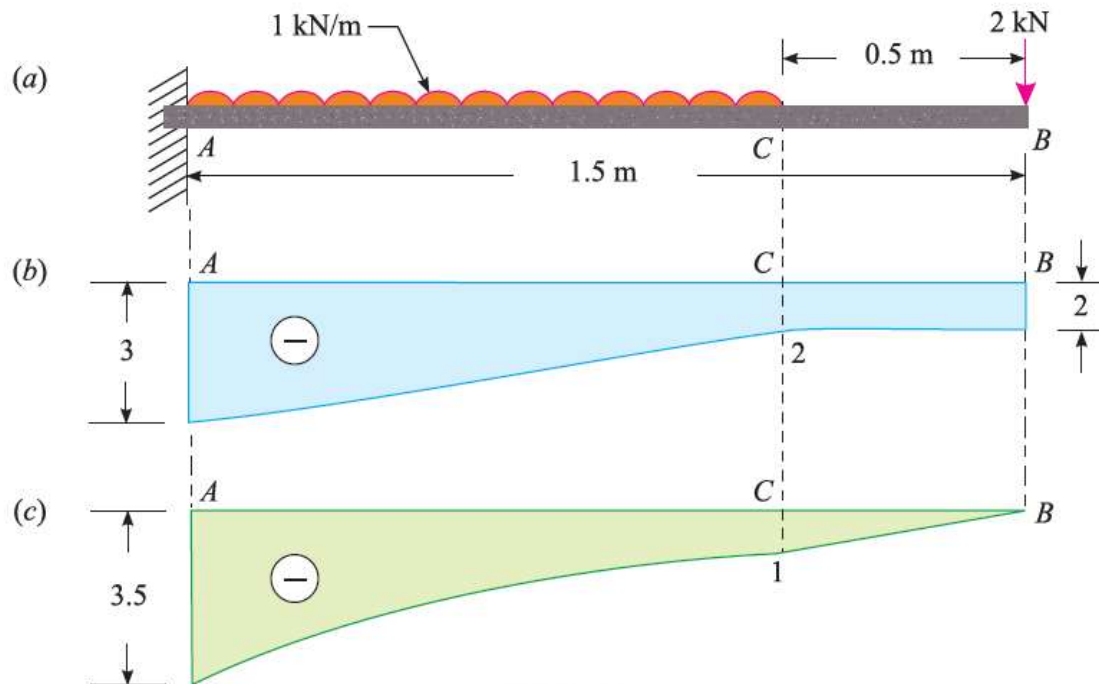

Fig. 13.6

The shear force diagram is shown in Fig. 13.6 (b) and the values are tabulated here:

$$F_B = -W = -2 \text{ kN}$$

$$F_C = -2 \text{ kN}$$

$$F_A = -[2 + (1 \times 1)] = -3 \text{ kN}$$



The shear force diagram is shown in Fig. 13.6 (b) and the values are tabulated here:

$$F_B = -W = -2 \text{ kN}$$

$$F_C = -2 \text{ kN}$$

$$F_A = -[2 + (1 \times 1)] = -3 \text{ kN}$$

Bending moment diagram

The bending moment diagram is shown in Fig. 13.6 (c) and the values are tabulated here:

$$M_B = 0$$

$$M_C = -[2 \times 0.5] = -1 \text{ kN-m}$$

$$M_A = -\left[(2 \times 1.5) + (1 \times 1) \times \frac{1}{2}\right] = -3.5 \text{ kN-m}$$



EXAMPLE 13.6. A simply supported beam AB of span 2.5 m is carrying two point loads as shown in Fig. 13.13.

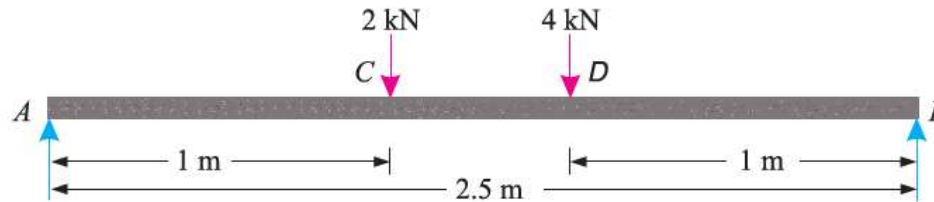

Fig. 13.13

Draw the shear force and bending moment diagrams for the beam.

SOLUTION. Given : Span (l) = 2.5 m ; Point load at C (W_1) = 2 kN and point load at B (W_2) = 4 kN .

First of all let us find out the reactions R_A and R_B . Taking moments about A and equating the same,

$$R_B \times 2.5 = (2 \times 1) + (4 \times 1.5) = 8$$

$$R_B = 8/2.5 = 3.2\text{ kN}$$

and

$$R_A = (2 + 4) - 3.2 = 2.8\text{ kN}$$

Shear force diagram

The shear force diagram is shown in Fig. 13.14 (b) and the values are tabulated here:

$$F_A = +R_A = 2.8\text{ kN}$$

$$F_C = +2.8 - 2 = 0.8\text{ kN}$$

$$F_D = 0.8 - 4 = -3.2\text{ kN}$$

$$F_B = -3.2\text{ kN}$$



Bending moment diagram

The bending moment diagram is shown in Fig. 13.14 (c) and the values are tabulated here:

$$M_A = 0$$

$$M_C = 2.8 \times 1 = 2.8 \text{ kN-m}$$

$$M_D = 3.2 \times 1 = 3.2 \text{ kN-m}$$

$$M_B = 0$$

NOTE. The value of M_D may also be found and from the reaction R_A . *i.e.*,

$$M_D = (2.8 \times 1.5) - (2 \times 0.5) = 4.2 - 1.0 = 3.2 \text{ kN-m}$$

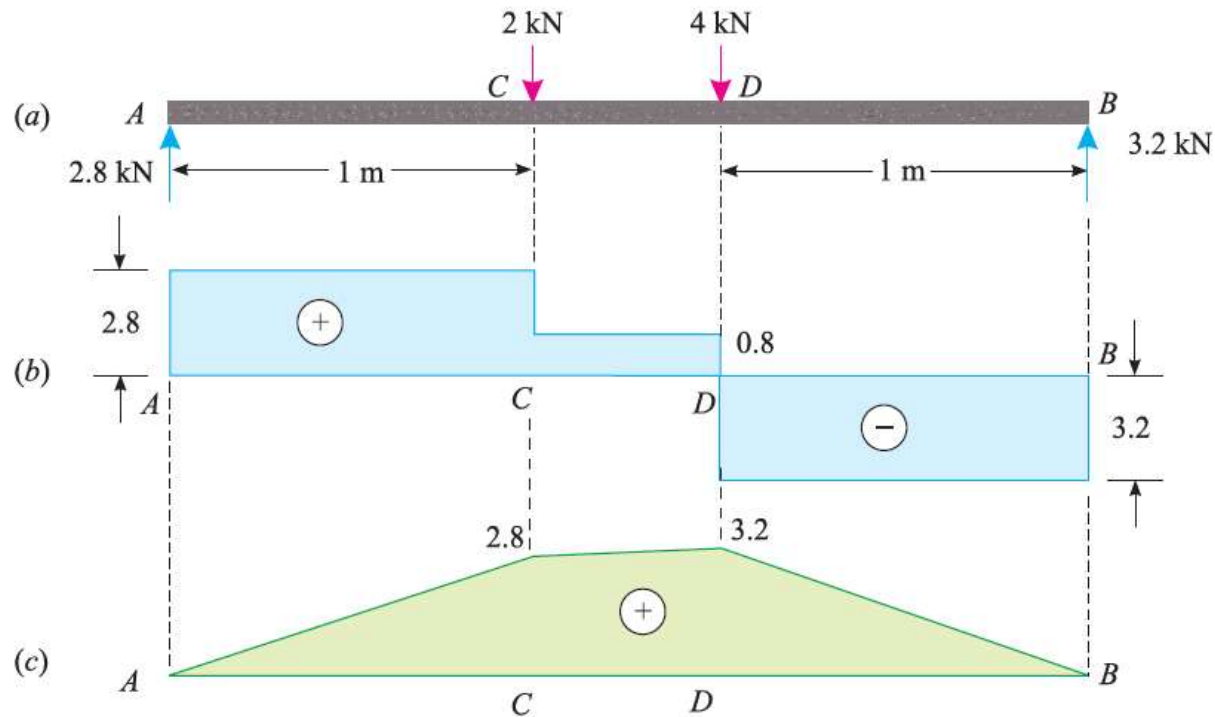



EXAMPLE 13.7. A simply supported beam 6 m long is carrying a uniformly distributed load of 5 kN/m over a length of 3 m from the right end. Draw the S.F. and B.M. diagrams for the beam and also calculate the maximum B.M. on the section.

SOLUTION. Given : Span (l) = 6 m ; Uniformly distributed load (w) = 5 kN/m and length of the beam CB carrying load (a) = 3 m.

First of all, let us find out the reactions R_A and R_B . Taking moments about A and equating the same,

$$R_B \times 6 = (5 \times 3) \times 4.5 = 67.5$$

$$\therefore R_B = \frac{67.5}{6} = 11.25 \text{ kN}$$

and $R_A = (5 \times 3) - 11.25 = 3.75 \text{ kN}$

Shear force diagram

The shear force diagram is shown in Fig. 13.16 (b) and the values are tabulated here:

$$F_A = + R_A = + 3.75 \text{ kN}$$

$$F_C = + 3.75 \text{ kN}$$

$$F_B = + 3.75 - (5 \times 3) = - 11.25 \text{ kN}$$



Bending moment diagram

The bending moment is shown in Fig. 13.16 (c) and the values are tabulated here:

$$M_A = 0$$

$$M_C = 3.75 \times 3 = 11.25 \text{ kN}$$

$$M_B = 0$$

We know that the maximum bending moment will occur at M , where the shear force changes sign. Let x be the distance between C and M . From the geometry of the figure between C and B , we find that

$$\frac{x}{3.75} = \frac{3-x}{11.25} \quad \text{or} \quad 11.25x = 11.25 - 3.75x$$

$$15x = 11.25 \quad \text{or} \quad x = 11.25/15 = 0.75 \text{ m}$$

$$\therefore M_M = 3.75 \times (3 + 0.75) - 5 \times \frac{0.75}{2} = 12.66 \text{ kN-m}$$

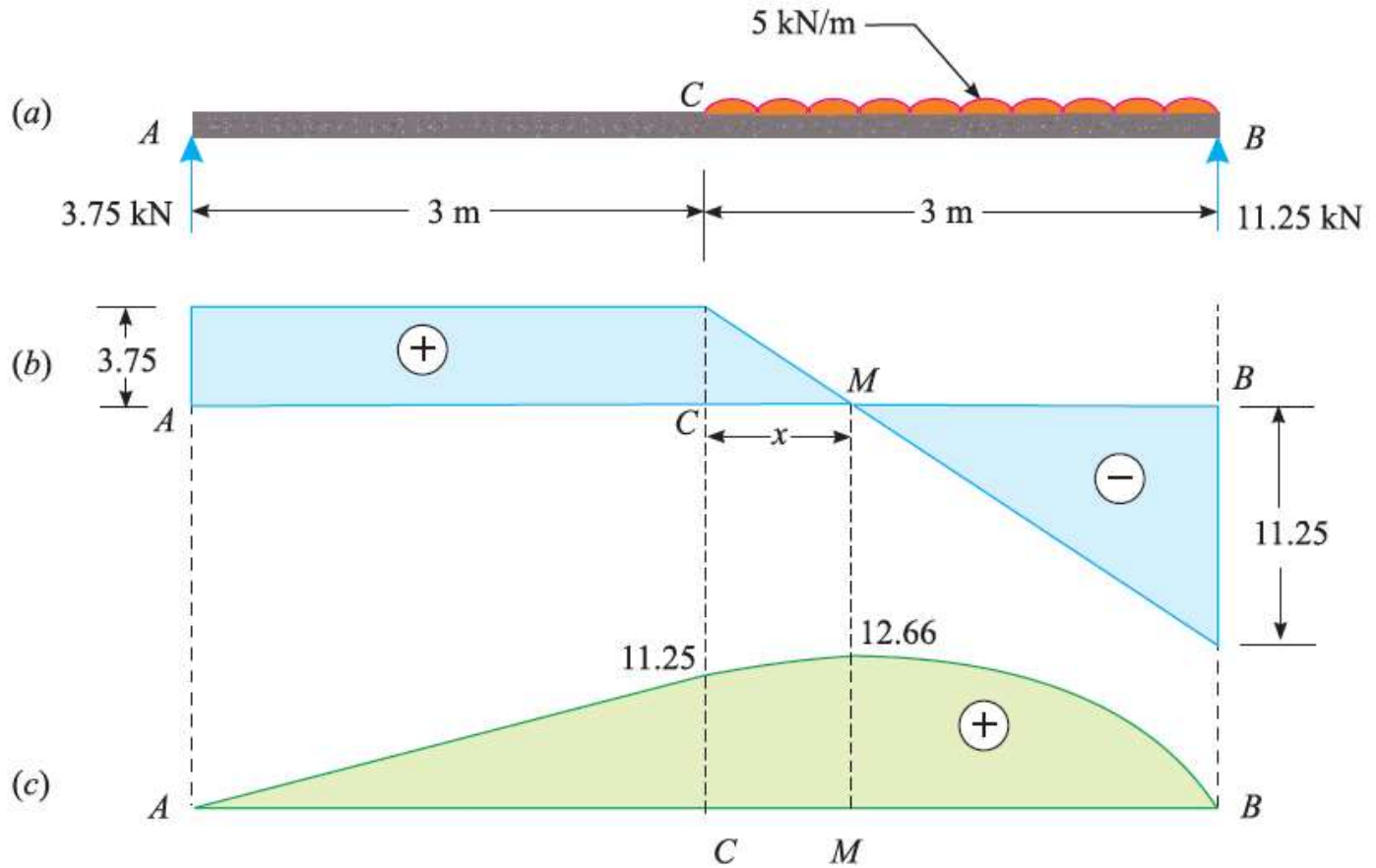



EXAMPLE 13.8. A simply supported beam 5 m long is loaded with a uniformly distributed load of 10 kN/m over a length of 2 m as shown in Fig. 13.17.

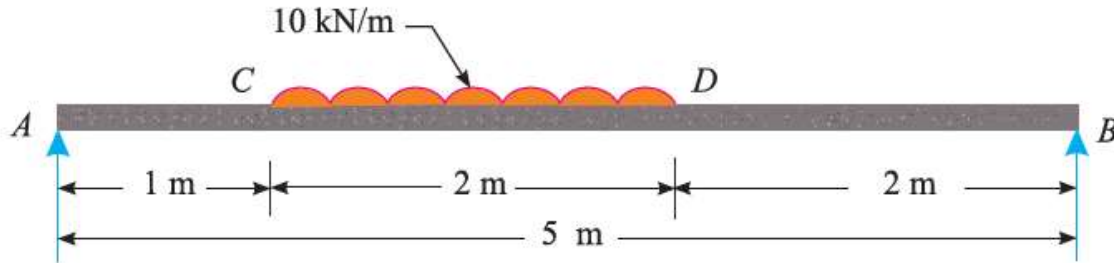

Fig. 13.17

Draw shear force and bending moment diagrams for the beam indicating the value of maximum bending moment.

SOLUTION. Given : Span (l) = 5 m ; Uniformly distributed load (w) = 10 kN/m and length of the beam CD carrying load (a) = 2 m.

First of all, let us find out the reactions R_A and R_B . Taking moments about A and equating the same,

$$R_B \times 5 = (10 \times 2) \times 2 = 40$$

$$\therefore R_B = 40/5 = 8 \text{ kN}$$

$$\text{and } R_A = (10 \times 2) - 8 = 12 \text{ kN}$$



Shear force diagram

The shear force diagram is shown in Fig. 13.18 (b) and the values are tabulated here:

$$F_A = +R_A = +12 \text{ kN}$$

$$F_C = +12 \text{ kN}$$

Bending moment diagram

The bending moment diagram is shown in Fig. 13.18 (c) and the values are tabulated here:

$$M_A = 0$$

$$M_C = 12 \times 1 = 12 \text{ kN-m}$$

$$M_D = 8 \times 2 = 16 \text{ kN-m}$$

We know that maximum bending moment will occur at M , where the shear force changes sign. Let x be the distance between C and M . From the geometry of the figure between C and D , we find that

$$\frac{x}{12} = \frac{2-x}{8} \quad \text{or} \quad 8x = 24 - 12x$$

$$20x = 24 \quad \text{or} \quad x = 24/20 = 1.2 \text{ m}$$

$$M_M = 12(1 + 1.2) - 10 \times 1.2 \times \frac{1.2}{2} = 19.2 \text{ kN-m}$$

