



## Hydrogen as a fuel, Production and Storage

- Hydrogen is the chemical element with the symbol H and atomic number 1.
- It is the lightest element in the periodic table. Moreover, it is the **most abundant chemical substance** in the universe.
- However, the most common element in nature is **not available freely**. Hydrogen also exists only in combination with other elements. Thus, it has to be extracted from natural compounds, like water.
- Hydrogen acts as a chemical energy carrier, rather like oil or gas that can be piped or transported to where it is needed. It stores three times as much energy per unit of mass as conventional petrol, and when it “burns” in air –releasing that stored energy– it simply combines with oxygen to produce water again.

The various methods of production of hydrogen

### 1 Electrolysis of water

It is the simplest method which consists of two electrodes immersed in an aqueous solution called electrolyte. When direct current is passed through the cell, it decomposes water into hydrogen and oxygen, Oxygen is formed at anode and hydrogen at cathode. Metal or carbon plates are used as electrodes Aqueous KOH solution is used as electrolyte.

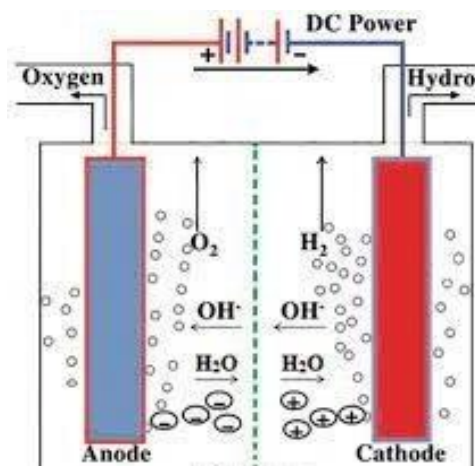



A decomposition voltage of 2V is applied. The chemical reaction of decomposition of water are

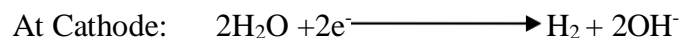
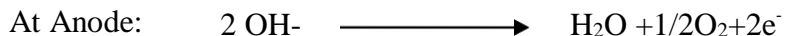

## Thermo chemical method

This method consist of steam reforming of natural gas to produce hydrogen, it is most efficient cost effective and commercial Technology. The natural gas consisting of methane and Carbon monoxide is reformed with the help of steam at 900°C to produce a mixture of H<sub>2</sub> and CO<sub>2</sub>. CO<sub>2</sub> is removed at the later stage by scrubbing process to get hydrogen

The reaction involved is are

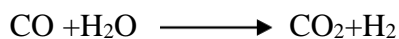
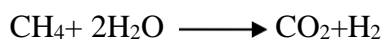

## Thermolysis of water

It is the process of producing hydrogen by splitting water directly using heat energy. The thermolysis requires a high temperature of about 2500 °C. To carry out thermolysis at low temperature of about 850 °C the process is carried out in different stages by using chemical materials.

## Biophotolysis

The method uses the ability of plants such Cyanobacteria (also called blue-green algae) algae to generate hydrogen gas when these plants are exposed to water and sunlight. The hydrogen gas can be produced by this method at a low cost. Since this process is essentially decomposition of water using solar energy in presence of biological catalyst it is called biophotolysis of water

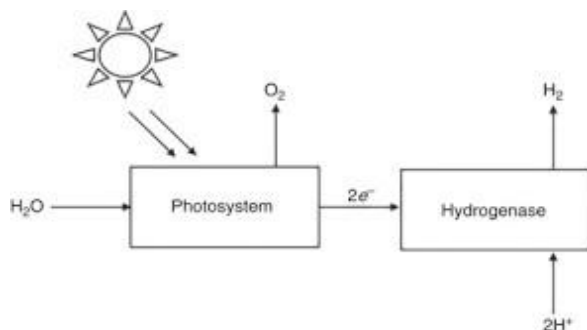

Note: Hydrogenases are enzymes capable of producing or up taking molecular hydrogen.

## Storage

- Storing and transporting of liquid hydrogen (20k) is expensive. density only  $0.07\text{g/cm}^3$
- High pressure equipments (steel cylinder) is also expensive and heavy
- Diffusion of  $\text{H}_2$  through container is a serious problem.
- Early reports of  $>50\%$  of  $\text{H}_2$  Storage in nano tubes were wrong
- Metal Hydrides  $\text{LiAlH}_4$ —Promising, but highly reactive and requires high T for hydrogen recovery.
- No practical solid state storage exists yet.
- The most common storage systems are high-pressure gas cylinders with a maximum pressure of 20 MPa (200bar). New light weight composite cylinders have been developed which are able to withstand pressures up to 80 MPa (800 bar) and therefore the hydrogen gas can reach a volumetric density of 36 kg.

## Applications

- Hydrogen is currently used in industrial processes, as rocket fuel, and in fuel cells for electricity generation and powering vehicles.
- Many natural gas-fired power plant operators are inspecting the possibility of using hydrogen in place of or in addition to natural gas.