

**Basic Civil  
and  
Mechanical Engineering**

# ABOUT THE AUTHORS

**G Shanmugam** obtained his BE in Mechanical Engineering in 1951 from the College of Engineering, Guindy, Chennai, and ME in IC Engines in 1958 from Purdue University, USA, where he had an opportunity to serve as a part-time teaching Assistant. During his distinguished academic career, he has been in the teaching profession for the past 65 years, out of which he has taught abroad for 20 years. He has served as Professor of Mechanical Engineering at PSG College of Technology, Coimbatore, University of Basrah, Iraq, and Gulf Polytechnic, Bahrain. As founder Principal, he served in Mepco Schlenk Engineering College for a period of 18 years and developed it as the *numero uno* Technical Institution in Tamil Nadu. The college received the first National Award as the Best Engineering College in 1998 from ISTE, instituted by Bharatiya Vidya Bhavan, Mumbai.

Prof. Shanmugam has received more than 13 personal awards at the regional, state and national levels including the Best Principal Award, Outstanding Engineer Award, Achiever Award and many more. He is a fellow of the Institution of Engineers (India), Kolkata. He is a Life Member of ISTE Quality Forum of India and Acoustic Society of India. At present, even at the age of 88, he is actively serving as Advisor at Kamaraj College of Engineering and Sri Vidya College of Engineering. He is also a member of the Governing Council at Dhanalakshmi College of Engineering, Chennai. He is a widely travelled person having visited more than 17 countries so far. He has recently authored an autobiography titled *Secret of Success* and this book is being distributed to many school, college and polytechnic libraries, free of cost.

**M S Palanichamy** obtained a bachelor's degree in Civil Engineering from PSG College of Technology and MTech and PhD degrees from the Indian Institute of Technology Madras, Chennai. His teaching experience spans over 43 years.

He was a faculty of Anna University in the Structural Engineering Department for a decade. He served as the Professor and Head of Civil Engineering Department and then as the Principal of Mepco Schlenk Engineering College, Sivakasi. Later he served as the Vice Chancellor of Tamil Nadu Open University, Chennai, for two terms and Vice Chairman of Tamil Nadu State Council for Technical Education. Currently, he is serving as the Advisor of RMK Group of Engineering Colleges, Kavaraipettai, Chennai. He has published six books and 60 papers in his professional career. Also, four candidates have obtained their PhD degrees under his guidance.

He is a member of various professional bodies like American Concrete Institute (ACI), Institution of Engineers (India), Indian Concrete Institute (ICI), Institution of Valuers, etc., and he has also served as the member of National Executive Council of the Indian Society of Technical Education and All India Council for Technical Education and as member of Engineering Accreditation Committee, NBA, New Delhi. He was the Chairman, Board of Studies, Civil Engineering, of Madurai Kamaraj University and Anna University.

He has been conferred with many awards such as Lifetime Achievement Award and Honorary Fellowship by the Indian Society for Technical Education at State and National Level respectively, Live Award by Loyola College, Chennai, and France Heritage Award by Gavoty Foundation, France.

At present, he is serving in the governing councils of many technical institutions and private universities in Tamil Nadu.

# Basic Civil and Mechanical Engineering

**G Shanmugam**

*Advisor, Kamaraj College of Engineering and Technology  
Sri Vidya College of Engineering and Technology  
Founder Principal  
Mepco Schlenk Engineering College, Sivakasi*

**M S Palanichamy**

*Advisor, RMK Group of Engineering Colleges, Chennai  
Former Principal  
Mepco Schlenk Engineering College, Sivakasi  
&  
Former Vice Chancellor  
Tamil Nadu Open University, Chennai*



**McGraw Hill Education (India) Private Limited**  
CHENNAI

---

*McGraw Hill Education Offices*

**Chennai** New York St Louis San Francisco Auckland Bogotá Caracas  
Kuala Lumpur Lisbon London Madrid Mexico City Milan Montreal  
San Juan Santiago Singapore Sydney Tokyo Toronto



**McGraw Hill Education (India) Private Limited**

Published by McGraw Hill Education (India) Private Limited  
444/1, Sri Ekambara Naicker Industrial Estate, Alapakkam, Porur, Chennai 600 116

## **Basic Civil and Mechanical Engineering**

Copyright © 2018 by McGraw Hill Education (India) Private Limited.

No part of this publication may be reproduced or distributed in any form or by any means, electronic, mechanical, photocopying, recording, or otherwise or stored in a database or retrieval system without the prior written permission of the publishers. The program listings (if any) may be entered, stored and executed in a computer system, but they may not be reproduced for publication.

This edition can be exported from India only by the publishers,  
McGraw Hill Education (India) Private Limited.

1 2 3 4 5 6 7 8 9 D103074 22 21 20 19 18

Printed and bound in India.

ISBN (13): 978-93-87572-31-7

ISBN (10): 93-87572-31-5

Vice President—Finance & Operations: *Ashutosh Verma*

Director—Science & Engineering Portfolio: *Vibha Mahajan*

Senior Manager Portfolio—Science & Engineering: *Hemant K Jha*

Associate Portfolio Manager—Science & Engineering: *Mohammad Salman Khurshid*

Production Head: *Satinder S Baveja*

Copy Editor: *Taranpreet Kaur*

Assistant Manager—Production: *Anuj K Shrivastava*

General Manager—Production: *Rajender P Ghansela*

Manager—Production: *Reji Kumar*

Information contained in this work has been obtained by McGraw Hill Education (India), from sources believed to be reliable. However, neither McGraw Hill Education (India) nor its authors guarantee the accuracy or completeness of any information published herein, and neither McGraw Hill Education (India) nor its authors shall be responsible for any errors, omissions, or damages arising out of use of this information. This work is published with the understanding that McGraw Hill Education (India) and its authors are supplying information but are not attempting to render engineering or other professional services. If such services are required, the assistance of an appropriate professional should be sought.

Typeset at APS Compugraphics, 4G, PKT 2, Mayur Vihar Phase-III, Delhi 96, and printed at

Cover Printer:

Visit us at: [www.mheducation.co.in](http://www.mheducation.co.in)

*Dedicated to our parents*

*Late Sri C Gurusamy Nadar*

*&*

*Late Smt. Sivahami Ammal*

*– G Shanmugam*

*Late Sri K M Selliah Thevar*

*&*

*Late Smt. Seethalakshmi Ammal*

*– M S Palanichamy*



# PREFACE

*Unit 1, 2 and 3* of this book concisely covers the syllabus for the Civil Engineering part of the Basic Civil and Mechanical Engineering course. It will be useful not only to the first year engineering students, but also to diploma and AMIE students. It will also serve as a good reference material for those preparing for competitive examinations.

This book is presented in a simple and comprehensive manner. Solved problems and illustrative diagrams have been included to explain the various concepts. Exercises are appended at the end of each chapter to provide adequate practice to the students and to help them comprehend the subject. It covers all the latest topics included in the syllabi to help students in learning and teachers in classroom teaching.

I am thankful to the Management of Mepco Schlenk Engineering College, Sivakasi, and R M K Group of Engineering Colleges, Kavaraipettai, Chennai, for their encouragement in completing this project. I express my gratitude to the faculty of Civil Engineering Department for the help extended to me at various stages of the project, when I was serving at Mepco Schlenk Engineering College.

I convey my thanks and appreciation to McGraw Hill Education (India) in bringing out this high-quality edition in a short span of time.

**M S PALANICHAMY**

*Unit 1, 4 and 5* of this book covers the syllabus for the Mechanical Engineering part of the Basic Civil and Mechanical Engineering course, which caters to the first year engineering students.

Throughout the text, an attempt has been made to present the subject matter in a simple, lucid and precise manner. More than two illustrations, supported by simple theoretical presentations, help in easy understanding of the concepts. Great care has been taken to make the text student- and teacher-friendly. Varieties of questions are appended at the end of each chapter to provide adequate practice to the students and to help them comprehend the subject. All the topics have been included as per the latest syllabus.

I express my gratitude to the support rendered by my son, Dr S Ravindran, Mechanical Engineering Department, Hindustan Institute of Science and Technology, Hindustan University, Chennai, in helping me with preparation and finalization of the manuscript.

I convey my thanks and appreciation to McGraw Hill Education (India) in bringing out this high-quality edition in a short time span.

**G SHANMUGAM**



# CONTENTS

*Preface*

*vii*

## **UNIT 1 SCOPE OF CIVIL AND MECHANICAL ENGINEERING**

<b>1. Scope of Civil Engineering</b>	<b>1.1–82</b>
1.1 Civil Engineering	1.1
1.2 Smart City Development – Infrastructure Development	1.34
1.3 Role of Civil Engineers	1.35
1.4 Civil Engineering Contribution to the Welfare of Society	1.36
1.5 Ethical Principle	1.38
1.6 Contribution of Mechanical Engineering to the Society	1.39
1.7 Introduction to Metal Casting Process	1.39
1.8 Advantages of the Casting Process	1.39
1.9 Patterns	1.40
1.10 Moulding	1.47
1.11 Melting of Cast Iron	1.53
1.12 Cupola Furnace	1.53
1.13 Crucible Furnace	1.56
1.14 Fettling	1.58
1.15 Casting Defects	1.58
1.16 Introduction to Metal Joining Processes	1.59
1.17 Welding	1.59
1.18 Arc Welding	1.61
1.19 Gas Welding	1.63
1.20 Gas Cutting	1.65
1.21 Brazing	1.65
1.22 Soldering	1.67

- 1.23 Lathe 1.68
- 1.24 Drilling Machines 1.74
- 1.25 Automobile 1.75
- 1.26 Energy Engineering 1.75
- 1.27 Interdisciplinary Concepts in civil and Mechanical Engineering 1.75
  - Short-Answer Questions* 1.78
  - Exercises* 1.81

## **UNIT 2 SURVEYING AND SCOPE OF CIVIL ENGINEERING MATERIALS**

- 2. Surveying** **2.1–2.40**
  - 2.1 Introduction 2.1
  - 2.2 Importance of Surveying 2.1
  - 2.3 Objectives of Surveying 2.1
  - 2.4 Types of Surveying 2.1
  - 2.5 Classification of Surveys 2.2
  - 2.6 Principles of Surveying 2.4
  - 2.7 Measurement of Distances 2.5
  - 2.8 Measurement of Angles 2.9
  - 2.9 Levelling 2.17
  - 2.10 Determination of Areas 2.25
  - 2.11 Contouring 2.29
    - Illustrative Examples* 2.32
    - Short-Answer Questions* 2.36
    - Exercises* 2.36
  
- 3. Civil Engineering and Materials** **3.1–3.55**
  - 3.1 Introduction 3.1
  - 3.2 Civil Engineering 3.1
  - 3.3 Construction Materials—Bricks 3.5
  - 3.4 Stones 3.10
  - 3.5 Cement 3.15
  - 3.6 Cement Concrete 3.23
  - 3.7 Steel Sections 3.34
  - 3.8 Wood 3.42
  - 3.9 Plastics 3.47
  - 3.10 Properties of Building Materials 3.49
    - Short-Answer Questions* 3.52
    - Exercises* 3.54

---

**UNIT 3 BUILDING COMPONENTS AND STRUCTURES**

- 4. Foundation** **4.1–4.31**
- 4.1 Selection of Site 4.1
  - 4.2 Substructure 4.2
  - 4.3 Objectives of a Foundation 4.2
  - 4.4 Site Inspection 4.3
  - 4.5 Soils 4.3
  - 4.6 Loads on Foundations 4.6
  - 4.7 Essential Requirements of a Good Foundation 4.7
  - 4.8 Types of Foundation 4.7
  - 4.9 Caisson Foundation or Well Foundation 4.16
  - 4.10 Failure of Foundations and Remedial Measures 4.17
  - 4.11 Foundations for Machinery 4.18
  - 4.12 Foundations for Special Structures 4.21
    - Short-Answer Questions* 4.30
    - Exercises* 4.31
- 5. Superstructure** **5.1–5.66**
- 5.1 Introduction 5.1
  - 5.2 Brick Masonry 5.1
  - 5.3 Stone Masonry 5.9
  - 5.4 RCC Structural Members 5.18
  - 5.5 Columns 5.23
  - 5.6 Lintels 5.25
  - 5.7 Roofing 5.28
  - 5.8 Flooring 5.40
  - 5.9 Damp-Proofing 5.51
  - 5.10 Plastering 5.54
  - 5.11 Valuation 5.57
    - Illustrative Examples* 5.61
    - Short-Answer Questions* 5.63
    - Exercises* 5.65
- 6. Bridges** **6.1–6.18**
- 6.1 Introduction 6.1
  - 6.2 Necessity of Bridges 6.1
  - 6.3 Site Investigation 6.1
  - 6.4 Preliminary Data to be Collected 6.2

- 6.5 Components of a Bridge 6.3
- 6.6 Technical Terms 6.5
- 6.7 Classification of Bridges 6.6
- 6.8 Culverts 6.14
- 6.9 Causeways 6.16
- Short-Answer Questions* 6.18

**7. Dams****7.1–7.14**

- 7.1 Introduction 7.1
- 7.2 Purpose of Dams 7.2
- 7.3 Components of a Reservoir 7.2
- 7.4 Selection of Site 7.2
- 7.5 Classification of Dams 7.3
- 7.6 Geological Effects 7.12
- Short-Answer Questions* 7.13
- Exercises* 7.13

**UNIT 4 INTERNAL COMBUSTION ENGINES AND POWER PLANTS****8. Power Plants, Gas Turbines and Alternate Sources of Energy****8.1–8.27**

- 8.1 Introduction 8.1
- 8.2 Classification of Power Plants 8.1
- 8.3 Steam Power Plants 8.1
- 8.4 Nuclear Power Plant 8.3
- 8.5 Gas Turbines 8.7
- 8.6 Diesel Power Plant 8.10
- 8.7 Hydroelectric Power Plant 8.12
- 8.8 Environmental Constraints of Power Generation 8.14
- 8.9 Alternate Sources of Energy 8.15
- Short-Answer Questions* 8.25
- Exercises* 8.27

**9. Steam Boilers and Steam Turbines****9.1–9.21**

- 9.1 Introduction 9.1
- 9.2 Formation of Steam 9.1
- 9.3 Cochran Boiler 9.2
- 9.4 Boiler Mountings 9.4
- 9.5 Locomotive Boiler 9.7
- 9.6 Babcock and Wilcox Boiler 9.8

---

9.7 Lamont Boiler	9.9	
9.8 Benson Boiler	9.10	
9.9 Advantages of High Pressure Boilers	9.11	
9.10 Characteristics of a Good Boiler	9.11	
9.11 Indian Boiler Act	9.12	
9.12 Differences between Fire-Tube and Water-Tube Boilers	9.12	
9.13 Cogeneration	9.12	
9.14 Introduction to Steam Turbines	9.13	
9.15 Main Parts of a Steam Turbine	9.13	
9.16 Types of Turbines	9.14	
9.17 Working of a Single-Stage Impulse Turbine (De-Laval Turbine)	9.14	
9.18 Compounding of Impulse Steam Turbines	9.15	
9.19 Working of Parson's Reaction Turbine	9.16	
9.20 Differences between Impulse and Reaction Turbines	9.18	
<i>Short-Answer Questions</i>	9.18	
<b>10. Pumps</b>		<b>10.1–10.8</b>
10.1 Application of Pumps	10.1	
10.2 Classification	10.2	
10.3 Reciprocating Pumps	10.2	
10.4 Centrifugal Pumps	10.4	
<i>Short-Answer Questions</i>	10.7	
<b>11. IC Engine</b>		<b>11.1–11.24</b>
11.1 Introduction	11.1	
11.2 Classification of IC Engines	11.1	
11.3 Main Components of IC Engines	11.2	
11.4 Working of a Four-Stroke Petrol Engine	11.4	
11.5 Working of a Four-Stroke Diesel Engine	11.7	
11.6 Differences between Petrol Engines and Diesel Engines	11.7	
11.7 Working of a Two-Stroke Petrol Engine	11.8	
11.8 Working of a Two-Stroke Diesel Engine	11.10	
11.9 Differences between a 4-Stroke and a 2-Stroke Engine	11.11	
11.10 Fuel System in a Petrol Engine	11.11	
11.11 Battery or Coil-Ignition System	11.13	
11.12 Cooling System in IC Engines	11.15	
11.13 Lubrication System	11.17	
11.14 Fuel System for Diesel Engines	11.19	

- 11.15 Petrol Injection 11.20  
 11.16 Difference between Diesel Injection and Petrol Injection 11.22  
*Short-Answer Questions* 11.22

## UNIT 5 REFRIGERATION AND AIR-CONDITIONING SYSTEM

### 12. Refrigeration and Air Conditioning 12.1–12.14

#### Part A Refrigeration

- 12.1 Introduction 12.1  
 12.2 Unit of Refrigeration 12.1  
 12.3 Performance of a Refrigerator 12.1  
 12.4 Applications of Refrigeration 12.2  
 12.5 Refrigerants 12.2  
 12.6 Desirable Properties of Refrigerants 12.2  
 12.7 Types of Refrigerants 12.2  
 12.8 Methods of Refrigeration 12.3  
 12.9 Comparison between Vapour-Compression and  
 Vapour-Absorption System 12.6  
 12.10 Solar Refrigerator/Air-Conditioning System 12.6

#### Part B Air Conditioning

- 12.11 Introduction 12.6  
 12.12 Applications of Air Conditioning 12.7  
 12.13 Important Terminology in Air Conditioning 12.7  
 12.14 Requirements of Comfort Air Conditioning 12.7  
 12.15 Window Air Conditioner 12.7  
 12.16 Split Air-Conditioner 12.9  
 12.17 Central Air Conditioning 12.10  
 12.18 Thermoelectric Cooling 12.11  
*Short-Answer Questions* 12.12  
*Exercises* 12.13

<i>Short Questions and Answers</i>	S.1–S.13
<i>Model Question Paper-1</i>	MQP.1–MQP.3
<i>Model Question Paper-2</i>	MQP.4–MQP.5
<i>Model Question Paper-3</i>	MQP.6–MQP.7
<i>Index</i>	I.1–I.10

## **UNIT-1**

# **SCOPE OF CIVIL AND MECHANICAL ENGINEERING**





# Chapter 1

## SCOPE OF CIVIL ENGINEERING

### 1.1 CIVIL ENGINEERING

Civil Engineering is the field of engineering concerned with planning, design and construction for environmental control, development of natural resources, buildings, transportation facilities and other structures required for health, welfare, safety, employment and pleasure of mankind.

The main scope of civil engineering or the task of civil engineering is planning, designing, estimating, supervising construction, execution, and maintenance of structures like building, roads, bridges, dams, etc.

Population demographics along with increasing urbanization have facilitated the need for sustainable and efficient infrastructure solutions. Development in green buildings, sensor-embedded roads and buildings, geopolymer concrete, and water management will stimulate global civil engineering industry growth.

#### 1.1.1 Field of Civil Engineering

Civil engineering is a wide field and includes many types of structures such as residential buildings, public buildings, industrial buildings, roads, bridges, tunnels, railways, dams, canal and canal structures, airports, harbours, ports, water treatment plants, waste water treatment plants, water supply networks, and drainage networks. It also covers environmental protection, irrigation and water resources, soil investigations and foundations, transport systems management, etc.

#### 1.1.2 Specialized Disciplines in Civil Engineering

Civil engineering may be divided into the following fields:

- Building materials
- Building construction
- Structural engineering
- Geotechnical engineering
- Hydraulics, water resources and irrigation engineering

- Water supply and sanitary engineering
- Environmental engineering
- Transportation engineering
- Town planning and architecture
- Surveying
- Drawing
- Estimation and specification
- Management techniques
- Computer application

### **1.1.3 Building Materials**

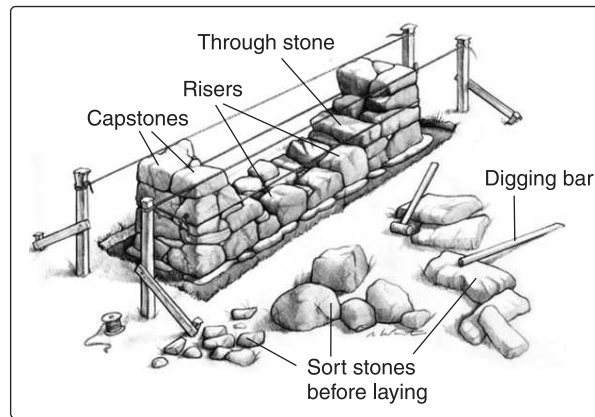
- Shelter is the basic need of civilized society. Stones, bricks, timber and lime concrete are the traditional materials used for the construction of houses and other buildings.
- The invention of cement and concrete has provided durable buildings.
- Reinforced concrete which is composite construction of steel and concrete has helped in building large structures.
- Steel, aluminium, glass, plastics, glazed tiles, plaster of Paris, linoleum, paints and varnishes have improved the quality of buildings.
- Improved versions of many building materials keep on appearing in the market regularly. A civil engineer has to make use of all these materials judiciously.

### **1.1.4 Building Construction**

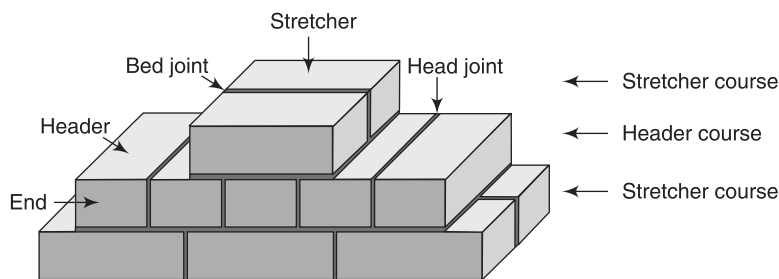
Construction Engineering is a professional discipline that deals with the designing, planning, construction, and management of infrastructures such as roads, tunnels, bridges, airports, railroads, facilities, buildings, dams, utilities and other projects. It is considered a professional sub-practice area of civil engineering or architectural engineering.

The following stages are carried out for any type of project:

1. In the beginning, technical feasibility, environmental impact assessment and economical viability of the project are studied.
2. Soil investigation includes collecting data regarding soil and bearing capacity of soil. Soil investigations are done for the purpose of foundation design.
3. Surveying includes preparing site plan, contour map and measurement of field dimensions and levels.
4. On the basis of the data collected, planning and designing are carried out and drawings are prepared. Buildings are planned according to the fundamental principles of planning and by laws of local municipal bodies. Building planning also requires basic knowledge of principles of architecture.



**Fig 1.1** *Bonding of Stone Masonry*



**Fig 1.2** *Bonding of Brick Masonry*

5. Estimates are prepared to know the probable cost of completion of work and detailed planning and scheduling are prepared to carry out different activities in time without any delay.

**I. During Construction** Owner, engineer and contractor are the three constituents of a construction team in engineering profession, hence continuous liaison among themselves is very essential for the speedy progress of the work. Execution of work is actual construction carried out on the site with materials and equipment, by skilled and unskilled work force, under the technical guidance and supervision of engineer in charge. During construction, engineer has to supervise the work carried out as per the specifications for quality control. Costing is the accounts procedure of arriving at the actual cost of construction.

**II. After Construction** Maintenance and repairs, valuation after the construction, regular maintenance of structures are to be carried out. Valuation is carried out for the purpose of sale, purchase and many others.

### **III. Importance of Construction Management and its Functions**

- It gives guidelines regarding the execution of construction work to be carried out.

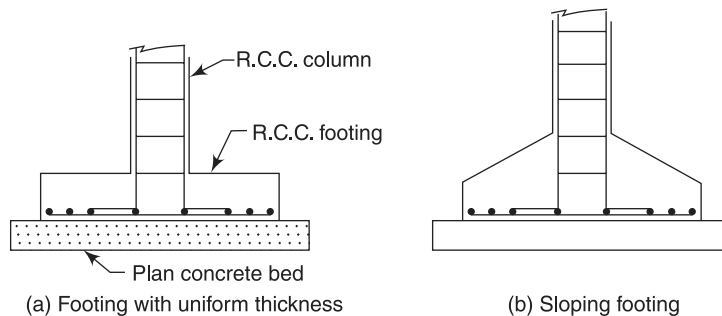
- It helps in preparing construction schedule. Schedule is a systematic path of different activities carried out one after another. It helps in defining goals and planning procedure.
- It helps in proper management of material, labour and equipment.
- It helps in arranging for finance and due to proper construction management, there is financial and overall control on the work.
- Due to proper construction management, project can be completed in estimated completion cost and time.

#### IV. Functions of Construction Management

1. Project is divided into different phases.
2. Planning and preparing construction schedule.
3. Estimating requirements of material and labour.
4. Procurement of material plant, machinery and employing labours.
5. Arranging for finance and payment of material, and salaries of labours.
6. To establish communication between various sections.
7. To have overall control which includes financial control of the project and to maintain quality and workmanship.

#### 1.1.5 Structural Engineering

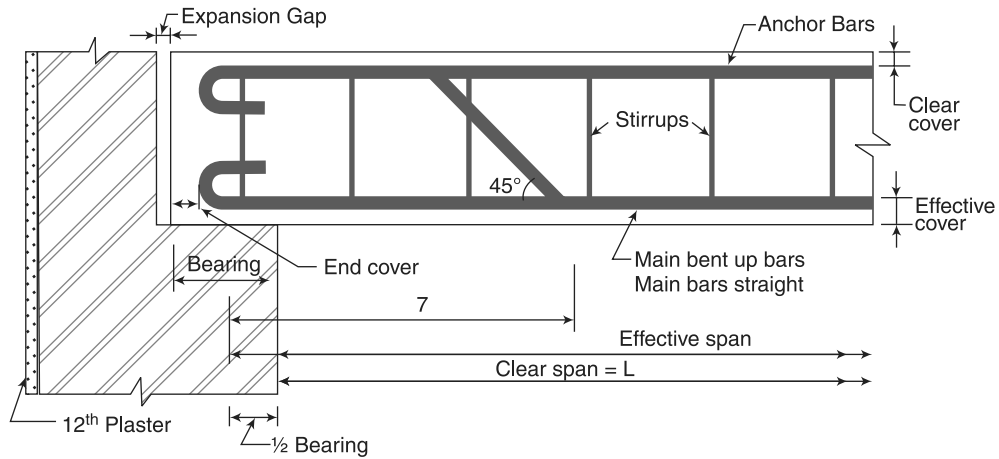
This branch of civil engineering deals with structural analysis and design of structures.



**Fig 1.3** Reinforced Concrete Structures – Footings and Columns

The object of structural analysis is to determine the internal forces and the corresponding displacements of all structural elements as well as those of the entire structural system. The safety and proper functioning of the structure can be ensured only through a thorough structural analysis.

Structural engineering theory is based upon applied physical laws and empirical knowledge of the structural performance of different materials and geometries. Structural engineering design utilizes a number of relatively simple structural elements to build complex structural systems.



**Fig 1.4** Reinforced Concrete Structures – Beams

The aspects of analysis and design are as follows:

- Structural analysis is done to calculate stresses in structural components, on the basis of loads acting on structures.
- Before building a structure, it should be analyzed and designed to decide about its size to resist the possible forces coming on it.
- The structure should be safe and at the same time its components should be as small as possible.
- Requirement of large column free structures gave rise to analysis and design of shell roofs (curved surfaces), geodetic towers and tension structures.
- Up to mid-1960s, lot of improvements were seen in the classical methods of analysis. Need of tall structures and improvements in computers gave rise to matrix method and finite element method of analysis.

The role of structural engineers is as follows:

- Structural engineers are trained to understand, predict, and calculate the stability, strength and rigidity of built structures for buildings and nonbuilding structures.
- Develop designs and integrate their design with that of other designers, and supervise construction of projects on site.
- A structural engineer has to not only give a safe structure but he has to give an economical structure also. Hence, there is need for studying mathematical optimization techniques.
- Structural engineers are responsible for making creative and efficient use of funds, structural elements and materials to achieve these goals.
- Disasters due to earthquakes have made civil engineers to study earthquake forces and build earthquake resistant structures. It needs the knowledge of structural dynamics.

- They can also be involved in the design of machinery, medical equipment, and vehicles where structural integrity affects functioning and safety.

### 1.1.6 Geotechnical Engineering

Geotechnical engineering is that field of civil engineering which deals with soil investigation and design of proper foundations of structures.

**1.1.6.1 Soil Investigation** Geotechnical engineering uses principles of soil mechanics and rock mechanics to investigate subsurface conditions and materials. It deals with determination of the relevant physical/mechanical and chemical properties of these materials; evaluates stability of natural slopes and man-made soil deposits; assesses risks posed by site conditions.

Soil investigation includes collection and testing of soil samples. Soils are considered as three-phase materials composed of rock or mineral particles, water and air. The voids of soil, the spaces in between mineral particles, contain water and air. The engineering properties of soils are affected by four main factors: the predominant size of the mineral particles, the type of mineral particles, the grain size distribution, and the relative quantities of mineral, water and air present in the soil matrix. Fine particles (fines) are defined as particles less than 0.075 mm in diameter.

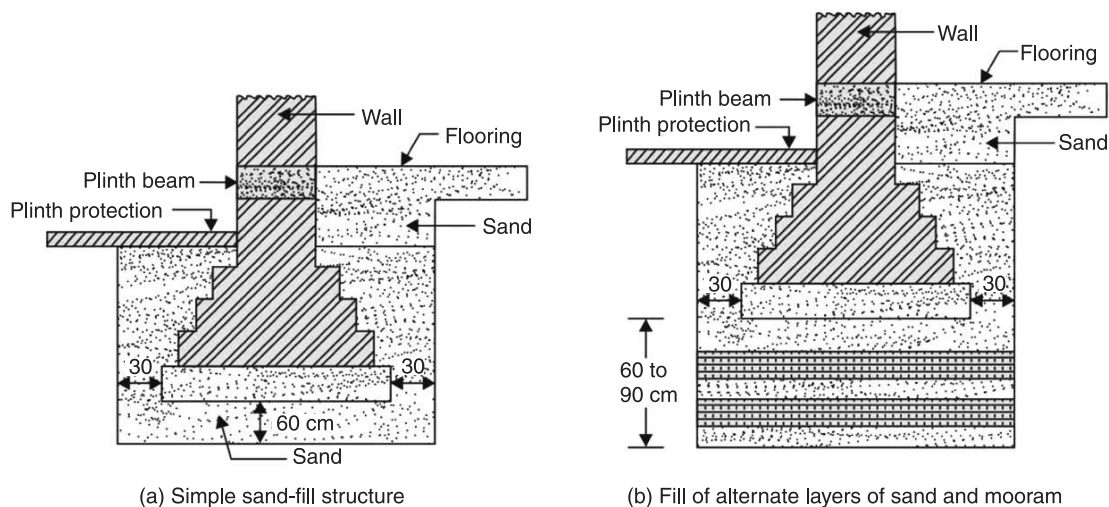
All structures have to finally transfer the load acting on them to soil safely. Soil property changes from place to place. Even in the same place it may not be uniform at different depth and in different seasons. Hence, a civil engineer has to properly investigate soil and decide about the safe load that can be spread on the soil. Geotechnical engineering includes measurement of soil parameters and safe bearing capacity.

**1.1.6.2 Foundation Design** Foundations built for above-ground structures include shallow and deep foundations. Retaining structures include earth-filled dams and retaining walls. Apart from finding safe bearing capacity for foundation of buildings, geotechnical engineering involves various studies required for the design of pavements, tunnels, earthen dam, canals and earth retaining structures. It involves study of ground improvement techniques also. It also includes construction and design of simple foundations, pile foundations, well foundations, caissons, coffer dams, construction of foundation of dams, construction of tunnels, sub base of road, earthen dams, and earth related constructions.

Sound knowledge of geology and geotechnical engineering is necessary for construction of earth related structures. Earthworks include embankments, tunnels, dikes and levees, channels, reservoirs, deposition of hazardous waste and sanitary landfills.

Geotechnical engineering is also related to coastal and ocean engineering. Coastal engineering can involve the design and construction of wharves, marinas, and jetties. Ocean engineering can involve foundation and anchor systems for offshore structures such as oil platforms.

The fields of geotechnical engineering and engineering geology are closely related, and have large areas of overlap. However, the field of geotechnical engineering is a specialty of engineering, whereas the field of engineering geology is a specialty of geology.



**Fig 1.5** Cross Section of Foundation

Geotechnical engineering is important in civil engineering, but it also has applications in military, mining, petroleum and other engineering disciplines that are concerned with construction occurring on the surface or within the ground.

### 1.1.7 Hydraulics, Water Resources and Irrigation Engineering

Water is an important need for all living beings. Study of mechanics of water and its flow characteristics is another important field in civil engineering and it is known as hydraulics. Requirement of water in cities for domestic purpose and for industries is continuously increasing.

Water resource engineering means measurement, utilization and development of water resources for agriculture, municipal and power generation purpose. Rural areas need water for agricultural field also. Hence, civil engineers have to look for new water resources and for storing them. It involves the design of new systems and equipment that help manage human water resources. Water resource engineering deals with planning, designing and developing water resources by constructing several hydraulic structures like dams, barrages, hydropower stations, canal and pipe networks, etc.

Water stored in reservoirs by building bunds and dams should be brought to agricultural fields through canals and distributories. Study connected with this aspect is known as irrigation engineering. It also includes watershed planning, water harvesting techniques, soil conservation and soil reclamation. Hydrology is also a part of water resource engineering. It includes study of sources of water, measurement of rainfall, study of rainfall, runoff, and flood control.



### 1.1.8 Water Supply and Sanitary Engineering

When water is required for drinking purpose, it should be purified and made potable. Purification of water and the technology involved in taking it to the houses is known as water supply engineering. Waste water and solid waste should be treated and disposed so that they do not create health hazard. This branch of civil engineering is known as sanitary engineering.

The five essential requirements for human existence are air, water, food, heat and light. Contamination of these elements may cause serious health hazard not only to man but also to animal and plant life. The use of water by man, plants and animals is universal. Without it, there can be no life. Every living thing requires water.

Man and animals not only consume water, but they also consume vegetation for their food. Vegetation, in turn, cannot grow without water. Growth of vegetation also depends upon bacterial action, while bacteria need water in order to thrive. The bacterial action can convert vegetable matter into productive soil. New plants, which grow in this soil, grow by sucking nutrients through their roots in the form of solution in water. Thus, an ecological chain is maintained. Water maintains an ecological balance, i.e., balance in the relationship between living things and environment in which they live.

The use of water is increasing rapidly with our growing population. Already there are acute shortages of both surface and underground waters in many parts of the country. Careless pollution and contamination of the streams, lakes, reservoirs, wells and other underground sources has greatly impaired the quality of available water. This pollution results because of improper disposal of waste water – both domestic as well as industrial. Organized community life requires twin services of water supply and sewage disposal.

Good sanitation cannot be maintained without adequate water supply system. Without proper disposal, the wastes of a community can create intolerable nuisance, spread diseases and create other health hazards. The planning, designing, financing and operation of water and waste water systems are complex undertakings, and they require a high degree of skill and judgement.

**1.1.8.1 Need for Protected Water Supplies** It is necessary that the water which is supplied to the public must be invariably free from all types of impurities both suspended and/or dissolved in it, any kind of bacteria and any other contamination which may cause serious harm to the health of the public. It is therefore imperative to plan and build such a water supply scheme which would provide potable water free from any kind of contamination.

In general, the water obtained from wells or springs, i.e., groundwater, is free from impurities and it may be supplied to public without adopting any method of purification. This is so because, in the course of its movement through the porous sub-strata, the water is completely relieved of its suspended impurities. However, before supplying to the public this water may have to be disinfected by chlorination (i.e., by adding chlorine or chlorine compound to water) or any other methods, in order to remove any harmful bacteria responsible for causing diseases.



The Water obtained from any of the surface source needs to be purified before it can be supplied to the public. The most commonly adopted method of purification of water is filtration. In the process of filtration, water is allowed to pass through sand beds and gravel whereby minute suspended and dissolved particles are removed. It has been found that the process of filtration is greatly accelerated if water is pretreated with certain substances, which when added to water forms large masses of precipitates or flocs out of the impurities present which in the process settle down and are ultimately removed. This prefiltration treatment of water is known as coagulation which involves the use of alum.

The water having undergone through the process of filtration is still found to contain some harmful disease producing bacteria which are minutely-sized living organisms not visible to naked eye. As such in order to ensure protected supplies of water free from any health hazard, it is necessary to kill these bacteria by disinfecting water. The most commonly adopted method of disinfecting is chlorination which is a process of adding chlorine or chlorine compound to water. Other methods of disinfecting water viz., treatments through ozone or ultraviolet rays or excess lime are also in use.

Thus, it may be seen that a public water supply system should be such that it is able to provide an adequate and reliable supply of water catering to all the public needs and also ensure that the supplies so made are not only potable but also fully protected against any inflection which might pollute water and cause epidemics resulting in human suffering and loss.

**1.1.8.2 Objectives of Public Water Supply System** The main objectives of any public water supply system are as follows:

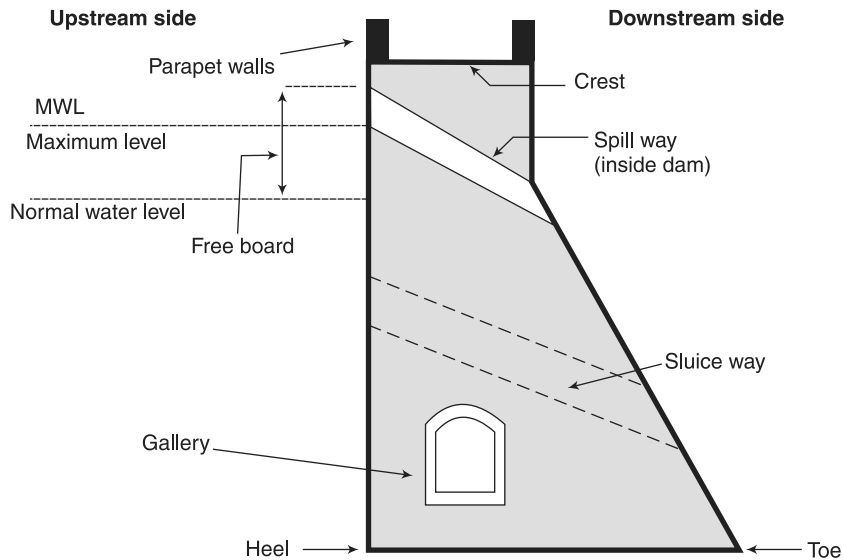
- To supply safe and wholesome water to the consumers
- To supply water in adequate quantity
- To make water available within easy reach of the consumers so as to encourage the general cleanliness.

**1.1.8.3 Planning of Water Supply Scheme for A Town or City** In planning a water supply scheme for a town or city the following points need to be considered:

- Sources of water
- Quality of water
- Population
- Rate of consumption
- Topography of area
- Financial aspects
- Trends of future development

**1.1.8.4 Sources of Water** The various sources of water available on the earth can be classified into the following two categories:

1. Surface sources of water
2. Sub-surface or underground sources of water



**Fig 1.6** Cross Section of Storage Reservoir

**1. Surface sources of water** These are those sources of water which are available at the ground surface. The various sources of water included in this category are as follows:

- (a) Lakes and Ponds
- (b) Streams or rivers
- (c) Storage reservoirs
- (d) Oceans

(a) **Lakes and Ponds** A large natural depression or hollow formed in the earth's surface, which gets filled with water is called a lake. The surface runoff from the catchment area contributing to a lake enters the lake through small natural streams. The groundwater may also enter a lake through springs.

The quantity of water available from a lake depends upon its size, catchment area, annual rainfall and geological formations. The quality of water available from a lake mainly depends upon the characteristics of its catchment. Thus water in a lake would be relatively pure and of good quality if it draws water from uninhabited upland hilly areas free from soluble salts. On the other hand the water in a lake would be contaminated if it draws from low land areas containing large quantities of soluble salts and other impurities. Moreover, a small lake containing still water may have plenty of algae, weed and other vegetable growth imparting bad smell, taste and colour to the water.

Thus, if a sufficient quantity of good quality water is available from a lake then it will be a very useful source of water supply from which water may be supplied without any treatment or with some preliminary treatment. However, if the water

in the lake is of relatively poor quality then it should be properly analyzed and treated before supplying to the public.

A pond is a man-made body of standing water smaller than a lake. The ponds are formed by digging of ground and they are filled up with water in rainy season. The quantity of water in a pond is generally very small and often it contains many impurities. As such pond water is generally not suitable for drinking purposes and it can be used only for bathing, washing of clothes or for animals.

- (b) **Streams or Rivers** A stream or river is a natural channel which carries surface runoff received by it from its catchment or drainage basin. It also carries the groundwater flow added to it and the runoff resulting from the melted snow. Rivers are the most important sources of water supply. It is a well-known fact that several big and important cities of the world are situated on the banks of important rivers. Some of the examples in our country are the cities such as Delhi, Calcutta, Ahmedabad, etc. This is due to the availability of large quantity of the water from rivers for water supply throughout the year.

The rivers may be either perennial or non-perennial. Perennial rivers are those in which water is available throughout the year. Such rivers are fed by rains during the rainy season and by melting of snow during the summer season. On the other hand, non-perennial rivers are those in which water is not available throughout the year. Generally, from perennial rivers, water may be utilized directly for public supplies without any arrangement for storage of water. However, if during dry weather periods, the flow in the river is considerably reduced, either the arrangement for raising the water level in the river or the arrangement for storage of water will have to be made to ensure the supply of water in the required quantity. This may be achieved either by constructing a weir or barrage, or by constructing a dam and creating a storage reservoir. Evidently, non-perennial rivers can be used for water supply only by providing necessary storage arrangements.

Close to the point of origin in the mountains, the river water is fairly pure but as the river approaches plains, the quality of its water deteriorates considerably, because it picks up lot of suspended matter, clay, silt, etc., and becomes muddy appearances. Further, the disposal of the untreated or ever treated sewage into the river is liable to contaminate the river water. As such the river water must be properly analyzed and treated before supplying to the public.

- (c) **Storage reservoirs** The flow rate of a river or natural stream may vary considerably during different periods of the year. It may carry little or no water during dry weather periods and may carry huge amount of water during rainy season. Thus, if water is drawn directly from a river then during extremely low flows it may not be possible to meet the demands of the consumers, while during high flows there may be operational problems. As such it is essential to create a storage reservoir or an artificial lake by constructing a dam across the river, which can store excess water that flows in the river during the periods of high flows, for use during the periods of low flows or draughts.

The quality of water in a storage reservoir mainly depends on the quality of the water flowing in the river on which the reservoir is created. As such the water from a storage reservoir also needs to be properly analyzed and treated before supplying to the public.

The storage reservoirs are the main sources of water supply for big cities. However, the storage reservoirs are created not only for water supply but also for other purposes such as irrigation, hydropower generation, navigation, flood control, etc. A storage reservoir for supplying water for more than one purpose is termed as multipurpose reservoir.

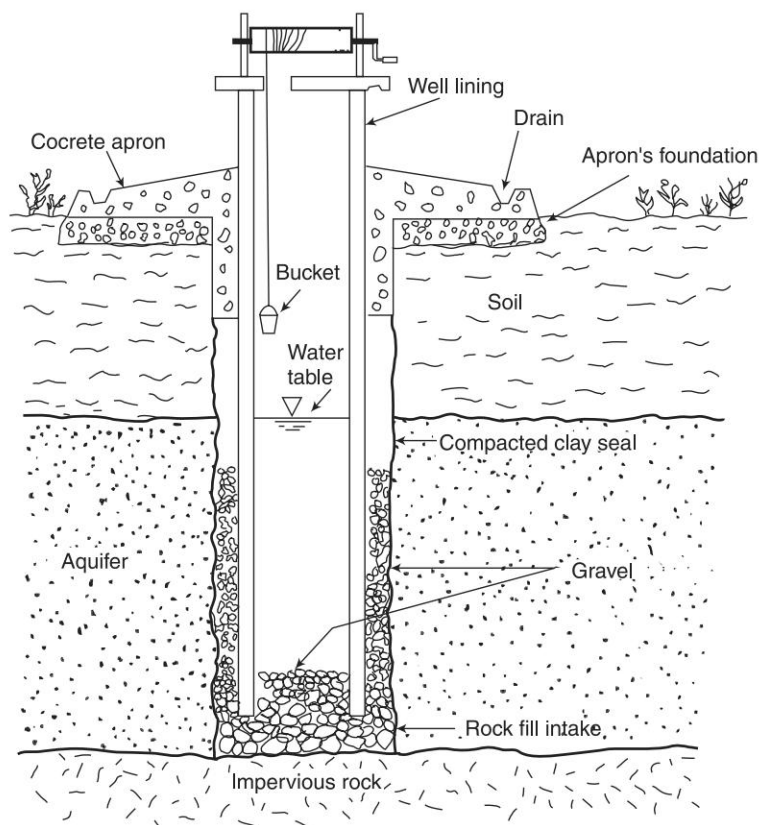
- (d) Oceans Oceans carry huge amount of water which is estimated to be about 94 to 97 percent of the total quantity of water available on our planet Earth. However, the ocean water being highly saline cannot be used for water supply unless the excessive salt content of the water is removed. The process of removing salt from water is known as desalination and the salt free water so obtained is known as fresh water. As indicated, several methods of desalination have been developed later for the conversion of salt into fresh water. However, because of the tremendous cost involved, the procurement of fresh water for water supply by desalination of ocean water has not become common.

**2. Sub-Surface or Underground sources of water** The underground (or sub surface) sources of water are of the following four forms.

- (a) Infiltration galleries
- (b) Infiltration wells
- (c) Springs
- (d) Wells

From each of the first three forms, relatively small quantity of groundwater is obtained and hence, these may be considered as the minor forms of underground sources of water. On the other hand, most of the groundwater is extracted from the last form viz., wells, and hence it is a major form of underground source of water.

- (a) Infiltration galleries. An infiltration gallery is horizontal or nearly horizontal tunnel usually rectangular in cross-section having permeable boundaries so that groundwater can infiltrate into the same, and hence it is also sometimes known as horizontal well. It is generally provided in highly permeable aquifers with high water table so that adequate head is available for gravity flow of groundwater into the gallery. It is frequently located near a perennial recharge source and hence, it is usually placed along the bank or under the bed of river. The usual depth at which the gallery is placed ranges from 3 to 10 m below the ground surface.



**Fig 1.7** Cross Section of Infiltration Gallery

- (b) Infiltration wells. Infiltration wells are the shallow wells constructed in series along the banks of river to collect the water seeping through the banks of the river. The wells are closed at top and open at bottom. These wells are constructed of brick masonry with open joints. For the purpose of inspection, manhole is provided in the top cover of the well. The water infiltrates through the bottom of these wells and as it has to pass through sand bed it gets purified to some extent.

The various infiltration wells are connected by porous pipes to a collecting sump well known as jack well. The water collected in the infiltration wells flows by gravity into the jack well. The water from the jack well is pumped to treatment plant and supplied to the consumers.

- (c) Springs. A spring is natural outflow of groundwater which appears at the ground surface as a current or stream of flowing water. Springs may be classified into (i) those resulting from gravitational forces, and (ii) those resulting from non-gravitational forces.

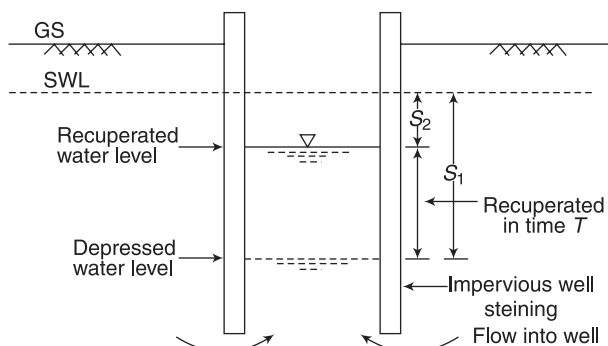
(i) **Gravity springs** results from water flowing under hydrostatic pressure. The following are the different types of gravity springs.

- (a) **Depression springs.** These springs are formed due to overflowing of the water table, where the ground intersects the water table. The flow from such a spring is variable with the rise or fall of water table and hence in order to meet with such fluctuations, a deep trench may be constructed near such a spring. The deeper is the trench, the greater is the certainty of continuous flow because the saturated ground above the elevation of the trench bottom will act as a storage reservoir to compensate for the fluctuations of the water table.
- (b) **Contact springs of surface springs.** These springs are created by a permeable water bearing formation overlying a less permeable or impermeable formation that intersects the ground surface. However, in such springs, because of the relatively small amount of underground storage available above the elevation of the overflow crest, the flow from them is uncertain and is likely to cease after a drought. As such, these springs can also be developed by the construction of a cutoff trench or a cutoff wall.
- (c) **Artesian springs.** These springs result from release of water under pressure from confined aquifers either at an outcrop of the aquifer or through an opening in the confining bed. The amount of water available in an artesian spring may be large if the catchment area is large. The flow may be slightly increased by the removal of obstructions from the mouth of the spring.
- (ii) **Non-gravity springs** include volcanic springs and fissure springs. The volcanic springs are associated with volcanic rocks and the fissure springs result from fractures extending to great depths in the earth's crust these are usually thermal springs. Thermal springs discharge water having a temperature in excess of the normal local groundwater. These are also designated as warm springs and hot springs. Waters of thermal springs are usually highly mineralized and often contain sulphur.

In general springs are capable of supplying small quantity of water and hence these may serve as sources of water supply only for small towns, especially near hills or bases of hills. Further the hot springs cannot be used to supply water for domestic purposes. However, the water obtained from some of the hot springs is found to be useful for the cure of certain skin diseases.

- (d) **Wells** A water well is a hole or shaft, usually vertical, excavated in the groundwater to the surface. Water wells may be classified as
  - (i) Open wells or dug wells
  - (ii) Tube wells
  - (i) **Open wells or Dug wells:** Open wells are the wells which have comparatively large diameters but low yields (or discharge) and are not very deep. The diameters of the open wells usually vary from 1 m to 10 m. The yield of such wells in most of the cases is about  $20 \text{ m}^3/\text{hour}$  or less. However, a properly constructed open well penetrating a permeable aquifer can yield 100 to  $300 \text{ m}^3/\text{hour}$ . The depths

of open wells may generally range from 2 m to 20 m. Since these wells are usually constructed by digging, these are also known as dug wells. The walls of an open well may be built of brick or stone masonry or precast concrete rings. The thickness generally varies from 0.5 m to 0.75 m depending on the depth of the well.



**Fig 1.8** Cross Section of Open Well

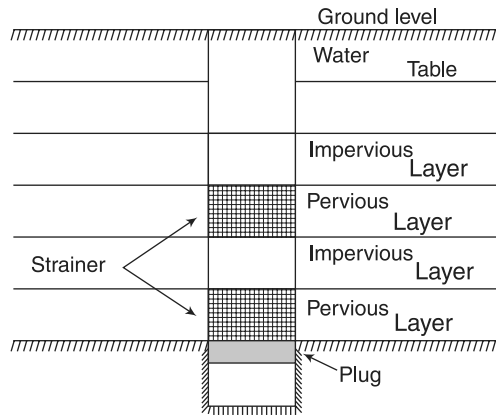
Open wells may be further classified as:

- (a) Shallow open wells
- (b) Deep open wells

Shallow open wells are those which rest in the top water bearing strata and draw their supplies from the surrounding material. On the other hand, deep open wells are those which rest on impervious strata and draw their supplies from the previous formation lying below the impervious strata through bore holes made in the impervious strata. The impervious strata is generally known as *mota* layer and it is a layer of clay, cemented sand, *kankar* or other hard materials. The term *mota* layer is however not applied to layers of hard materials laying above the water table. The main advantage of such a *mota* layer is that it gives structural support to the open well resting on its surface. Further, since the previous formations below the *mota* layer generally contain large quantity of water. The yield of deep wells is more than that of shallow wells. It may, however, be mentioned that the nomenclature of shallow and deep open wells is purely technical and it has nothing to do with the actual depth of the well because sometimes a shallow well may have more depth than a deep well.

- (ii) **Tube wells.** A tube well is along pipe sunk into the ground intercepting one or more water bearing strata. As compared to open wells, the diameters of tube wells are much less and usually range from 80 mm to 600 mm. The tube wells can also be further classified as:
  - (a) Shallow tube wells
  - (b) Deep tube wells





**Fig 1.9** Cross Section of Tube Well

Shallow tube wells have their depths limited to about 30 m and may have a maximum yield of about  $20 \text{ m}^3/\text{hour}$ . On the other hand, deep tube wells may have maximum depth of about 600 m yield more than  $800 \text{ m}^3/\text{hour}$ .

The tube wells may also be classified as:

- (a) Strainer type tube well
- (b) Cavity type tube well
- (c) Slotted type tube well

Some of the common types of strainers used for the tube wells are as follows:

- (a) Cook strainer
- (b) Tej strainer
- (c) Brownlie strainer
- (d) Ashford strainer
- (e) Leggett strainer
- (f) Phoenix strainer
- (g) Layne and Bowler strainer

#### 1.1.8.5 Quality of Water

The water required for public water supply schemes should be potable or wholesome water that is fit for drinking purposes. The potable water or wholesome water with relation to various uses of water are discussed below.

**1. Domestic use** The water required for domestic consumption should possess a high degree of purity and it should be free from suspended impurities, bacteria etc. A tolerance of small degree of hardness developed due to certain dissolved salts is however permissible. Thus the drinking water and water used in the food industry and some other industries must meet the highest standard of purity.

Following are the requirements of potable or wholesome water for domestic use.

1. It should be clear, odourless and colourless



2. It should be free from harmful and disease producing bacteria
3. It should be free from all objectionable substances
4. It should be fresh and cool
5. It should be palatable that is aesthetically attractive
6. It should be tasty
7. It should not cause corrosion to the pipes and other fittings

**2. Civic use** For this purpose, a large quantity of water is required to fulfill various civic purposes such as washing of roads, cleaning of sewers etc. The nature of use of water is such that any degree of impurity can be tolerated. Hence, the water containing large amount of suspended and dissolved impurities may be permitted for this purpose. But the water considerably mixed up with sewage and other refuse cannot be tolerated for this purpose.

**3. Trade or business use** The water required for a particular trade will depend upon nature of that trade. For instance, the water required for laundry should not be hard as it will result in more consumption of soap. Similarly the water required for bathing cattles and washing floors in case of stables may contain any type of impurities.

**4. Commercial or industrial use** The water required for this purpose should be chemically pure. The various chemical processes involved in the production make it essential to use chemically pure water. A slight amount of impurity may considerably affect the final results of the product.

**1.1.8.5.1 Analysis of water** In order to ascertain the quality of water, it is subjected to the various tests. These test can be divided into the following three categories.

1. Physical test
2. Chemical test
3. Bacteriological tests

**1. Physical tests** Under this category, the tests are carried out to examine water for the following:

- (a) Colour
- (b) Taste and odour
- (c) Temperature
- (d) Turbidity

Other physical characteristics for which tests are sometimes carried out are density, electrical conductivity, radioactivity and viscosity.

- (a) Colour The pure waster is colourless and following are the sources which contribute colour to the water.
  - Algae metabolism
  - End products of degraded organic matter
  - Discharge of untreated and partially treated waste water from various industries like food processing, textile industry tanneries, paper production etc.
  - Divalent species containing iron and manganese etc.

- (b) **Taste and odour** The water possess taste and odour due to various causes and they make the water unpleasant for drinking. The taste and odour of water may also be tested by threshold number. In this method, the water to be tested is diluted with odour-free water and mixture at which odour becomes detectable is determined. It indicates threshold number and other intensities of odour are then worked out. For public water supply, the threshold number not more than 3.
- (c) **Temperature** The test for temperature of water has no practical meaning in the sense that it is not possible to give any treatment to control the temperature in any water supply project. The measurement of temperature of water is done with the help of ordinary thermometers. The desirable temperature of potable water is 10°C while temperature of 25°C is considered to be objectionable.
- (d) **Turbidity** The colloidal matter present in water interferes with passage of light and thus imparts turbidity to the water. The turbidity is expressed in terms of parts of suspended matter per million parts of water or shortly written as p.p.m. The permissible turbidity for drinking water is 5 to 10 p.p.m. The measurement of turbidity in the field is done by means of a turbidity rod and it is referred to as the visual method of turbidity measurement. For laboratory, the various instruments known as the Jackson turbidimeter, Baylis turbidimeter and Nephelometric turbidimeter.

**2. Chemical Test** Under this category, the tests are carried out to examine water for the following:

- (a) Chlorides
  - (b) Dissolved gases
  - (c) Hardness
  - (d) Hydrogen-ion Concentration (pH Value)
  - (e) Alkalinity
  - (f) Acidity
  - (g) Metals and other chemical substances
  - (h) Nitrogen and its compounds
  - (i) Total solids
- (a) **Chlorides** The chloride contents, especially of sodium chloride or salt, are worked out for a sample of water. The measurement of chloride contents is carried out by the titration method. For potable water, the highest desirable level of chloride content is 250 mg/litre and its maximum permissible level is 600 mg/litre.
  - (b) **Dissolved gas** The water contains various gases from its contact with the atmosphere and ground surfaces. The usual gases are nitrogen, methane, hydrogen sulphide, carbon dioxide and oxygen. The contents of these dissolved gases in a sample of water are suitably worked out. The quantity of oxygen for potable water should be 5 to 10 ppm.
  - (c) **Hardness** The term hardness is defined as the ability of the water to cause precipitation of insoluble calcium and magnesium salts of higher fatty acids from soap. The hardness

is usually measured by the soap solution test. For potable water, the hardness should preferably be more than 5 degrees but less than 8 degrees or so.

- (d) Hydrogen-ion Concentration (pH Value) The acidity or alkalinity of water is measured in terms of pH value or H-ion concentration. Two methods are employed to measure the pH value of water. One is electrometric method and colourimetric method. It is desirable to maintain pH value of water very close to 7.
- (e) Alkalinity The term alkalinity with reference to the water and waste water is defined as the capacity of substances contained in the water to take up hydronium to reach a defined pH value 4.3 to 14. The alkalinity of a sample can be determined by the process of titration.
- (f) Acidity The term acidity with reference to the water and waste water is defined as the capacity of substances contained in the water to take up hydroxyl ions to reach a defined pH value 0 to 8.2.
- (g) Metals and other chemical substances The various tests are made to detect the presence of different metals and other chemical substances in a sample of water. Table gives the maximum concentration of metals and other chemical substances in potable water as recommended by U.S Public Health Service standards.

**Concentration of metals and other Chemical Substances in Potable water**

S. No.	Name of metal	Maximum permissible concentration in mg/litre
1	Alkyl Benzene Suphonate .....(ABS)	0.50
2	Arsenic..... (As)	0.05
3	Barium..... (Ba)	1
4	Cadium.....(Cd)	0.01
5	CarbonChloroform Extract..... (CCE)	0.20
6	Copper.....(Cu)	1
7	Cyanide.....(CN)	0.20
8	Fluoride.....(F)	1.70
9	Hexavalent chromium	0.05
10	Iron.....(Fe)	0.30
11	Lead.....(Pb)	0.05
12	Manganese.....(Mn)	0.05
13	Phenols	0.001
14	Selenium.....(Se)	0.01
15	Silver.....(Ag)	0.05
16	Sulphate.....(SO <sub>4</sub> )	250
17	Zinc.....(Zn)	5.00

- (h) Nitrogen and its compounds: The nitrogen is present in water in the following four forms
- Free ammonia
  - Albuminoid ammonia
  - Nitrites
  - Nitrates

The amount of free ammonia in potable water should not exceed 0.15 p.p.m and the albuminoid ammonia should not exceed 0.3 p.p.m. The amount of nitrites in potable water should be nil. For potable water the highest desirable level of nitrates is 45 mg per litre.

- (i) Total solids: The term solid with reference to the environmental engineering is defined as the residue in water left after evaporation and drying in oven at 103°C to 105°C. The total solids consist dissolved and suspended matter. The permissible total dissolved solids for drinking water to BIS is 500 mg/l with tolerable limit as 1500 mg/l.

**3. Bacteriological Tests** The examination of water for the presence of bacteria is very important. The bacteria are very small organisms and it is not possible to detect them by microscopes. Hence they are detected by circumstantial evidences or chemical reactions.

Two standard Bacteriological Tests for the bacteriological examinations of water.

- (a) Total count or Agar plate count test
- (b) B-coli test
- (a) Total count or Agar plate count test: In this test, the bacteria are cultivated on specially prepared medium of agar for different dilutions of sample of water with sterilized water. The diluted sample is placed in an incubator for 24 hours at 37 C or for 48 hours at 20 C. These represent the so-called hot counts and cold counts respectively. The bacterial colonies which are formed, are then counted and the results are computed for 1 cc. For potable water, the total count should not exceed 100 per c.c.
- (b) B-coli test: This test is divided into the following three parts
- Presumptive test
  - Confirmed test
  - Completed test

The presumptive test is based on the ability of coliform group to ferment the lactose broth and producing gas. The confirmed test consists of growing cultures of coliform bacteria on media which suppress the growth of other organisms. The completed test is based on the ability of the culture grown in the confirmed test to again the lactose broth.

**B-coli index:** This is an index or number which represents approximately the number of B-coli per c.c of sample of water under consideration. For potable water,

the b-coli index should be preferably less than 3 and it should not exceed 10 in any event.

The Physical and Chemical Quality of Water Standards Prepared by The Central Public Health and Environmental Engineering Organisation, Under the Ministry of Urban Development (MUD) India is Given Below:

#### PHYSICAL AND CHEMICAL STANDARDS (MUD, INDIA)

S. No. (1)	Characteristics (2)	Acceptable* (3)	Cause for ** rejection (4)
1	Turbidity (units on J.T.U. scale)	2.5	10
2	Colour (units of platinum cobalt scale) Taste and odour	5.0	2.5
3	pH	unobjectionable	unobjectionable
4	Total dissolved solids (mg/1)	7.0 to 8.5	6.5 to 9.2
5	Total hardness (as CaCO <sub>3</sub> ) (mg/1)	500	1500
6	Chloride (as Cl) (mg/1)	200	600
7	Sulphates (as SO <sub>4</sub> ) (mg/1)	200	1000
8	Fluorides (as F) (mg/1)	200	400
9	Nitrates (as NO <sub>3</sub> ) (mg/1)	1.0	1.5
10	Calcium (as Ca) (mg/1)	45	45
11	Magnesium (as Mg) (mg/1)	75	200
12	Iron (as Fe) (mg/1)	>30***	150
13	Manganese (as Mn) (mg/1)	0.1	1.0
14	Copper (as Cu) (mg/1)	0.05	0.5
15	Zinc (as Zn) (mg/1)	0.05	1.5
16	Phenolic compounds (as phenol) (mg/1)	5.0	15.0
17	Anionic detergents (as MBAS) (mg/1)	0.001	0.002
18	Mineral oil (mg/1)	0.2	1.0
19	Toxic Materials – Arsenic (as As) mg/1	0.01	0.3
20	Cadmium (as Cd) mg/1	0.05	0.05
21	Chromium (as hexavalent Cr) mg/1	0.01	0.01
22	Cynides (as CN) mg/1	0.05	0.05
23	Lead (as Pb) mg/1	0.05	0.05
24	Selenium (as Se) mg/1	0.1	0.1
25	Mercury (total Hg) mg/1	0.01	0.01
26	Polynuclear aromatic	0.001	0.001
27	Hydrocarbons (PAH) mg/1		
	<b>Radio activity</b> Gross Alpha activity	0.2 µg/1	0.2 µg/1
28	Gross Beta activity	3 pci/1	3 pci/1
29	pCi = pico Curie	30 pci/1	30 pci/1

**1.1.8.6 Rainwater Harvesting** In the present scenario, management and distribution of water has become centralized. Living creatures of the universe are made of five basic elements, viz., Earth, Water, Fire, Air and Sky. Obviously, water is one of the main resource, without which, it is not possible for us to sustain our lives. A country's level of water use is one of the key measure of its level of economic development. Developing countries like India uses 90 percent of its water for agricultural purpose, just 7 percent for industry and hardly 3 percent for domestic use.

Despite having a great regard for water, we seem to have failed to address this sector seriously. Human being could not save and conserve water and its sources, probably because of its availability in abundance. But this irresponsible attitude resulted in deterioration of water bodies with respect to quantity and quality both. Now, situation has arrived when even a single drop of water matters. However, "better late than never", we have not realized the seriousness of this issue and initiated efforts to overcome these problems. System of collection of rainwater and conserving for future needs has traditionally been practiced in India. The Government of Tamil Nadu passed a Government Order (GO) to implement the Rainwater harvesting as compulsory in the state. This scheme was highly appreciated by the Government of India in the parliament house. Now-a-days, many states are following this scheme and ultimately they found the benefits.

The term rainwater harvesting is being frequently used these days; however, the concept of water harvesting is not new for India. Water harvesting techniques had been evolved and developed centuries ago. Groundwater resource gets naturally recharged through percolation. But due to indiscriminate development and rapid urbanization, exposed surface for soil has been reduced drastically with resultant reduction in percolation of rainwater, thereby depleting groundwater resource. Rainwater harvesting is the process of augmenting the natural filtration of rainwater into the underground formation by some artificial methods. "Conscious collection and storage of rainwater to cater to the demands of water, for drinking, domestic purpose and irrigation is termed as Rainwater Harvesting."

### ***I. Objectives of Rainwater Harvesting***

- To provide water for domestic purposes
- To increase water resource
- To reduce water scarcity
- To arrest groundwater decline and augment groundwater table
- To beneficiate water quality in aquifers
- To conserve surface water runoff during monsoon
- To reduce soil erosion and run-off losses
- To inculcate a culture of water conservation

### ***II. Methods of Rainwater Harvesting***

Rainwater can be harvested by any one of the following methods after analyzing the soil characteristics, topography, rainfall pattern and the climatic conditions.

- By storing in vessels, tanks and reservoirs above or below the ground
- By constructing pits, lagoons, dug wells or check dams, etc.
- By recharging the groundwater.

Broadly, there are two ways of harvesting Rainwater:

- (i) Surface runoff harvesting
- (ii) Rooftop rainwater harvesting

**(i) Surface runoff harvesting** In urban areas, rainwater flows away as surface runoff. This runoff could be caught and used for recharging aquifers by adopting appropriate methods.

**(ii) Rooftop rainwater harvesting (RTRWH)** It is a system of catching rainwater where it falls. In rooftop harvesting, the roof becomes the catchments and the rainwater is collected from the roof of the house/building. It can either be stored in a tank or diverted to artificial recharge system. This method is less expensive and very effective and if implemented properly, helps in augmenting the groundwater level of the area.



**Fig. 1.10** Rooftop rainwater harvesting

### **III. Components of the Rooftop Rainwater Harvesting System**

The system mainly constitutes of the following sub components:

**(i) Catchment** The surface that receives rainfall directly is the catchment of rainwater harvesting system. It may be terrace, courtyard, or paved or unpaved open ground. The terrace may be flat RCC/stone roof or sloping roof. Therefore, the catchment is the area, which actually contributes rainwater to the harvesting system.

**(ii) Transportation** Rainwater from rooftop should be carried through down take water pipes or drains to storage/harvesting system. Water pipes should be UV resistant (ISI



HDPE/PVC - High-density polyethylene, Polyvinyl chloride - pipes) of required capacity. Water from sloping roofs could be caught through gutters and down take pipe. At terraces, mouth of the each drain should have wire mesh to restrict floating material.

**(iii) First Flush** First flush is a device used to flush off the water received in first shower. The first shower of rains needs to be flushed-off to avoid contaminating storable/rechargeable water by the probable contaminants of the atmosphere and the catchment roof. It will also help in cleaning of silt and other material deposited on roof during dry seasons. Provisions of first rain separator should be made at outlet of each drain pipe.

**(iv) Filter** There is always some skepticism regarding roof top rainwater harvesting, since doubts are raised that rainwater may contaminate groundwater. There is remote possibility of this fear coming true if proper filter mechanism is not adopted. Secondly, all care must be taken to see that underground sewer drains are not punctured and no leakage is taking place in close vicinity. Filters are used for treatment of water to effectively remove turbidity, colour and microorganisms. After first flushing of rainfall, water should pass through filters. There are different types of filters in practice, but basic function is to purify water.

#### **IV. Methods of Roof Top Rainwater Harvesting**

**(i) Storage of Direct Use** In this method, rainwater collected from the roof of the building is diverted to a storage tank. The storage tank has to be designed according to the water requirements, rainfall and catchment availability. Each drain pipe should have mesh filter at mouth and first flush device followed by filtration system before connecting to the storage tank. It is advisable that each tank should have excess water overflow system.

Excess water could be diverted to recharge system. Water from storage tank can be used for secondary purposes such as washing and gardening, etc. This is the most cost effective way of rainwater harvesting. The main advantage of collecting and using the rainwater during rainy season is not only to save water from conventional sources, but also to save energy incurred on transportation and distribution of water at the doorstep. This also conserve groundwater, if it is being extracted to meet the demand when rains are on.

**(ii) Recharging Groundwater Aquifers** Groundwater aquifers can be recharged by various kinds of structures to ensure percolation of rainwater in the ground instead of draining away from the surface. Commonly used recharging methods are:

**(a) Recharging of bore wells** Rainwater collected from rooftop of the building is diverted through drainpipes to settlement or filtration tank. After settlement, filtered water is diverted to bore wells to recharge deep aquifers. Abandoned bore wells can also be used for recharge.

Optimum capacity of settlement tank/filtration tank can be designed on the basis of area of catchment, intensity of rainfall and recharge rate. While recharging, entry of floating matter and silt should be restricted because it may clog the recharge structure. First one or



two showers should be flushed out through rain separator to avoid contamination. This is very important, and all care should be taken to ensure that this has been done.

**(b) Recharge pits** Recharge pits are small pits of any shape rectangular, square or circular, constructed with brick or stone masonry wall with deep hole at regular intervals. The top of pit can be covered with perforated covers. Bottom of pit should be filled with filter media.

The capacity of the pit can be designed on the basis of catchment area, rainfall intensity and recharge rate of soil. Usually, the dimensions of the pit may be of 1 m to 2 m wide and 2 to 3 m deep depending on the depth of pervious strata. These pits are suitable for recharging of shallow aquifers and small houses.

**(c) Soak away or recharge shafts** Soak away or recharge shafts are provided where upper layer of soil is alluvial or less pervious. These are bored hole of 30 cm diameter up to 10 m to 15 m deep, depending on depth of pervious layer. Bore should be lined with slotted/perforated PVC/MS pipe to prevent collapse of the vertical sides. At the top of soak away, required size sump is constructed to retain runoff before the filters through soak away. Sump should be filled with filter media.

**(d) Recharging of dug wells** Dug well can be used as recharge structure. Rainwater from the rooftop is diverted to dug wells after passing it through filtration bed. Cleaning and desalting of dug well should be done regularly to enhance the recharge rate. The filtration method suggested for bore well recharging could be used.

**(e) Recharge Trenches** Recharge trench is provided where upper impervious layer of soil is shallow. It is a trench excavated on the ground and refilled with porous media like pebbles, boulder or brickbats. It is usually made for harvesting the surface runoff. Bore wells can also be provided inside the trench as recharge shafts to enhance percolation. The length of the trench is decided as per the amount of runoff expected. This method is suitable for small houses, playgrounds, parks and roadside drains. The recharge trench can be of size 0.50 to 1.0 m wide and 1.0 to 1.5 m deep.

**(f) Percolation Tanks** Percolation tanks are artificially created surface water bodies, submerging a land area with adequate permeability to facilitate sufficient percolation to recharge the groundwater. These can be built in big campuses where land is available and topography is suitable.

Surface run-off and rooftop water can be diverted to this tank. Water accumulating in the tank percolates in the solid to augment the groundwater. The stored water can be used directly for gardening and raw use. Percolation tanks should be built in gardens, open spaces and roadside green belts of urban area.

#### ***V. Benefits of Rainwater Harvesting***

- Improves the quality of groundwater
- Raises the water levels in wells for future use
- Improves soil moisture

- Low cost expenses with little maintenance
- Helps in recharging the aquifers
- Reduces water scarcity

### 1.1.9 Environmental Engineering

Environmental engineering deals with pollution control and public health engineering. Different types of pollutions are water, air, noise and others. Due to large scale industrialization, population growth, rapid urbanization and several other human activities like construction, mining, transportation, etc., environment gets polluted. Environmental engineering deals with technologies and facilities which are engaged in reducing pollution. It includes design, construction and maintenance of water treatment plant, waste water treatment plant, water distribution network and sewerage system; it also deals with solid waste management in towns and cities. Public health engineering includes water treatment, water distribution network and solid waste management.

Environmental engineering is concerned with the application of scientific and engineering principles for protection of human population from the effects of adverse environmental factors; protection of environments, both local and global, from potentially deleterious effects of natural and human activities; and improvement of environmental quality.

Environmental engineering can also be described as a branch of applied science and technology that addresses the issues of energy preservation, protection of assets and control of waste from human and animal activities. Furthermore, it is concerned with finding possible solutions in the field of public health, such as waterborne diseases, implementing laws which promote adequate sanitation in urban, rural and recreational areas. It involves waste water management, air pollution control, recycling, waste disposal, radiation protection, industrial hygiene, animal agriculture, environmental sustainability, health and environmental engineering law. It also includes studies on the environmental impact of proposed construction projects.

Environmental engineers study the effect of technological advances on the environment. To do so, they conduct studies on hazardous-waste management to evaluate the significance of such hazards, advise on treatment and containment, and develop regulations to prevent mishaps. Environmental engineers design municipal water supply and industrial wastewater treatment systems. They address local and worldwide environmental issues such as the effects of acid rain, global warming, ozone depletion, water pollution and air pollution from automobile exhausts and industrial sources.

Apart from tackling solid and waste water disposal, civil engineers have to tackle air pollution problem also. Due to industrialization air pollution is becoming a major problem. It is estimated that for every tonne of cement produced, one tonne of CO<sub>2</sub> is released in the environment. Vehicles also produce lot of CO<sub>2</sub>. During the last one century, the environmental pollution has resulted in global warming by 4°C.

An environmental disaster will be unavoidable if China, India and other developing countries start consuming as much energy and materials as the West did it in its march to industrialization. Hence, environmental engineering is emerging as an important field of study in civil engineering.

### 1.1.10 Transportation Engineering

Transportation means movement of passengers and goods by means of vehicles on land, ship on water and aircrafts in air. Transportation engineering is that branch of civil engineering which deals with planning, designing and construction of roads, bridges, railways, tunnels, harbors, ports, docks, runways, and airports. As for the development of any nation, good transportation network is of prime importance.

Transportation engineering is the application of technology and scientific principles to the planning, functional design, operation and management of facilities for any mode of transportation in order to provide for safe, efficient, rapid, comfortable, convenient, economical, and environmentally compatible movement of people and goods. It is a sub-discipline of civil engineering.

Providing good and economical road links is an important duty of civil engineers. It involves design and construction of base courses, suitable surface finishes, cross drainage works, intersections, culverts, bridges and tunnels, etc.

Railways is another important long-way transport facility. Design, construction and maintenance of railway lines are parts of transportation engineering. Globalization has resulted into requirement of airports and harbors. For proper planning of these transport facilities, traffic survey is to be carried out. Carrying out traffic survey and then planning, designing, construction and maintenance of roads, railways, bridges, tunnels, airports and harbours is known as transportation engineering.

The planning aspects of transportation engineering relate to elements of urban planning, and involve technical forecasting decisions and political factors. Technical forecasting of passenger travel usually involves an urban transportation planning model, requiring the estimation of trip generation (how many trips for what purpose), trip distribution (destination choice, where is the traveler going), mode choice (what mode is being taken), and route assignment (which streets or routes are being used). More sophisticated forecasting can include other aspects of traveler decisions, including auto ownership, trip chaining (the decision to link individual trips together in a tour) and the choice of residential or business location (known as land use forecasting). Passenger trips are the focus of transportation engineering because they often represent the peak of demand on any transportation system.

The design aspects of transportation engineering include the sizing of transportation facilities (how many lanes or how much capacity the facility has), determining the materials and thickness used in pavement, designing the geometry (vertical and horizontal alignment) of the roadway (or track).

Roads are the key to the development of an economy. A good road network constitutes the basic infrastructure that accelerates the development process through connectivity and opening up of the backward regions to trade and investment. Roads also play a key role in inter-modal transport development establishing links with airports, railway stations and ports. In addition, they have an important role in promoting national integration, which is particularly important in a large country like India. Since independence, there has been a tremendous increase in the volume of road traffic, both passenger and freight.

Of all the modes of transport, road transport is nearest and at the easiest approach of people. The goods and people have to be first moved by road before reaching other modes of transport.

### ***I. Advantages of Road Transport***

- Less capital outlay
- Door to door service
- Service in rural areas
- Flexible service
- Suitable for short distance
- Lesser risk of damage in transit
- Saving in packing cost
- Rapid speed
- Less cost

### ***II. Disadvantages of Road Transport***

- Seasonal nature
- Accidents and breakdowns
- Unsuitable for long distance and bulky traffic
- Slow speed
- Lack of organization

### ***III. Advantages of Railway Transport***

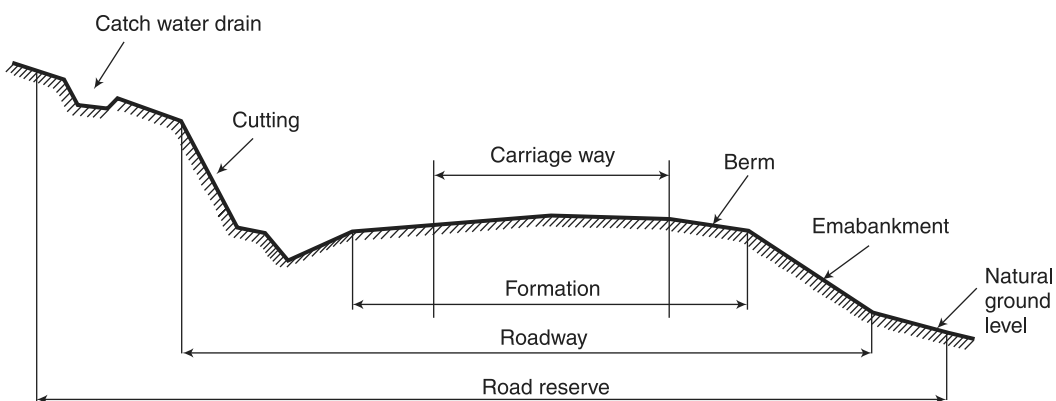
- Dependable
- Better organised
- High speed over long distances
- Suitable for bulky and heavy goods
- Cheaper transport
- Safety
- Larger capacity
- Public welfare
- Administrative facilities of government
- Employment opportunities

#### IV. Disadvantages of Railway Transport

1. Huge capital outlay
2. Lack of flexibility
3. Lack of door to door service
4. Monopoly
5. Unsuitable for short distance and small loads
6. Booking formalities
7. No rural service
8. Under-utilized capacity
9. Centralised administration

##### 1.1.10.1 Highway Engineering

Road network provides the arterial network to facilitate trade, transport, social integration and economic development. It facilitates specialization, extension of markets and exploitation of economies of scale. It is used for the smooth conveyance of both people and goods. Transportation by road has the advantage over other means of transport because of its easy accessibility, flexibility of operations, door-to-door service and reliability. Consequently, passenger and freight movement in India over the years have increasingly shifted towards roads vis-à-vis other means of transport.



**Fig 1.11** Cross section of Highway

The history of highway engineering gives us an idea about the roads of ancient times. Roads in Rome were constructed on a large scale and radiated in many directions helping them in military operations. Thus, they are considered to be pioneers in road construction.

**1. Roman Roads** The earliest large scale road construction is attributed to Romans who constructed an extensive system of roads radiating in many directions from Rome. Romans recognized that the fundamentals of good road construction were to provide

good drainage, good material and good workmanship. Their roads were very durable, and some still exist. The roads were bordered on both sides by longitudinal drains.

**2. British Road** The British government also gave importance to road construction. The British engineer John Macadam introduced what can be considered as the first scientific road construction method. Stone size was an important element of Macadam recipe. By empirical observation of many roads, he came to realize that 250 mm layers of well compacted broken angular stone would provide the same strength and a better running surface than an expensive pavement founded on large stone blocks. Thus, he introduced an economical method of road construction.

Use of bituminous concrete and cement concrete is the most important development. Development of new equipment helps in the faster construction of roads. Many easily and locally available materials are tested in the laboratories and then implemented on roads for making economical and durable pavements.

**3. Classification of Highways** The roads can be classified in many ways. The classification based on speed and accessibility is the most generic one. Note that as the accessibility of road increases, the speed reduces. Accordingly, the roads can be classified as follows in the order of increased accessibility and reduced speeds.

- **Freeways:** Freeways are access controlled divided highways. Most freeways are four lanes, two lanes each direction, but many freeways widen to incorporate more lanes as they enter urban areas. Access is controlled through the use of interchanges, and the type of interchange depends upon the kind of intersecting roadway.
- **Expressways:** They are superior type of highways and are designed for high speeds (120 km/h is common), high traffic volume and safety. They are generally provided with grade separations at intersections. Parking, loading and unloading of goods and pedestrian traffic is not allowed on expressways.
- **Highways:** They represent the superior type of roads in a country. Highways are of two types: rural highways and urban highways. Rural highways are those passing through rural areas (villages) and urban highways are those passing through large cities and towns, i.e. urban areas.

*Based on Usage* This classification is based on whether the roads can be used during different seasons of the year. All-weather roads are those roads which are negotiable during all weathers, except at major river crossings where interruption of traffic is permissible up to a certain extent. Fair-weather roads are negotiable only during fair weather.

*Based on Carriage Way* This classification is based on the type of the carriage way or the road pavement. Paved roads with hard surface are provided with a hard pavement course (for example, stones, Water bound macadam (WBM), Bituminous macadam (BM), concrete roads). Unpaved roads are not provided with a hard course of at least a WBM layer. Thus, earth and gravel roads come under this category.

*Based on Pavement Surface* Based on the type of pavement surfacing provided, roads are classified as surfaced and unsurfaced roads. Surfaced roads (BM, concrete) are provided

with a bituminous or cement concreting surface. Unsurfaced roads (soil/gravel) are not provided with a bituminous or cement concreting surface.

*Other Criteria* Roads may also be classified based on the traffic volume in that road, load transported through that road, or location and function of that road. Based on traffic volume, they are classified as heavy, medium and light traffic roads. Based on the load carried by these roads, they can be classified as class I, class II, etc. or class A, class B, etc. and the limits may be expressed as tones per day. The classification based on location and function should be a more acceptable classification since they may be defined clearly.

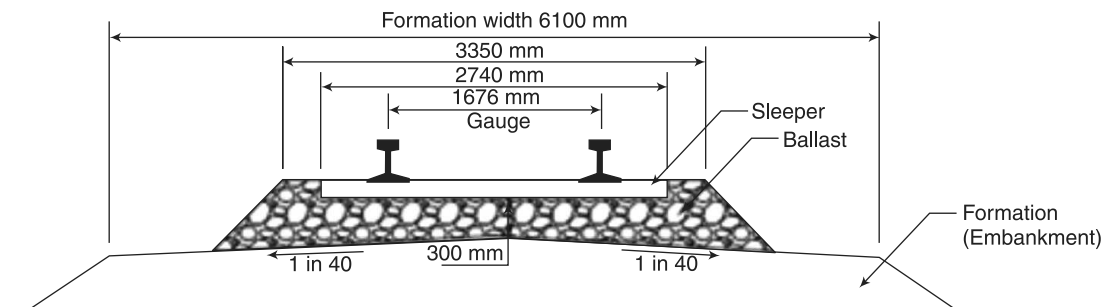
### 1.1.10.2 Railway Engineering

**1. Introduction** In 1832, the first railway running on steam engine was launched in England. Thereafter, on 1st of August 1849, the Great Indian Peninsular Railways Company was established in India.

On 17th of August 1849, a contract was signed between the Great Indian Peninsular Railways Company and East India Company. As a result of the contract, an experiment was made by laying a railway track between Bombay and Thane (56 km).

On 16th April 1853, the first train service was started from Bombay to Thane. On 15th August 1854, the second train service commenced between Howrah and Hubli. On the 1st July, 1856, the third train service in India and first in South India commenced between Vyasarpadi and Walajah Road and on the same day, the section between Vyasarpadi and Royapuram by Madras Railway Company was also opened. Subsequently, construction of this efficient transport system began simultaneously in different parts of the country.

By the end of 19th century, 24752 km of rail track was laid for traffic. At this juncture the power, capital and revenue rested with the British. Revenue started flowing through passenger as well as through goods traffic.



**Fig. 1.12** Cross section of Railway Track

**2. Gauge** The clear minimum horizontal distance between the inner (running) faces of the two rails forming a track is known as gauge. Indian railway followed this practice. In European countries, the gauge is measured between the inner faces of two rails at a point 14 mm below the top of the rail.



Different gauges in Indian Railways are as follows:

1. Broad gauge (BG) 1676 mm
2. Metre gauge (MG) 1000 mm
3. Narrow gauge (NG) 762 mm
  - Broad Gauge: When the clear horizontal distance between the inner faces of two parallel rails forming a track is 1676 mm, the gauge is called broad gauge (BG).
  - Metre Gauge: When the clear horizontal distance between the inner faces of two parallel rails forming a track is 1000 mm, the gauge is known as metre gauge (MG).
  - Narrow Gauge: When the clear horizontal distance between the inner faces of two parallel rails forming a track is either 762 mm or 610 mm, the gauge is known as narrow gauge (NG).

**3. Rails** Rails are the members of the track laid in two parallel lines to provide an unchanging, continuous, and level surface for the movement of trains. To be able to withstand stresses, they are made of high-carbon steel.

**4. Sleepers** Sleepers are the transverse ties that are laid to support the rails. They have an important role in the track as they transmit the wheel load from the rails to the ballast. Several types of sleepers are used in Indian Railways.

**5. Ballast** Ballast is a layer of broken stones, gravel, moorum, or any other granular material placed and packed below and around sleepers for distributing load from the sleepers to the formation. It provides drainage as well as longitudinal and lateral stability to the track.

#### **6. Requirement of an Ideal Permanent Railway Track**

The following are the principal requirements of an ideal permanent way or of a good railway track:

- The gauge of the permanent way should be uniform, correct and should not get altered.
- Both the rails should be at the same level on tangent (straight) portion of the track.
- Proper amount of superelevation should be provided to the outer rail above the inner rail on curved portion of the track.
- The permanent way should be sufficiently strong against lateral forces.
- The curves provided in the track should be properly designed.
- An even and uniform gradient should be provided throughout the length of the track.
- The tractive resistance of the track should be minimum.
- The design of the permanent way should be such that the load of the train is uniformly distributed on both the rails so as to prevent unequal settlement of the track.



- It should provide adequate elasticity in order to prevent the harshness of impacts between the rails and the moving wheel loads of a train.
- It should be free from excessive rail joints and all the joining should be properly designed and constructed.
- All the component parts such as rails, sleepers, ballast, fixtures and fastenings, etc. should satisfy the design requirements.
- All the fixtures and fastenings such as chairs, bearing plates, fish plates, fish bolts, spikes, etc. should be strong enough to withstand the stresses occurring in the track.
- All the points and crossings laid in the permanent way should be properly designed and carefully constructed.
- It should be provided with fence near level crossings and also in urban areas.
- It should be provided with proper drainage facilities so as to drain off the Rainwater quickly away from the track.
- It should be provided with safe and strong bridges coming in the alignment of the track.
- It should be so constructed that repairs and renewals of any of its portion can be carried out without any difficulty.

#### **1.1.11 Town Planning and Architecture**

Town planning means planned and controlled growth of town by dividing it into different land use zones and regulating building construction to provide better environment for the people of the town. In town planning, areas of town are divided into residential, commercial, recreational and industrial zones, which is called zoning.

With the growth of population and industries, new towns are coming up and existing ones are growing. Proper town planning is to be made by civil engineers. Structures should be aesthetically good also. Architecture covers this area. This field of civil engineering has grown up so much that it has become a separate branch of engineering.

#### **1.1.12 Surveying**

For planning all developmental activities, proper maps are required. The science of map making is known as surveying. Survey maps provide the relative positions of various objects of the area in the horizontal as well as vertical directions. Earlier conventional instruments like chain, tape, compasses, theodolites and levels were used for various measurements in surveying.

In this electronic era, the modern equipment like electronic distance meters and total stations are used for measurements. Modern technology like remote sensing has made surveying vast area possible in a short period. Surveying includes measurements of distances and angles in horizontal and vertical planes, while leveling is the measurement of heights in vertical plane. Surveying fixes the relative positions of different points on the basis of surface of earth.

It also includes measurements of areas and volumes. Basic aim of surveying is to prepare a map of the area to some scale. Surveying is carried out to fix the alignment of road railway canal. It is also useful in selecting the site for the construction of structures. Modern surveying instruments like Electronic total station and Geographical Positioning System (GPS) are the modern electronic digital instruments for survey works.

Remote sensing and Geographical Information system (GIS) are adopted for surveying and planning of many civil engineering projects.

### **1.1.13 Drawing**

Drawing is the language of engineers. The survey maps and plans, building description, etc. are to be provided with neat scaled drawings.

### **1.1.14 Estimation and Specification**

Civil engineers have to prepare estimation and detailed specifications for each and every work to be taken up.

### **1.1.15 Management Techniques**

Civil engineers must manage men, materials and equipment efficiently. Since huge funds are to be handled in civil engineering projects, a civil engineer must know the basics in financial management and legal obligations. Knowledge of management techniques is an asset to practicing civil engineers.

### **1.1.16 Computer Applications**

Since the magnitude of designing the structures and storing information is increasing very fast nowadays, civil engineers go for computer applications. These days, neat drawings are also produced using computers. There are a good number of civil engineering software available commercially.

## **1.2 SMART CITY DEVELOPMENT – INFRASTRUCTURE DEVELOPMENT**

Good planning of towns and extension areas in the cities involves the following activities:

- (i) Each extension area should be self sufficient in accommodating offices, educational institutions, markets, hospitals, recreational facilities and residential accommodation.
- (ii) Infrastructures constructed are of energy conserving and environmental friendly
- (iii) Assured water supply is provided.
- (iv) They have a good drainage system.
- (v) Pollution free environmental conditions are prevailing.
- (vi) A well planned and built network of roads and road crossings are developed.
- (vii) Railways connections to all important cities and towns are ensured.

- (viii) Airports and harbors of national and international standards are developed. Infrastructure also involves electricity supply, without assured electric supply no city/town can develop. Internet and telephones are also desirable features. Educational facility also forms part of infrastructure. Proximity of good primary and secondary schools to residential areas is desirable. Collegiate and professional education also form part of infrastructure of a city. Good healthcare facility is a necessity. Primary health centres, specialized hospitals and doctors add to the desirable infrastructure facility.

### 1.2.1 Effects of Infrastructure Development

The following facilities are created due to infrastructures development:

1. Connecting production centres to marketing places minimize exploitation of producers by middlemen. Imports and exports became easy as a result of which whole world becomes a village.
2. Improved irrigation facility enhances agricultural products and hence producers as well as consumers are benefitted.
3. Infrastructural facility develops scope for a number of industries and it creates job opportunities.
4. Improved education and healthcare give rise to skilled and healthy work force. Quality of life of the people is improved.
5. Utilization of manpower for the benefit of mankind brings down antisocial activities.
6. In case of natural calamities, assistance can be easily extended to the affected areas and misery of affected people can be minimised.
7. Infrastructural facility improves defence system and peace exists in the country.
8. Improved economical power of the country brings a respectable status in the world. The world has realized that a government should not involve itself in production and distribution but should develop infrastructure to create an atmosphere for economical development.

## 1.3 ROLE OF CIVIL ENGINEERS

Civil engineer is the one who designs and maintains the work of public utilities. A civil engineer has to conceive, plan, estimate, get approval, create and maintain all civil engineering activities. Civil engineer has very important role in the development of the following infrastructure:

- (i) Measure and map the earth's surface.
- (ii) Plan new townships and extension of existing towns.
- (iii) Build suitable structures for the rural and urban areas for various utilities.
- (iv) Build tanks and dams to exploit water resources.
- (v) Build river navigation and flood control projects.

- (vi) Build canals and distributaries to take water to agricultural fields.
- (vii) Purify and supply water to the needy areas like houses, schools, offices, etc.
- (viii) Provide and maintain communication systems like roads, railways, harbors and airports.
- (ix) Devise systems for control and efficient flow of traffic.
- (x) Provide and maintain solid and waste water disposal system.
- (xi) Monitor land, water and air pollution and take measures to control them. Fast growing industrialization has put heavy responsibilities on civil engineers to preserve and protect environment.
- (xii) They use scientific and engineering principles for solutions of different engineering problems.
- (xiii) Also they adopt implement management techniques for better management of man, material, machines and money.

## **1.4 CIVIL ENGINEERING CONTRIBUTION TO THE WELFARE OF SOCIETY**

### **1.4.1 Basic Perceptions**

From the dawn of human history till the present day, civil engineering has contributed to ensure human beings' safety and enriching their quality of life through constructing, maintaining, and managing social overhead capital. The current industrial civilization has especially been supported by great technological achievements, which has remarkably improved the lives of mankind. However, along with the expansion and diversification of technological advancement, the influence caused by these phenomena upon nature and societies has drastically increased in its complexity and magnitude.

### **1.4.2 Civil Engineering Contributions**

1. A civil engineer applies his/her technical skills to create, improve, and maintain beautiful national land, safe and comfortable livelihood, and prosperous society, thus contributing to society through knowledge and virtue.
2. The monuments and structures speak plenty concerning sensible development of the civil engineering technology of this world.  
Examples: The Great Wall of China, Pyramids of Egypt, Roman aqueducts, The Taj Mahal, Golden Temple, Gate Bridge. These are all civil engineering marvels.
3. High-rise building, apartment tower, office tower, apartment block, or block of flats, are tall buildings or structures used for residential and/or office use. In some areas, they may be referred to as Multi Dwelling Unit or Vertical Cities.
4. The road network of India is the third largest road network in the world, consists of Expressways, National Highways and Cloverleaf interchange. All the major Indian cities are developing very fast in terms of skyscrapers, flyovers and partial cloverleaf interchange, to handle traffic.

Example: Badarpur Cloverleaf, Delhi; Yamuna Cloverleaf–Noida Mukarba Chowk Cloverleaf, Wazirabad, BMIC Cloverleaf – Bangalore – Mysore Infrastructure Corridor, Kathipara Cloverleaf, Maduravoyal Cloverleaf, Koyambedu Cloverleaf – Chennai.

5. Flyovers are constructed with the aim of saving time and reducing congestion in city roads. They are planned above the roads which have dense markets/shopping areas running along them, thus properly dividing traffic on the pathway.
6. Over bridges are constructed to continue the road in the presence of obstacles like rail tracks, rivers, valleys, lowlands, etc. They are preferred when there is no other option of a vehicular pathway over the obstacle than an over bridge itself.

Examples are: Brahmaputra Bridge, Assam; Mahatma Gandhi Setu, Bihar; Indira Gandhi Setu Tamil Nadu; Rajiv Gandhi Setu, Maharashtra; Rabindra Setu, West Bengal; Narmada Bridge, Gujarat; Naini Bridge, Uttar Pradesh; Jadukata Bridge, Meghalaya.

7. Construction of a dam across river results in the ponding of water on its upstream side conveniently used for irrigation purposes. India has 5,202 large dams. These dams are specially designed for flood control and generates high electric power.

Examples: Cheruthoni Dam, Kerala; Indira Sagar Dam, Madhya Pradesh; Krishnarajasagar Dam, Karnataka; Mettur Dam, Tamil Nadu; Bisalpur Dam, Rajasthan; Koyna Dam, Maharashtra; Maithon Dam, Jharkhand; Rihand Dam, Uttar Pradesh; Bhavanisagar Dam, Tamil Nadu.

8. Civil engineering contributions in information technology has brought about a sarcastic changes in India. Amazing spectacular office buildings are constructed in the last two decades.

Examples: I-Flex Solutions, Bangalore; Signature Towers, Gurgaon; EDRC, Chennai; Patni Knowledge Park, Mumbai; Oracle, Bangalore; Microsoft Building, Hyderabad; Adobe Headquarters, Noida; TCS, Hyderabad; LandT Infotech, Chennai; Infosys, Pune; Bharti Airtel, Delhi; Wipro, Noida; DLF Gateway, Gurgaon; ICICI Bank Headquarters, Mumbai; Syntel, Chennai; Cyber Towers, Hyderabad; Air India Building, Mumbai; UB City, Bangalore; Mahindra Satyam, Hyderabad; IT Park, Chandigarh; EON IT Park, Pune; TCS Office, Chennai.

9. Modern Health care centres and hospitals and pharmaceutical Industries are contributions in the Health Care sector.

Example: AIIMS, Delhi; Apollo, Chennai; Jipmer, Pondicherry; Christian Mission Hospital, Vellore.

10. Large Scale steel industry, cement plants, automobile industry, thermal power plants, atomic centres, rocket launch pads, etc. are the developments carried out by civil Engineers.

## **1.5 ETHICAL PRINCIPLE**

Ever cognizant of the profound interrelationship of their profession with both human society and nature, civil engineers shall work for the development of technology, deepen and consolidate their knowledge, contribute by means of their wisdom, skills, and virtues to both the peace and prosperity of the people and the nation, and to the welfare and sustainable development of humanity.

### **1.5.1 The Code of Professional Conduct**

Civil engineers shall:

1. Contribute to society and utilize their expertise and experience to develop and implement.
2. Give comprehensive solutions to issues of public interest, keeping in mind the peace and prosperity of the people and the development of society as their constant concern.
3. Respect both nature and the fabric of civilization and culture; Respect nature indispensable to the survival and development of humanity while holding in esteem diverse civilizations and cultures.
4. Ensure the security of society and mitigate disasters. Be committed to aiding in protecting the life and property of the people, working with colleagues across a broad range of disciplines, while looking beyond their professional expertise to the concerns of the people, realizing both the capabilities and the limitations of technology with the people.
5. Fulfill their professional responsibilities; recognize the essentially social significance of their work and thus endeavor to fulfill their duty to society.
6. Guard their integrity and avoid any conflicts of interest; be fair and unbiased in all their interactions with the people, their clients, the organizations for which they work, as well as themselves, faithfully and honestly discharging their duties and avoiding any conflicts of interest.
7. Openly provide information and engage in public dialog. For the sake of the general welfare, be pro-active in sharing their expertise and knowledge in their endeavors and communicate in an open exchange of views with the people.
8. Make known the results of their research endeavors. Publish their findings and policy recommendations with research papers and reports in conformity with both their scientific convictions and their own consciences, sharing these with both their professional colleagues and the people, always mindful of objective facts and the intellectual achievements of others.
9. Strive for self-improvement and human-resource development. Cultivate and nurture their virtues, general knowledge and professional competence, pursue scientific endeavors in the realms of both scientific and practical theories for the

sake of technological advances, and put to use their individual abilities, experience, and merits for the education and training of engineers.

10. Comply with established norms. Carry out their work in full understanding of all laws, rules, and regulations as well as of well-founded principles, actively and willingly taking the lead in the observance of societal standards and seeking to improve them in response to both social and technological change.

## **1.6 CONTRIBUTION OF MECHANICAL ENGINEERING TO THE SOCIETY**

1. Mechanical engineering provides better transport facilities to the society, as it includes the study of internal combustion engineering.
2. Large number of benefits to the society, due to the economical improvement of the country, become of industrial development, chance for export of articles was also be increases.
3. Due to large industrial development, new power stations have to be started.
4. Increased employment opportunities will be created in the field of industries and power stations.
5. Also, the chance for employment opportunities allowed becomes high for mechanical engineering industries. The saving allowed is quite high.

## **1.7 INTRODUCTION TO METAL CASTING PROCESS**

Metal casting is one of the most versatile forms of production processes. There is no limit to the size and shape of the articles that can be produced by casting. The production cost is considerably low. Although all metals can be cast, iron is mostly used because of its fluidity, small shrinkage and ease with which its properties are controlled.

Casting process involves the pouring of molten metal into a cavity or mould of the desired shape and size, and allowing it to solidify. When it is removed from the mould, the casting is of the same shape but slightly smaller due to the contraction of metals. The process requires moulding sand which can withstand high temperatures. By using a replica of the required cast which is called a pattern, a cavity of the desired shape and size is made in the moulding sand. The metal is melted in a furnace and poured in the cavity. After the solidification is completed, the casting is removed and cleaned.

## **1.8 ADVANTAGES OF THE CASTING PROCESS**

1. The cost involved in the casting process is very low compared to the other manufacturing processes.
2. Very heavy and bulky parts which are difficult to fabricate can be manufactured by the casting process.
3. Casting can be employed for the mass production as well as for batch production.
4. A product can be cast as a single piece and hence the metal joining process is eliminated.



## 1.9 PATTERNS

A pattern is a model or a replica of the object to be manufactured around which moulding sand is packed to get a mould of desired shape and size.

The quality of casting in terms of dimensional accuracy, surface finish, and mechanical properties depends largely on the material used for the patterns, type of pattern, design and construction of patterns. Hence, a lot of preparation is necessary before starting the production of patterns. The preparation includes making decision about,

1. The type of materials to be used;
2. The type of pattern to be adopted;
3. The tolerance and allowances to be provided;
4. The constructional details, including the provision of loose pieces, core boxes and
5. The method of gating and feeding to be adopted.

### 1.9.1 Pattern Materials

In a metal casting process, the quality of castings is also influenced by the pattern materials. It is necessary to select the right material that can give the desired quality at the minimum cost. The selection of pattern materials depends on the following:

1. The number of casting to be manufactured.
2. The desired level of dimensional accuracy and surface finish required.
3. The shape and size of the casting.
4. The design and fine details of the casting.
5. The type of moulding processes.
6. The method of moulding, i.e., sand moulding or machine moulding. Patterns may be made by using materials such as wood, metals, plastics, plaster and wax.

**1. Wood** Wood is the material most commonly used for making patterns for sand moulding, Wood can be easily shaped or worked with to get patterns of desired shape and size. It is light in weight, abundantly available, cheap and can be handled easily.

However, wood is easily affected by moisture, and it possesses less strength. Hence, it is not suitable for mass production. The most common types of wood used are mahogany, teak and pine.

**2. Metals and Alloys** Metal patterns are mostly cast from wooden patterns or machined to desired shape. Metal patterns are stronger, accurate and durable. The other advantages are its ability to withstand rough handling, high resistance to warp, wear and abrasion.

However, metal patterns are expensive and not easily repaired. Ferrous metals get rusted. Metals are heavier and difficult to handle. Metals cannot be machined easily. Metal patterns are used when the number of castings to be manufactured is large. Aluminium and its alloys, steel, cast iron, brass and white metal are the different metals used for making patterns.



**3. Plastics** Plastic patterns are prepared with the help of wooden patterns. Plastics are light. These are moisture resistant and provide a smooth surface. These are also wear and corrosion resistant. Plastic patterns are durable and do not involve any appreciable change in size or shape.

However, plastic patterns are weak and need metal reinforcement for light sections. Plastic patterns are also not suited for machine moulding.

Both the thermosetting and the thermoplastic materials are used for making patterns. Common plastic materials used for making patterns are epoxy resin, polyester resins and polystyrene.

**4. Plaster** Plaster pattern is also made with the help of wooden patterns. Plaster pattern can be easily worked by using wood working tools. Intricate shapes can be made easily. Plaster has a high compressive strength. Hence, the plaster pattern is used for making small and intricate castings and core boxes. Materials such as plaster of Paris or gypsum cement are commonly used for plaster patterns.

**5. Wax** The wax pattern is made in a water cooled metal mould or a die. The wax pattern provides a very good surface finish and high accuracy. For removing the wax pattern, the mould with the pattern is inverted and heated to make the wax melt away. The wax pattern is used in investment casting or lost wax process.

### 1.9.2 Pattern Allowances

In the metal casting process, the pattern is used to manufacture a casting of the desired dimensions, but the pattern is not made dimensionally identical with the casting. The various reasons are the following:

1. All metals shrink in size when there is a change from the liquid to the solid state.
2. Castings require surface finishings.
3. The pattern should be removed from the mould cavity without tearing the mould cavity surface.
4. Casting tends to warp or distort during the cooling stage.

Therefore, the patterns are made with certain allowances on size. The various patterns allowances include the following:

1. Shrinkage allowance.
2. Finishing allowance or machining allowance.
3. Draft allowance or taper allowance.
4. Distortion allowance or camber allowance.
5. Shaking allowance or rapping allowance.

For quality castings, there should be a balance between all these allowances.

**1. Shrinkage Allowance** Shrinkage allowance is the allowance given on the pattern size for avoiding any change in the dimensions of the casting because of the shrinkage of the metal during solidification.

Different metals shrink differently and have different shrinkage allowances. Shrinkage allowances for important casting metals are given below:

Grey cast iron	7-10.5 mm/m
Steel	20 mm/m
Aluminium	18 mm/m

Shrinkage allowances are given by using a shrink rule which includes the proportionate allowances on every measurement. Shrink rules are available for every casting metal. The shrinkage allowance to be given depends on the following major factors:

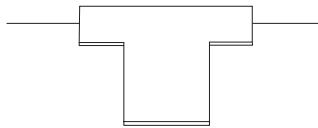
1. The type of metal being used
2. The size and shape of the casting and
3. The moulding medium.

**2. Finishing Allowance or Machining Allowance** The finishing or machining allowance is the allowance given on size of the pattern for finishing or machining the rough surface of the casting. The standard finishing allowance for ferrous metal is 3 mm and that for nonferrous metals is 1.5 mm. The finishing or machining allowance to be given depends on the following major factors:

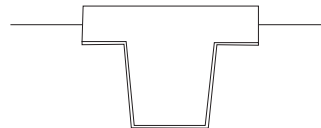
1. The type of metal being used.
2. The casting design.
3. The method of casting.
4. The method of cleaning and
5. The degree of finish required for the casting.

**3. Draft Allowance or Taper Allowance** Draft allowance is the taper allowed on vertical faces of a pattern for easy removal of the pattern without damaging the mould cavity surface as given in Figs. 1.13(a) and 1.13(b). A draft of 3-6 mm per metre is generally adopted. For patterns used in machine moulding, normally one degree taper is given. This allowance depends on the following factors:

- (1) The size and shape of the casting.
- (2) The length of the vertical face of the casting.
- (3) The method of moulding and
- (4) The intricacy or fine details of the casting.



**Fig. 1.13(a)** Pattern having no Draft Allowance

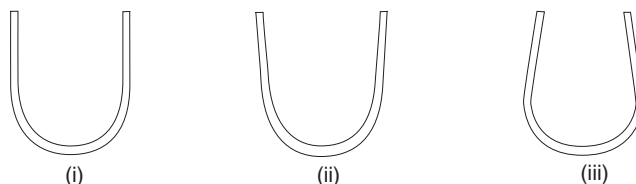


**Fig. 1.13(b)** Pattern having Draft Allowance

**4. Distortion or Camber Allowance** Due to the internal stresses developed during cooling, the casting may be distorted. For example, if the casting has a U-shape, it will tend to cool faster at the ends, giving rise to internal stresses in the bent portion. As a result, on cooling, the legs of the casting would deflect outwards as shown below in Figs. 1.14(a) and 1.14(b).

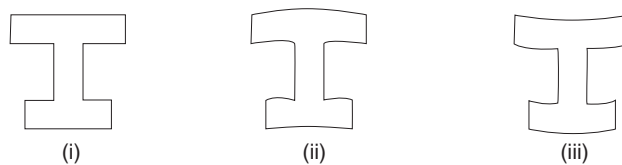
Distortion allowance is given to avoid this by intentionally deflecting the leg inwards. This allowance depends on the following factors:

1. The type of metal being used;
2. The design of the casting; and
3. The length of thin section in casting.



(a) U-shaped Casting

- (i) Required shape of casting  
(ii) Casting produced with distortion  
(iii) Pattern provided with Camber allowance



(b) I-section Casting

- (i) Required shape of casting  
(ii) Casting casting  
(iii) Cambered pattern

**Fig. 1.14** *Distortion or Camber Allowance*

Distortion allowance is given based on previous experience or the distortion produced in a casting made with a pattern without any distortion allowance is measured and then the allowance is provided on the pattern.

**5. Shake Allowance or Rapping Allowance** For the easy withdrawal of the pattern from the moulding sand, the pattern is slightly rapped or shaken around the vertical faces which leads to a slight enlargement in the mould cavity. So, the final casting will be slightly over sized. The shake allowance is given to overcome this problem, by making the pattern slightly smaller in size.

### 1.9.3 Types of Patterns

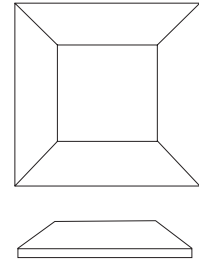
In the metal casting process, various types of patterns can be used; but it is necessary to select a particular type of pattern for our application. The various factors to be considered to the selection of a pattern type are the following:

1. Shape and size of the casting
2. Number of casting

3. Method of moulding adopted
4. Complexity and intricacy of the casting
5. Accuracy required; and
6. Problems associated with the moulding operation such as the removal of patterns from the mould.

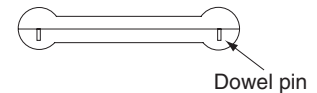
The various types of patterns commonly used are explained in the following sections;

**1. Solid Pattern or Single Piece Pattern** The simplest form of pattern made without any joints, partings or loose pieces in its construction is called a solid or single piece pattern as shown in Fig. 1.15(a). It is inexpensive and generally used for large castings of simple shape.



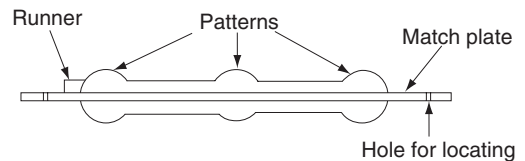
**Fig. 1.15(a)** *Single Piece Pattern*

**2. Split Pattern** All patterns cannot be made in a single piece because of the difficulties faced in removing them from the mould. To overcome this problem, some patterns are made in two parts so that half of the pattern will rest in the lower part of the mould and the other half in the upper part. The two parts are aligned by means of dowel pins as shown in Fig. 1.15(b). Some complicated casting requires three or more parts to be constructed and such a pattern is called a multi-piece pattern.



**Fig. 1.15(b)** *Split Pattern*

**3. Match Plate Pattern** In match plate patterns, each half of the patterns are mounted on opposite sides of a plate called a match plate. This is widely used in machine moulding. The gates and runners are also attached to the plate. The match plate pattern is aligned by means of locator holes in the match plate and locating pins on the moulding box as shown in Fig. 1.15(c).



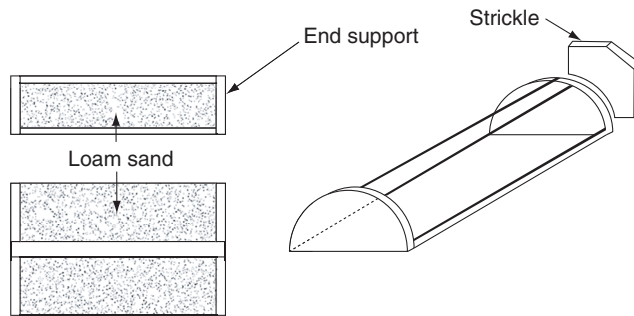
**Fig. 1.15(c)** *Match plate pattern*

**4. Loose Piece Pattern** It is a pattern with loose pieces which are necessary to facilitate the withdrawal of the pattern from the mould as in Fig. 1.15(d). Loose pieces are removed separately by turning or moving through the cavity formed after the main pattern has been removed. These loose pieces are fastened loosely to the main part by means of wooden dowel pins.



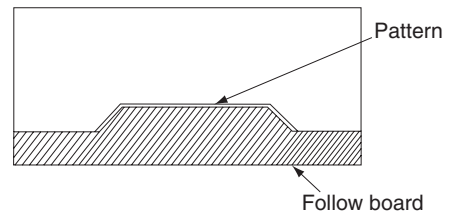
**Fig. 1.15(d)** *Loose Piece pattern*

**5. Skeleton Pattern** Skeleton pattern is used for making a few large castings. The skeleton pattern has a wooden framework filled with loam sand. This is to save the amount of pattern materials used. The final shape is given with a strickle. It is shown schematically Fig. 1.15(e).



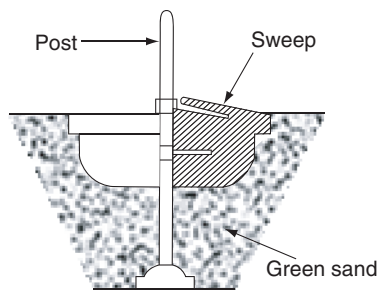
**Fig. 1.15(e)** *Skeleton Pattern*

**6. Follow Board Pattern** Follow board pattern is used for casting which has some structurally weak portions which need some support for avoiding breakage during the moulding process. Hence, these weak portions are supported by means of a board that will closely fit the contour of the weak pattern. This arrangement is shown in Fig. 1.15(f).



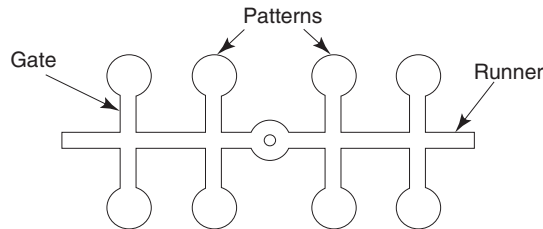
**Fig. 1.15(f)** *Follow board pattern*

**7. Sweep Pattern** Sweep patterns are used to manufacture large casting of symmetrical shape and with a circular cross-section. A sweep pattern consists of a wooden board with outer contour similar to the casting's form. This board is fixed to a metal rod and rotated about the metal rod as the axis of rotation, for getting a complete mould cavity. This arrangement is shown in Fig. 1.15(g). This pattern is economical, since only a wooden board is used instead of large-size expensive solid pattern.



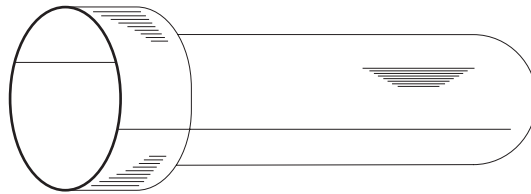
**Fig. 1.15(g)** *Sweep pattern*

**8. Gated Pattern** When large number of small castings are required, gated patterns are used. Such patterns are usually made of metal to give them strength. The gates and runners for the molten metal are formed by the connecting parts between individual patterns as shown in Fig. 1.15(h).



**Fig. 1.15(h)** Gated pattern

**9. Shell Pattern** Shell patterns are widely used for large symmetrical casting such as drainage fittings and pipes. The shell pattern consists of a hollow construction. The outside contour is used as a pattern to form the mould. The shell pattern is made of two halves, which are correctly aligned together by means of dowel pins. The shell pattern is usually made of metals and shown in Fig. 1.15(i).



**Fig. 1.15(i)** Shell pattern

**10. Cope and Drag Pattern** The cope and drag pattern is used for very large castings, in case the complete mould is too heavy and difficult to handle by a single operator. The cope and drag pattern is made in two halves. Both are moulded separately and are then assembled to make the complete mould.

#### 1.9.4 Pattern Making

Considering the importance of the pattern in the metal casting process, it is necessary to select proper equipment, machines, tools and instruments for pattern making. These requirements depend on the pattern materials used and the method of making.

Wooden pattern may be hand worked or machine worked. For making wooden patterns, utensils such as work benches, carpenter's vice, circular saw, band saw, wood planer, disc sander, pattern maker's lathe, pattern milling machine, and wood boring machine are required. For machining a metal pattern, traditional machines such as the lathe, milling machine, drilling machine, shaper, planner, and grinding machine are used.

## 1.10 MOULDING

Once the pattern of correct shape and size of the casting is prepared, it is necessary to make a cavity with the help of a medium. The process of making this cavity of the desired shape and size on a medium is called moulding. The medium may be ordinary moulding sand or resin-bonded sand. In case of diecasting, metal moulds are used.

### 1.10.1 Moulding Sand

Moulding sand is the medium in which the cavity is made for the casting. It consists of a mixture of basic ingredients such as the refractory sand, grains, binders, water and some additives details of which are dealt in Section 1.10.3.

### 1.10.2 Properties of Moulding Sand

The principal properties of the moulding sand are the following:

**Refractoriness** It is the ability of the moulding sand to withstand the high temperature of the molten metal so that it does not cause fusion.

**Strength** The moulding sand should have sufficient strength (green strength, dry strength and hot strength) to retain the mould shape under green (5 to 8% water content), dry and hot conditions respectively.

**Flowability** Flowability is the ability of the moulding sand to get compacted to take up the required shape. Flowability increases as clay and water contents increase.

**Porosity or Permeability** The moulding sand should be porous enough to allow the gases picked up by the molten metal while transferring or gases generated in the mould to escape from the mould. This capability of the moulding sand is known as permeability.

**Strength or Cohesiveness** It is the ability of the moulding sand grains to adhere to each other. It is necessary for a uniform packing of the moulding sand while preparing a mould.

**Adhesiveness** Adhesiveness is the property of moulding sand to adhere to the walls of moulding boxes. It is necessary to enable the safe handling of the mould from one place to another.

**Collapsibility** Collapsibility is the readiness of the moulding sand to get collapsed, after the solidification of the casting.

**Durability** It is the ability of the moulding sand to withstand the heating and cooling during repeated usage.

**Chemical Resistivity** It is the ability of the moulding sand to resist any chemical reaction with the molten metal.

### 1.10.3 Ingredients of Moulding Sand

The principal ingredients of moulding sand are the following:

**Refractory Sand Grains** This is a mixture of silica sand  $\text{SiO}_2$  (80-90%), alumina and magnesium oxide. Refractory sand grains give the refractoriness, chemical resistivity and permeability of the moulding sand.

**Binders** Binder provides the necessary bonding strength to the moulding sand and it holds the sand together. Clay is most commonly used binder along with the moulding sand. Kaolinite or fire clay and bentonite are the most commonly used binders.

**Water** Water is added to activate the clay in the moulding sand. The addition of water develops the necessary plasticity. The amount of water should be kept within certain range as excess water decreases the strength and the formability of the moulding sand. Normally, the water content is in the range of 2-8 per cent.

**Additives** In addition to these basic ingredients, any other materials added to get some specific properties in the moulding sand are called additives. These are mixed with the moulding sand during sand preparation. Some common additives and their purposes are given below:

Coal dust—for protecting the mould surface against the action of molten metal and to get a good surface finish.

Dextrin—for increasing the toughness and collapsibility.

Iron oxide powder—for getting high temperature plasticity, hot strength and anti-metal penetration properties for the moulding sand.

Molasses—for higher dry strength and collapsibility.

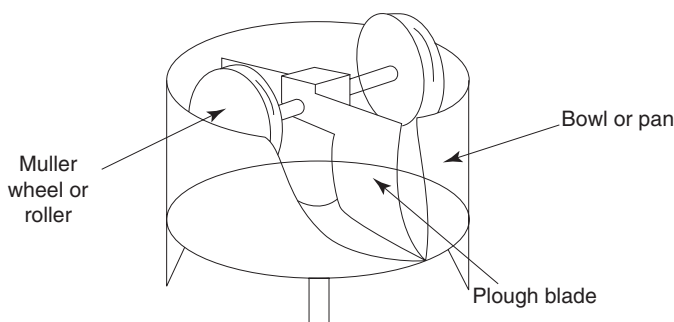
### 1.10.4 Preparation of Moulding Sand

Sand preparation means mixing the moulding sand ingredients such as sand, binder, water and other additives. Mixing may be carried out manually or by mechanical means. For the mechanical mixing, the sand muller is used.

A moulding sand muller basically consists of a cylindrical bowl or a pan. Inside the bowl, there are two heavy rollers which roll in a circular path about a vertical rotating shaft. In addition to this, there are two plough blades which force the moulding sand towards the rollers for homogeneous mixing. The schematic diagram is shown in Fig. 1.16.

For mechanised casting, high speed sand muller with two or more high speed wheels rotating in a horizontal plane are used.





**Fig. 1.16** Sand Muller

### 1.10.5 Types of Sand Moulding

Sand moulding is classified according to the type of moulding sand used as given below:

**1. Green Sand Moulding** In green sand moulding, the molten metal is poured when the mould is in moist condition. Green sand moulding is the most widely used type of sand moulding. The permeability of the green sand mould should be properly controlled for avoiding casting defects such as blow holes and air inclusions.

**2. Dry Sand Moulding** In dry sand moulding, the mould is prepared with the moulding sand having high dry strength and is then dried in an oven. Dry sand moulding is used for large castings and for the mould requiring greater strength.

**3. Skin Dried Moulding** In skin dried moulding, the moisture from the surface layer of the mould side only is dried to a depth of 25 mm or more by using gas torches or heaters.

**4. Loam Sand Moulding** In loam sand moulding, loam sand mortar which is a mixture of equal amount of sand grains and clay wetted to the consistency of mud is used. The loam is constructed of porous bricks joined with loam sand mortar. Skeleton patterns are used with loam moulding.

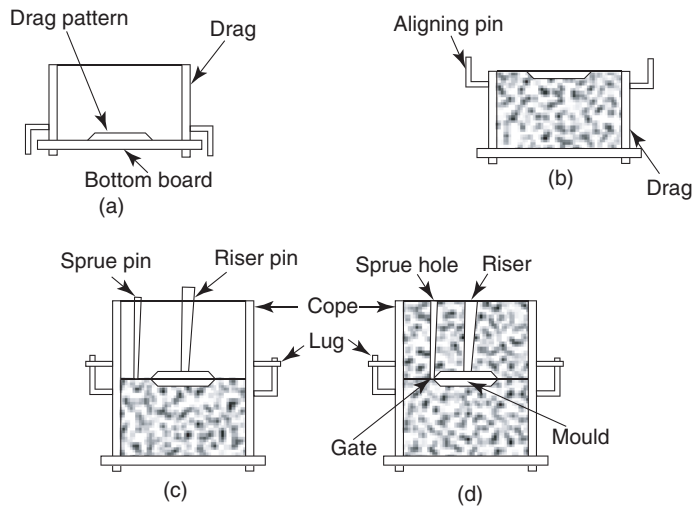
**5. Oil Sand Moulding** In oil sand moulding, moulding sand with an organic binder (linseed oil, vegetable oils, mineral oils, animal oils or natural resins) along with dextrin and bentonite are used. This is commonly used for core making.

### 1.10.6 Preparation of Green Sand Moulding

The procedure for preparing a green sand mould is as follows:

A bottom board or moulding board is placed on the moulding platform or on the floor. The drag portion of the moulding box is kept upside down on the bottom board. The drag portion of the pattern is placed at the centre of the moulding box on the moulding board with sufficient clearance between the pattern and the moulding box walls as shown in Fig. 1.17(a). Dry facing sand is sprinkled all around the patterns to avoid the sticking of pattern with the moulding sand. Then, sufficient amount of moulding sand is put into the

moulding box and on the drag pattern so as to fill the box completely. The moulding sand is added if necessary. The excess sand is subsequently removed by striking off with a bar and the moulding sand in the box is levelled. Parting sand is then sprinkled over the top of the moulding box. Vent holes are made in the drag portion for the removal of gases during solidification of the casting. This is done by using a vent wire. Now the moulding box is turned over and is kept in an upright position. This is explained in Fig. 1.17(b).



**Fig. 1.17** Green sand moulding stages and tools

The edges of sand around the drag pattern is improved. Cope portion of the pattern is placed over the drag portion and properly aligned with the help of dowel pins. The cope box is then placed over the drag box and properly aligned. A sprue pin is placed at some distance from the pattern for making the sprue hole. The sprue hole is the passage through which the molten metal from the funnel shaped cavity at the top of the mould reaches the mould cavity. Then a riser pin is kept at an appropriate place for making the riser. The riser is a reservoir of molten metal provided in the mould and it is also used as a vent. These arrangements are shown in Fig. 1.17(c). Then a sufficient amount of moulding sand is added and the entire procedure adopted for preparing the drag half of the mould is repeated. Then the sprue pin and the riser pin are carefully withdrawn. A funnel-shaped cavity is formed near the top of the sprue hole. This is called the pouring basin.

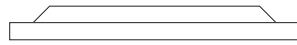
The cope is separated from the drag and the loose sands on cope and drag interface are removed. Then, the pattern halves are withdrawn carefully by using drawspikes and by rapping the pattern. The runners and the gates are cut in the mould cavity carefully without spoiling the mould cavity using the gate cutters. The loose sands are removed by blowing away with bellows. Now, the facing sand in the form of a paste is applied all over the mould cavity which is called the mould wash.

The cope is placed over the drag again after properly aligning by means of pins. The mould is now ready for pouring which can be seen in Fig. 1.17(d).

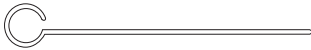
Various hand tools used for moulding are shown in Figs. 1.17(e)-(j).



**Fig. 1.17(e)** *Rammer*



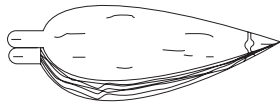
**Fig. 1.17(f)** *Strike off bar*



**Fig. 1.17(g)** *Vent wire*



**Fig. 1.17(h)** *Draw spike*



**Fig. 1.17(i)** *Bellows*



**Fig. 1.17(j)** *Gate cutter*

### 1.10.7 Cores

Cores may be defined as any projections into the mould for making cavities and hollow shapes which cannot be produced by the pattern alone. In general, cores are surrounded on all sides by the molten metal. Cores are made separately, baked and suitably placed or positioned in the mould cavity.

### 1.10.8 Moulding Machines

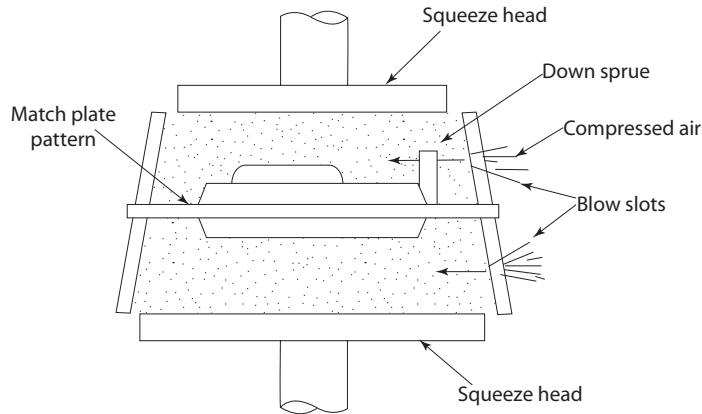
The green sand moulding done by compacting the moulding sand around the pattern by ramming the sand using the hand tools as explained in the previous section is limited to the production of very few moulds. The huge or mass production of castings is done by using machine moulding which uses techniques like squeezing, jolting, vibrating, slinging, blowing or any combined methods for compacting the moulding sand around the pattern. Various machines used to prepare the moulds are namely.

1. Squeezers
2. Jolt Machines
3. Jolt and Squeeze Machines

#### 4. Slingers

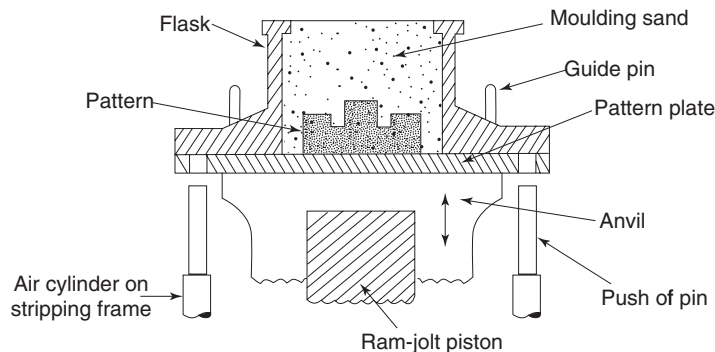
The principles of operation of each moulding machine are explained below:

**1. Squeezers** Squeeze moulding machines utilize pressure for compacting the moulding sand. The pressure may be applied through a squeezer head. This type of moulding machine is available with tight moulding chambers. These machines normally utilize gravity to fill the moulding chamber. Then the squeeze pressure is applied by air cylinders as shown in Fig. 1.18.



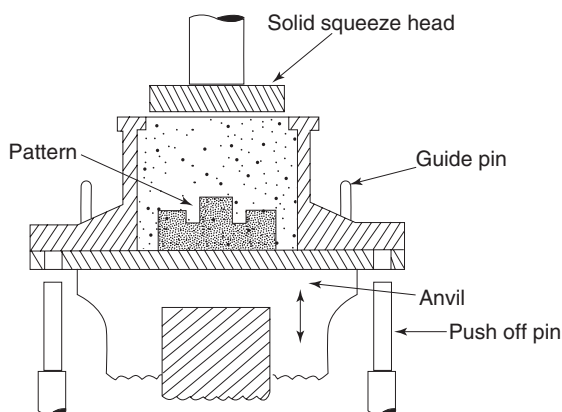
**Fig. 1.18** Squeeze moulding machine

**2. Jolt Machines** The jolt type machines operate with the pattern mounted on a pattern plate, which in turn is fastened to the machine table. A flask is placed on the pattern and positively located by pins relative to the pattern. The flask is filled with sand and the machine starts the jolt operation. This is accomplished by alternately applying and releasing air pressure to the jolt piston which causes the flask, sand and pattern to lift for few centimeters and then fall to a stop, producing a sharp jolt. This process is repeated for a predetermined number of times and due to the kinetic energy of the sand, the moulding sand will be compacted. When the process is completed, the push off pins at the bottom edge of the flask lift the flask. The operation of the jolt machine is shown in Fig. 1.19.



**Fig. 1.19** Jolt type moulding machine

**3. Jolt and Squeeze Machines** The jolt and squeeze machines operate in the same manner as jolt machines. In the mould prepared by the jolt machines, the top portion is having less density compared with the bottom portion. So, a supplemental compaction is done by a squeeze head which compacts the loose sand at the top. The required pressure for squeeze operation can be supplied by pneumatic cylinders. The operation of the jolt and squeeze machine is shown in Fig. 1.20 which can use either a solid squeeze head or a compensating squeeze head for the required squeezing action.



**Fig. 1.20** Jolt and Squeeze Type Machine

**4. Sand Slings** Sand slinging machines deliver the sand into the mould at high velocity from a rotating impeller. Moulds made by this method will have very high strength because a very dense mould can be made. Density is a function of sand velocity and the thickness through which the high velocity sand must compact the previously placed sand. Sand slingers are used to produce larger moulds.

### 1.11 MELTING OF CAST IRON

In metal casting, melting is considered to be important; because it controls the quality of the casting. A wide range of furnaces such as the pit furnace, open hearth furnace, rotary furnace, cupola furnace, and electric arc furnace are available for melting. The choice of the furnace is made based upon the amount and type of metals or alloys to be melted. A cupola furnace is most commonly used for melting cast iron.

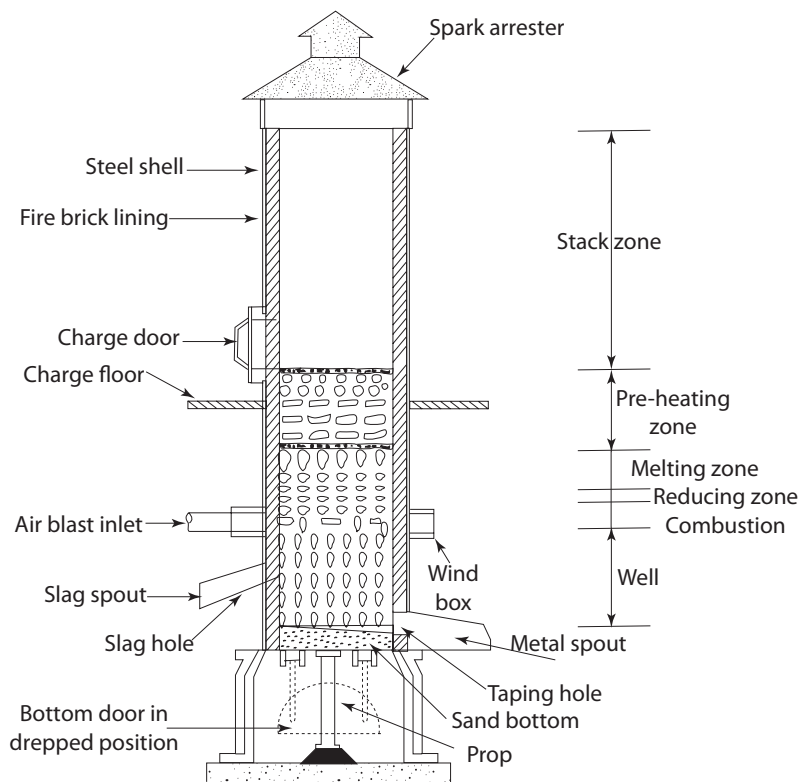
### 1.12 CUPOLA FURNACE

A cupola furnace basically consists of a cylindrical steel shell with both its top and bottom open. The inner walls of the shell are lined with heat resisting materials such as the fire brick. The bottom opening is closed by a cast iron drop bottom door supported by a metal prop. This door swings out after the melting when the metal prop support is removed. This arrangement is shown in Fig. 1.21. After closing the bottom door, a sloping sand bed is prepared for giving the necessary heat resistant bottom for the molten metal and

the fuel. Just above the sand bed is the metal tapping hole through which the molten metal is taken out to pour into the mould or the ladle. A spout called the tapping spout is provided for guiding the molten metal out. Above the tapping hole and opposite to it is a hole with a spout for removing the slag generated during the melting. It is called the slag hole.

Above the slag hole is the wind box which surrounds the cupola shell and supplies air at a given pressure and quantity. Air comes to the wind box through an air blast pipe from an air blower (not shown in the figure). Air enters into the cupola furnace through tuyers which extend through the steel shell and the refractory lining. The number of tuyers and their spacing along circumference of the shell varies with the size of the cupola furnace.

A cupola furnace is also provided with a charging platform or floor and a charging door for feeding the charges. The charge consists of pig iron, scrap iron, coke and fluxes. At its top, the cupola furnace has a metal shield or a spark arrester. It arrests the spark or burning particles from going outside while allowing the hot gases to escape out. The schematic diagram is shown in Fig. 1.21.



**Fig. 1.21** Cupola furnace

### 1.12.1 Operation of Cupola Furnace

The various steps in the operation of a cupola furnace are the following:

**1. Preparation of Cupola** The preparation of a cupola furnace begins after dropping the bottom at the completion of the previous melting. In this step, the remaining materials (coke, slag, and metal) in the cupola in the previous melting are removed. Slag, coke and the metal pieces adhering to the side linings are chipped off. Heat resistant linings are repaired with new fire bricks and clay. Then the bottom door is closed and duly supported with the metal prop. A sloping sand bed is prepared with tempered sand over the bottom door. The slope gives a better metal flow. The sand bed is prepared by uniform ramming to avoid any leakage of molten metal.

**2. Starting of Ignition** For starting the cupola, soft and dry pieces of woods are spread over the sand bed. A coke bed is prepared over the wooden pieces. The wooden pieces are ignited either through the tap hole or through some other opening. The height of coke bed is maintained in the order of about 75 cm above the tuyers by adding an additional amount of coke as the initial coke bed burns well. The ignition is started about three hours before the molten metal is needed for pouring into the moulds.

**3. Charging** After the coke bed is properly ignited, the charging is done. The charging of cupola is adding alternate layers of lime stone (flux), iron and coke upto the level of the charging floor. The flux is a substance added for slag formation and for easy removal of impurities. It also reduces the oxidation of iron and lowers the melting point of slag. It increases the fluidity of slag. lime stone ( $\text{CaCO}_3$ ) is mostly used as flux. Coke is the fuel commonly used in cupola. The metal charge consists of pig iron (30%), new scrap iron (30%) and returns (sprue, gates, risers, and defective castings).

**4. Melting** After the cupola furnace has been fully charged, the charge is allowed to get heated slowly for about 45 minutes without allowing the air blast. This is called the soaking of iron.

At the end of soaking period, the air blast is opened. The tapping hole is closed by means of a bolt or a plug till sufficient amount of molten metal gets accumulated inside the furnace. As the melting continues, additional charges are added and the charge level is kept upto the charging door during the entire operation of the cupola.

**5. Slagging and Tapping** After sufficient amount of molten metal gets accumulated inside the cupola, the slag hole is opened and the slag is removed through the spout. This process is called slagging.

The plug closing the tap hole is then removed and the molten metal is taken out through tapping spout for pouring into the mould. This process is called tapping.

**6. Dropping Down the Bottom** Once sufficient amount of molten metal is taken out from the cupola, the charging is stopped. Then all the contents of the cupola are allowed to melt by keeping the air blast closed. The metal prop is knocked down making the drop

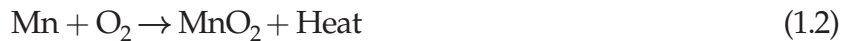
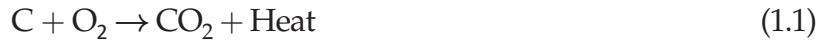
bottom door to swing out. Hence the remaining material in the cupola drops down on to the floor or into some vessels.

### 1.12.2 Zones of a Cupola Furnace

The various zones of cupola furnace (refer to Fig. 1.21) are the following:

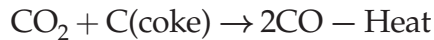
**1. Well** This extends up to the bottom of tuyers from the sand bed. It is a sort of a well of molten iron. Molten iron collects in this zone before tapping.

**2. Superheating Zone, Combustion Zone or Oxidizing Zone** The zone starts from the tuyers and extends upto 15-30 cm above the top of tuyers. Combustion takes place in this zone with the aid of oxygen from the air blast. Some exothermic reactions which occur in this zone are: (1.1)



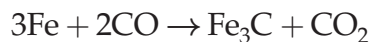
The temperature of this zone varies from 1550-1850°C.

**3. Reducing Zone** The reducing zone starts from the top of combustion zone and extends upto the bottom of the first metal charge. In this zone, the endothermic reaction of reducing  $\text{CO}_2$  to  $\text{CO}$  is taking place



This reduces the heat in the zone and the temperature in the zone is around 1200°C only.

**4. Melting Zone** Melting Zone starts with the first layer of the metal charge and extends upto 90 cm or less. The metal charge melts in this zone and moves down to the well. The temperature of this zone is around 1600°C and the following reaction which adds up the carbon content of molten metal takes place.



**5. Preheating Zone** Preheating zone starts from the top of the melting zone and extends upto the charging door. The charge in this zone is preheated by the hot gases such as  $\text{CO}_2$ ,  $\text{CO}$  and  $\text{N}_2$  moving upwards from the combustion and reducing zones.

**6. Stack Zone** Stack zone extends from the end of preheating zone to the end of cupola shell and includes the spark arrester. Hot gases from the cupola pass through the stack zone and escape to the atmosphere through the spark arrester.

## 1.13 CRUCIBLE FURNACE

The Crucible Furnace is used to melt non-ferrous metals like Brass, Bronze, Aluminium, etc. The crucible process is the oldest process for melting metals. Crucibles are usually

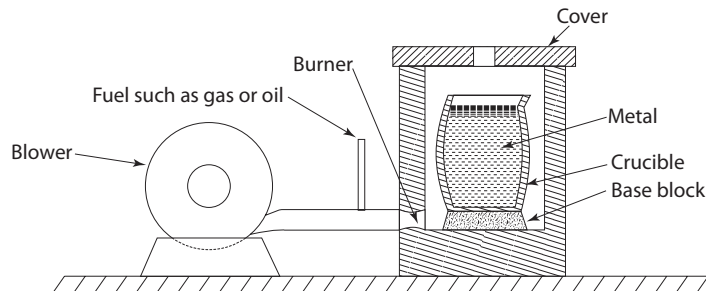


made of a mixture of graphite and clay. They possess greater strength when they are heated. The material to be melted is placed inside the crucible and they are heated with coke or oil as fuel. The molten metal can be transferred to a ladle. The two types of crucible furnace are explained below.

### 1.13.1 Non-Tilting Crucible Furnace

This is also called as stationary type crucible furnace. The non-tilting type furnace is used for melting a small amount of metal. The schematic diagram of non-tilting type furnace is shown in Fig. 1.22.

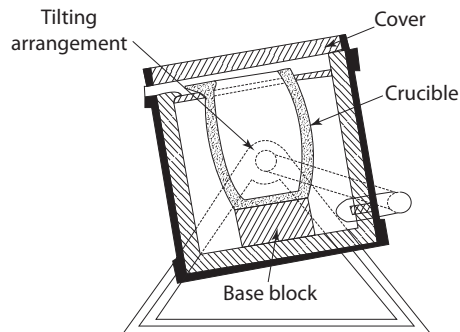
The advantage of non-tilting type crucible furnace is that no preheated ladle is necessary. A blower is used in the crucible furnace which supplies me primary air for combustion.



**Fig. 1.22** *Non-tilting type crucible furnace*

### 1.13.2 Tilting Type Crucible Furnace

The tilting type crucible furnace is used to melt larger amounts of metal. When the molten metal is ready to be poured, the furnace is tilted and transferred to a preheated ladle. A preheated ladle is used to reduce the undesirable drop of metal temperature. The schematic representation of a tilting type crucible furnace is shown in Fig. 1.23.



**Fig. 1.23** *Tilting type crucible furnace*

## 1.14 FETTLING

Fettling is the process of cleaning and finishing a casting. This includes the removal of cores, sand and oxide scale from the surface of a casting, gates risers, runners and other unwanted projections from the casting.

## 1.15 CASTING DEFECTS

The most common type of defects in casting are as follows:

**Blow Holes** Blow holes are cavities present inside the casting or on the surface of the casting. They are caused by the entrapped gases or steam in the casting. Because of molten metal, gases are generated and the moisture present in the moulding sand accounts for the steam. For avoiding blow holes, proper venting should be provided. Also the presence of gas producing ingredients in moulding sand should be avoided and the permeability of the moulding sand should be high. Due to low moisture content, blow holes will be considerably less in dry sand and skin dried moulding, compared to green sand moulding. The blow holes occurring on the surface are called open blows.

**Pin Holes** Pin holes are large number of small holes occurring on the surface of the casting. This is caused by hydrogen or carbon monoxide picked up by the molten metal in the furnace or while transferring it for pouring. When the metal gets solidified, the solubility of these gases decreases. Hence, these gases are expelled out of the casting and during this process, these leave a number of small holes.

**Swell** A swell is an enlargement of the mould cavity because of the pressure exerted by the molten metal. This causes some error in the dimensions of the casting. This can be avoided by a proper ramming of the moulding sand.

**Shrinkage Cavity** Shrinkage cavity is a void or depression caused by shrinkage of the metal. This may be avoided by adequate risers and by proper mould design.

**Shift** A shift is caused when there is mismatch of the sections of a casting usually at parting line. This can be avoided by proper alignment of the pattern, moulding boxes, etc.

**Drops** Drop is caused by the falling of some loose moulding sand from the cope surface of the mould into the mould cavity. This leads to unwanted projections or cavities in the castings. This can be avoided by proper ramming and by using moulding sand having high green strength.

**Misruns** Misruns are caused by the incomplete filling of the mould cavity by the molten metal. This leads to unfilled cavities in the casting. This defect can be avoided by having an increased fluidity of the metal and by avoiding the small thickness of the casting.

**Cold Shuts** A cold shut is caused by incomplete fusion of the molten metal stream while meeting in the mould cavity. This leads to a discontinuity or a weak spot in the casting.

This can be avoided by having increased fluidity of the metal and by avoiding too small thickness of the casting.

**Runout** A runout is caused by the leakage of the molten metal out of the mould cavity. This leads to unwanted projections in the casting. This can be avoided by proper ramming while making the mould.

**Metal Penetration** A metal penetration is caused by the entering of molten metal into the space between the grains of the moulding sand. This can be avoided by using moulding sands having lower permeability and smaller grains.

## 1.16 INTRODUCTION TO METAL JOINING PROCESSES

Metal joining processes are manufacturing processes in which metal pieces are joined by the application of heat by some means. The various metal joining processes are welding, brazing and soldering.

These processes differ from each other in the temperature at which the joining is done. Welding involves heating the metals over a higher range of temperature up to fusion and then allowing it to cool. In case of brazing and soldering, the metals being joined are heated below their melting point.

## 1.17 WELDING

Welding is a metal joining process in which the joining of metals is done by the application of heat with or without the application of pressure. During welding, the edges of the metal pieces are heated over a higher range of temperature, i.e., these are either melted or brought to a plastic condition and then allowed to cool. Welding processes may be classified into many types based on the method in which the heat is applied. In arc welding, heat is applied by producing an electric arc between two conductors whereas in gas welding heat is applied by the combustion of a fuel gas with oxygen.

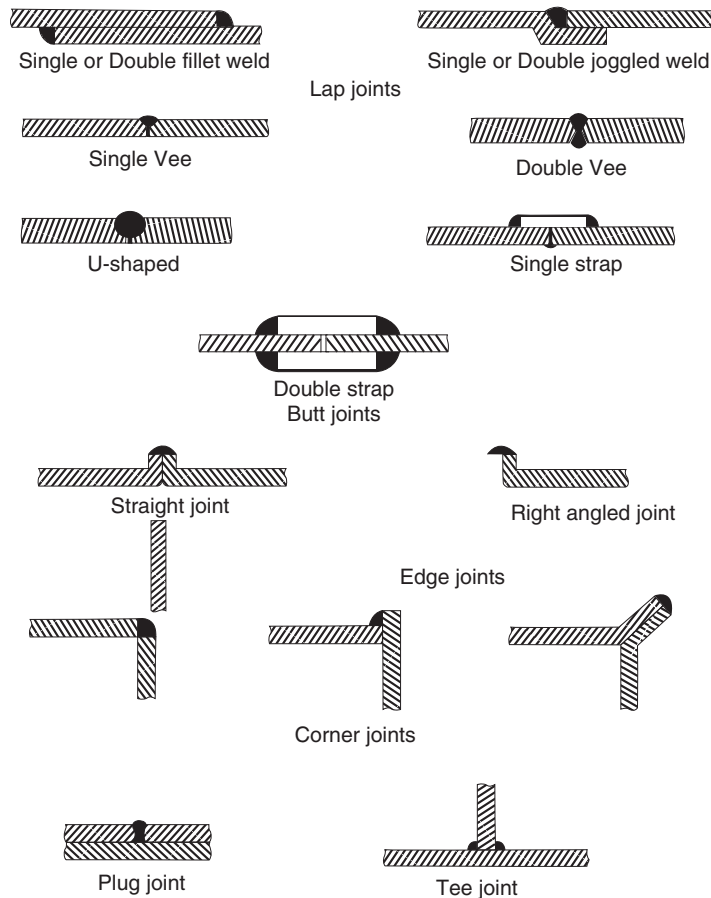
### 1.17.1 Types of Welded Joints

Welding may be done with or without the preparation of edges of the metal pieces. The following types of joints are used widely in welding processes:

1. Lap joints
  - (a) Single or double fillet weld
  - (b) Single or double joggled weld
2. Butt joints
  - (a) Single vee
  - (b) Double vee
  - (c) U-shaped
  - (d) Single strap
  - (e) Double strap

3. Edge joints
  - (a) Straight joint
  - (b) Right angled joint
4. Corner joints
5. Plug joint
6. Tee joint

The above mentioned joints are shown in Fig. 1.24.



**Fig. 1.24** *Types of welding joints*

### 1.17.2 Basic Welding Terms

One should be familiar with the several technical terms used in welding technology.

**Base Metal or Parent Metal** In welding, the metal to be joined is known as parent metal or base metal.

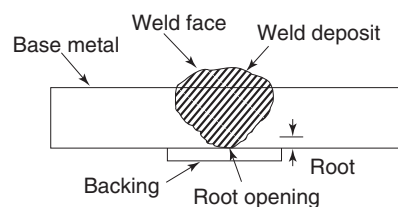
**Filler Metal** It is a metal or alloy used for filling the weld cavity. Filler metals usually have the same composition as that of the base metal. Sometimes, it may have some additional alloying element to strengthen the joint.

**Weld Metal** It is the metal that is solidified in the weld cavity. It may be only metal or a mixture of base metal and filler metal.

**Edge Preparation** It is the preparation of the edges of metal pieces to be joined into some forms depending on the thickness of the metal and types of welded joints.

**Root** It is the narrow region at the bottom of the welded joint, shown in Fig. 1.25. The gap between the metal pieces at the root region is called root opening.

**Weld Pass** A single movement of the welding torch or electrode along the length of the joint is called as a weld pass. Based on the thickness of the metal piece, welding can be completed in a single or multi-pass. The weld pass in the root region is called as a root pass and subsequent passes for filling the joint are called as filler passes.



**Fig. 1.25** Basic welding terms

**Penetration** The depth up to which the weld metal combines with parent metal is called metal penetration. It is measured from the top surface of the joint.

**Deposition Rate** It is the rate at which the weld metal deposits in the joint per unit time.

**Tack Welds** These are two small welds made at the end of the joint for temporarily holding the metal pieces.

**Backing** It is the metal support given below the root portion to control the penetration.

**Weld Face** It is the convex shape of the weld deposit.

## 1.18 ARC WELDING

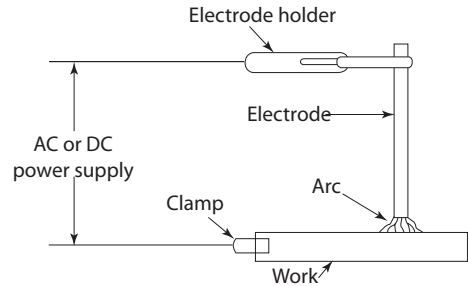
Arc welding is the process of joining two metal pieces by melting their edges with an electric arc. An arc is an electric discharge through the ionised gas column between two conductors of electricity namely the cathode and the anode. When two conductors are touched and then separated by a small distance, electrons are liberated from the cathode and move towards the anode. Also, the positively charged ions move from the anode towards the cathode. The impact of these electrons and positive ions at high velocity onto the conductors liberates heat. The temperature of the arc is about 3870°C.

An arc useful for generating heat can be obtained between an electrode and the work piece, between two electrodes and also between two metal pieces to be welded.

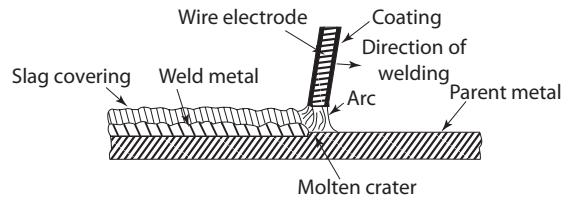
Figure 1.26 shows a schematic arrangement of an arc welding equipment. An alternating current or a direct current source can be used for arc welding process. In direct current arc welding, two types are possible. When the electrode is connected to the negative terminal

of the power source and work piece to the positive terminal, it is called direct Current Straight Polarity (DCSP) arc welding. If the electrode is connected to the positive terminal of the power source and the work piece to the negative terminal, it is called as Direct Current Reverse Polarity (DCRP) welding. Direct current arc welding power sources are usually d.c. generators, whereas in the case of alternate current arc welding, the power sources are transformers.

The electrode is held by means of an electrode holder and the work pieces are kept on a metal work table. The electrode holder and the metal work table are connected to different terminals of the welding power source by means of long insulated cables. Initially, the metal work piece is touched with the electrode and then separated leaving a small gap between the electrode tip and the work piece. In arc welding, the gap between the electrode and the work piece is important for the arc to exist continuously and it is known as the arc length. This has to be maintained within a specified range for good quality welding. Once the arc has been initiated, the electrode is moved along the length for completing the welding process, as shown in Fig. 1.27.



**Fig. 1.26** Arc welding circuit



**Fig. 1.27** Arc welding

### 1.18.1 Electrodes

Electrodes used in arc welding may be a consumable or a non-consumable electrode. A consumable electrode is used to produce an arc and is also melted to fill the weld cavity, i.e. it also serves as a filler metal. A non-consumable electrode is used only for producing an electric arc.

Electrodes may be bare, flux coated or heavy coated. Bare electrodes are without any coatings on their surface and are widely used in automatic and semi-automatic welding.

Flux coated electrodes are coated with a thin layer of some chemical components, generally called as flux. This coating usually consists of lime mixed with soluble glass which serves as a binder.

Heavy coated electrodes are provided with thick flux coatings. Many chemicals are added in flux coating for getting some specific advantages. Common flux materials with their functions are given below:

Starch and wood pulp form a gas shield around the weld zone preventing it from atmospheric oxygen. China clay, felspar, manganese and titanium ores form a slag deposit over the molten weld metal, preventing contaminations due to atmospheric air and also ensures a uniform rate of cooling of the weld metal. Ferro-silicon, ferro-titanium

and ferro-manganese reduce the oxides which are likely to be formed in the weld metal. Sodium silicate, potassium silicate and asbestos serve as binding materials. The alloying components: aluminium, zirconium, nickel, chromium and molybdenum improve the strength of the joint. Other advantages of the coating materials are stabilised arc, increased deposition, improved arc penetration, facilitated over head welding and reduced spatter of weld metal.

### 1.19 GAS WELDING

Gas welding is the process of joining two metal pieces by melting their edges by a flame resulting from the burning of a gas fuel and oxygen. Oxygen acetylene combination is the most widely used in this process. The process using the above combination is called as oxy-acetylene welding. In gas welding, the flame is produced at the tip of a welding torch. It is used for heating the metal. A filler metal, in the form of a rod is added separately for filling the weld cavity. Gas welding is widely used for welding all ferrous and non-ferrous metals.

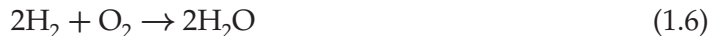
**Oxy-acetylene Welding** In oxy-acetylene welding, the flame is produced by burning a mixture of oxygen and acetylene. This mixture burns to produce the high flame temperature upto  $3480^{\circ}\text{C}$  in a two stage reaction.

In the first stage, oxygen and acetylene react to form carbon monoxide and hydrogen.



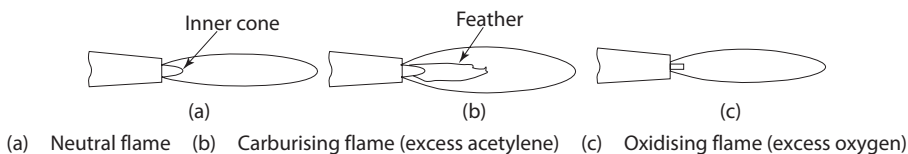
This reaction occurs near the end of the torch tip.

In the second stage, carbon monoxide and hydrogen react with oxygen forming carbon dioxide and water vapour respectively.



These reactions occur just after the first combustion zone. The oxygen for above two reactions is obtained from the atmosphere.

Based on the ratio of oxygen and acetylene in the mixture, the flame may be neutral, oxidizing or carburising flame. They are shown in Fig. 1.28 (a)-(c). A neutral flame is obtained by supplying equal volumes of oxygen and acetylene. The neutral flame has two sharply defined zones, one inner white cone flame and an outer blue flame envelope. Neutral flame is used for welding steel, stainless steel, cast iron and copper.

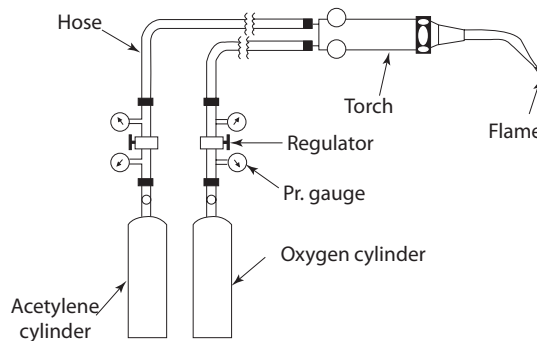


**Fig. 1.28** Types of gas flames

A carburising flame is obtained by supplying more volume of acetylene than oxygen. A carburising flame has the two sharply defined zones as in case of a neutral flame with the addition of a third zone, whitish in colour known as intermediate flame feather. The carburising flame is used for welding monel, low-carbon steels and some alloy steels.

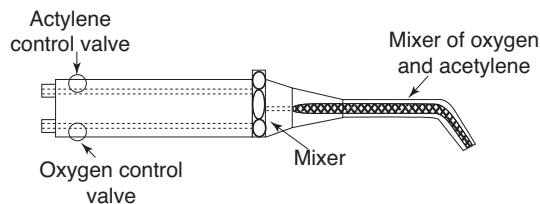
An oxidising flame is obtained by supplying more volume of oxygen than acetylene. The oxidising flame is similar to neutral flame with two distinct zones. But, the inner white zone is much smaller than that of a neutral flame. Oxidising flame is used for welding copper and copper alloys.

Figure 1.29 shows a schematic view of the equipment used for oxyacetylene welding. In this, oxygen and acetylene are to be supplied at a specified pressure range only. Hence, the gas cylinders are provided with pressure gauges and pressure regulators. Oxygen and acetylene flow to the welding torch through separate rubber hoses.



**Fig. 1.29** *Oxy-acetylene welding circuit*

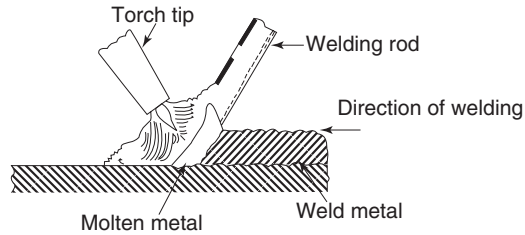
Figure 1.30 shows cross section of a welding torch. The welding torch mixes oxygen and acetylene in the desired proportions and burns the mixture at the tip. This can be achieved by means of control valve for oxygen and acetylene and a well designed mixer.



**Fig. 1.30** *Welding torch*

Initially, the acetylene is supplied and it is ignited with a friction spark lighter. After this, oxygen is supplied with the help of a separate valve and the nature of the flame is adjusted. A filler metal in the form of a rod is held in the flame and is melted to fill the weld cavity as shown in Fig. 1.31.





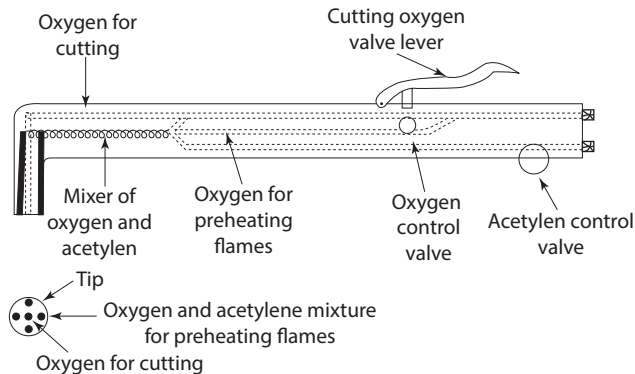
**Fig. 1.31** *Oxy-acetylene welding*

## 1.20 GAS CUTTING

Gas cutting is a process to cut ferrous metals and steels. The equipments used for this process is similar to that of oxy-acetylene welding except for the torch. The cutting torch differs from the welding torch in that it has several small holes for the oxygen-acetylene mixture, surrounding a central hole for pure oxygen. The sectional view can be seen in Fig. 1.32. This oxygen-acetylene mixture through the small holes is used for preheating the metal to be cut. For ferrous metals, the cutting process is the rapid oxidation at high temperature.



But, this reaction occurs at high temperature approximately at about  $870^\circ\text{C}$ . Hence, the preheating flame is first used to raise the temperature. Then a stream of pure oxygen is added to the torch which oxidises the iron and also expels the liquid iron oxide from the joint. This process gives economic and accurate cuts.



**Fig. 1.32** *Oxy-acetylene cutting torch*

## 1.21 BRAZING

Brazing is a metal joining process which is done by the use of heat and a filler metal whose melting temperature is above  $450^\circ\text{C}$  but below the melting point of the metals being joined.

Brazing differs from welding in the following ways:

1. The composition of the filler metal or alloy (brazing metal) is different from the base metal.
2. The strength of the brazing alloy is lower than that of the base metal.
3. The melting point of the brazing alloy is lower than that of the base metal. So, the base metal is not melted during brazing.
4. Bonding requires the capillary action in brazing.

Brazing requires a clean surface, proper clearance between metals, good wetting of the joint and good fluidity for the brazing alloy in the joint.

### 1.21.1 Brazing Metals

The most commonly used brazing metals are copper and copper alloys, silver and silver alloys and aluminium alloys.

### 1.21.2 Purpose of Fluxes

Fluxes are some chemical compounds which are added into the brazing joints for the purpose of:

1. Dissolving oxides present on the surface of base metals.
2. Preventing the formation of oxides during heating.
3. Lowering the surface tension of the molten brazing metal and thus promoting its flow into the joint.

Most commonly used brazing flux is borax. However, metallic halide salts such as sodium and potassium chlorides are used to braze aluminium.

### 1.21.3 Brazing Methods

A general brazing method involves the following:

1. Cleaning of the joint and setting proper clearance between the metals.
2. Applying flux to the joint.
3. Heating the joint to bring it to the liquidous temperature of the brazing alloy.
4. Applying the brazing metals so that it flows into the joint by capillary action. The brazing metal may also be pre-placed in the joint.

The brazing metal on solidification gives the necessary joint strength. Based on the method adopted for heating, brazing can be classified into various types. The following methods are commonly used.

**1. Torch Brazing** In torch brazing, the source of heat for brazing is a gas flame torch. It may be oxy-hydrogen or other gas flames.

**2. Dip Brazing** In dip brazing, the pre-assembled metal joints are dipped in a bath of molten brazing metal. The molten brazing metal bath provides both the required heat and the brazing metal for the joint. It is usually adopted for a small part.

**3. Salt Brazing** In salt brazing, the assembled parts are dipped in a bath of molten salt kept at a temperature slightly above the melting point of the brazing metal. The brazing metals are preplaced in the joint and the molten salt bath provides the heat to melt them.

**4. Furnace Brazing** In furnace brazing, the assembled metal joints with preplaced brazing metals are kept in controlled atmosphere or vacuum furnaces. Because of the easy control of brazing temperature and as no skilled labour is required, furnace brazing is used for mass production.

**5. Induction Brazing** In induction brazing, high frequency induction current is used for heating the joints. Induction brazing requires simple heating coil which should fit around the joint to provide the heating at the required area. The brazing metal is preplaced in the metal joint.

**6. Resistance Brazing** In resistance brazing, the metals to be joined are held under pressure between two electrodes. The heating is due to the electric resistance between the electrodes when electric current is passed through them.

#### 1.21.4 Braze Welding

Braze welding differs from the general brazing process in that the capillary action is not used to fill the joints by the filler metal. Here, the filler metal fills the metal joint by gravity as in some welding processes. Mostly, braze welding is done with an oxy-acetylene torch.

### 1.22 SOLDERING

Soldering is a metal joining process in which the joining of metal is done by the use of heat and a filler metal whose melting temperature is below 450°C.

Joint strength is relatively low in case of soldering and the joining is due to adhesion between the filler metal called the solder and the parent metal.

#### 1.22.1 Solder Metals

Most solders are alloys of lead and tin with a little amount of antimony (less than 0.5%). However, tin-antimony alloys are used in electrical applications. Tin-Zinc, cadmium-zinc or aluminium-zinc or cadmium silver alloys are used for high temperature service.

#### 1.22.2 Soldering Fluxes

Soldering fluxes are classified as corrosive and non-corrosive fluxes. The most commonly used corrosive fluxes are muriatic acid and a mixture of zinc and ammonium chlorides. A common non-corrosive flux is rosin in alcohol.

### 1.22.3 Soldering Methods

It is similar to that of brazing. Here the flux used is not intended to remove any appreciable amount of contamination. Hence, the surface has to be cleaned to remove all dirt, oil and grease before the flux is applied.

As in brazing, soldering may also be classified into various types based on the methods adopted for heating the joints. Dip soldering is used extensively for soldering electronic appliances. Induction soldering is used for large number of identical parts. In iron soldering, electric soldering iron is the commonly used heat source. In case of low melting point solders, infra-red heat source can be used which is called as infra red soldering.

### 1.22.4 Flux Removal in Brazing and Soldering

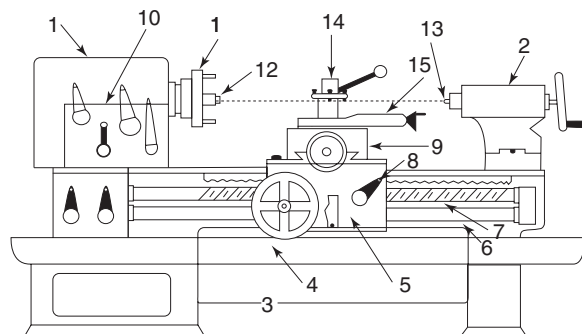
Some fluxes used in brazing and soldering are corrosive. So, the flux residues must be completely removed for preventing corrosion in joints. Water soluble fluxes are removed with hot water. Alcohol or grease can also be used as solvents for flux removal.

## 1.23 LATHE

Lathe is one of the oldest and most important machine tools. The lathe has become a general purpose machine tool which is used widely in production works. It removes the excess material from the work piece by rotating it against a cutting tool. The tools can be fed deep through the excess material on the work piece. The job is held between rigid supports.

### 1.23.1 Main Parts of a Lathe

The main parts of a central lathe are given in Fig. 1.33.



- |               |                   |                   |
|---------------|-------------------|-------------------|
| 1. Head stock | 6. Feed shaft     | 11. Driving plate |
| 2. Tail stock | 7. Lead screw     | 12. Live centre   |
| 3. Leg/Bed    | 8. Half-nut lever | 13. Dead centre   |
| 4. Tray       | 9. Cross-slide    | 14. Tool post     |
| 5. Carriage   | 10. Gear box      | 15. Compound rest |

**Fig. 1.33** Centre lathe

**1. Bed** The bed is the basic structure of the lathe and constitutes 70-90 percent of the total weight of the lathe. All other parts are fitted on to this bed. Two sets of parallel, longitudinal guideways are contained on the bed's upper surface. These guideways are precision machined to ensure accurate alignments of other parts fitted on the bed. It is made strong enough to resist the deflections and vibrations due to cutting forces. The bed is usually made of cast iron or nickel cast iron alloy.

**2. Head Stock** The head stock is mounted at the left end of the bed. It provides the power required for rotating the work at various speeds and for the tool movement as well. The head stock receives the drive from an electrical motor and it makes use of the cone pulleys and gears for getting various spindle speeds. There are speed change levers on the head stock for this purpose. The head stock also contains work holding devices such as chucks, face plates and dog plates on it. The head stock mounts the live centre.

**3. Tail Stock** The tail stock is mounted at the right end of the bed. It mounts the dead centre. It can be moved along the lathe bed for accommodating work pieces of different sizes. It is mainly used for the following purposes:

- (a) To support one end of a long work piece
- (b) To hold a tool for the operations like drilling, reaming, tapping, etc.

**4. Carriage** The carriage provides the means for mounting and moving the cutting tools. The carriage has the following parts:

- (a) *The saddle:* It is H-shaped casting fitted onto the bed and moves along the outer set of guideways on the bed surface.
- (b) *The cross slide:* It is mounted on a transverse bar on the saddle and can be moved by means of the feed screw that is controlled by a small hand wheel. The cross slide is used to move the cutting tool along a perpendicular direction to the axis of rotation of the work piece.
- (c) *The compound rest:* It consists of a base, which is mounted on the cross slide and an upper casting. The base is graduated in angle for swivel of the compound rest through any angle. The upper casting is mounted on guide ways on the base. It can be moved along the guide ways by a hand wheel.
- (d) *The tool post:* It is mounted on the compound rest. The cutting tool is clamped in the tool post.
- (e) *The Apron:* It is attached to the front of the carriage. It contains the mechanism for the manual and automatic motion of the carriage and the cross slide. For the manual movement of the carriage along the bed, there is a hand wheel on the front of the apron. The hand wheel shaft has a pinion at its other end which engages with a rack attached to the bed.

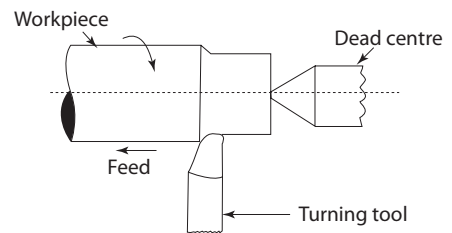
**5. Feed Mechanism** The power is transmitted to the apron through the feed mechanism. It is located at the left of the bed. Power is transmitted to the apron by a rotating feed rod through the gearing and clutch arrangement in the apron.

For cutting threads, the drive is given by a lead screw by a direct connection between the apron and the lead screw by means of a split nut.

### 1.23.2 Important Operations Done on a Lathe

**1. Turning** Turning is a lathe operation in which the diameter of cylindrical jobs is reduced to the desired dimensions. In turning, the work piece is held between the lathe centres or in a chuck. The tool is clamped in the tool post.

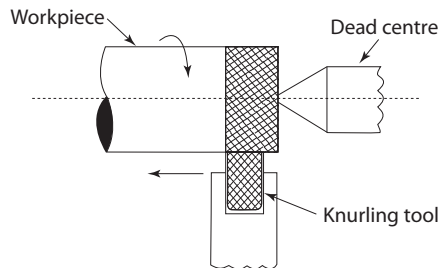
The work piece is rotated and tool is fed parallel to the axis of rotation, as shown in Fig. 1.34. Turning operation resulting in the same diameter over the full length of the work piece is called straight turning and when different diameters are obtained, it is called step-turning or shoulder turning.



**Fig. 1.34** Turning

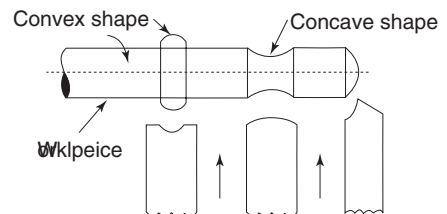
**2. Knurling** In knurling, the surface of the work piece is made rough for easy gripping as shown in Fig. 1.35.

The knurling tool consists of two or more hardened steel rollers which have diamond patterns on their surface. These patterns are formed on the surface of the work piece by pressing the knurling tool against the rotating work piece.



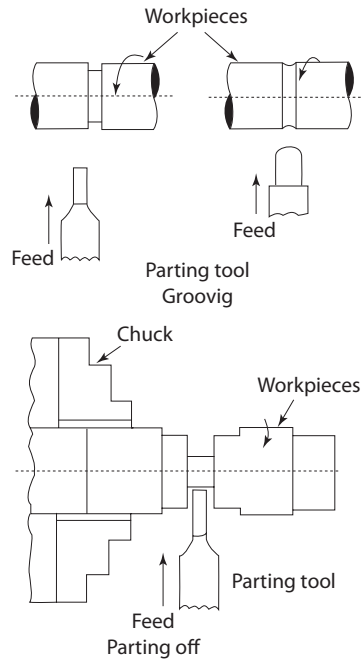
**Fig. 1.35** Knurling

**3. Forming** The required profile is obtained by pressing a form tool against the surface of the rotating work piece. Forming can produce concave, convex or any irregular shape as shown in Fig. 1.36.



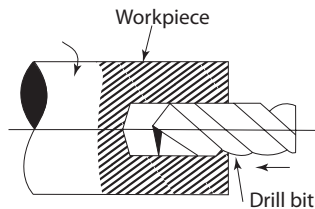
**Fig. 1.36** Form turning

**4. Grooving and Parting Off** Grooving is the operation by which some grooves or neckings are produced on the work piece as shown in Fig. 1.37. Parting off is the operation by which one section of a work piece is cut or parted off from the remainder by means of a parting off tool. The tools used for this are thin as shown in the Fig. 1.37. Both the above operations are done by feeding the tool into the work piece at a proper and uniform rate.



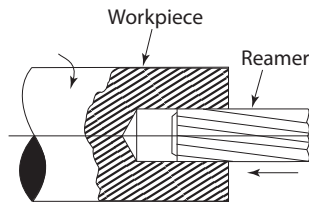
**Fig. 1.37** Grooving and parting-off

**5. Drilling** Drilling is the operation by which a hole is produced in the work piece. For drilling, the work piece is rotated by holding in a chuck while the drilling tool is held in the tail stock and fed into the work piece. This can be seen in Fig. 1.38.



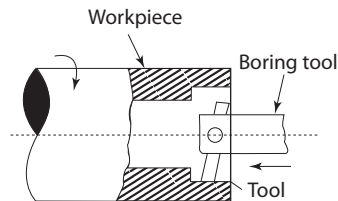
**Fig. 1.38** Drilling

**6. Reaming** Reaming is the operation by which the dimension of a drilled hole is corrected. This is similar to drilling, but the reaming is more accurate and involves very little metal removal. The reaming operation is shown in Fig. 1.39.



**Fig 1.39** *Reaming*

**7. Boring** Boring is the operation by which a drilled hole is enlarged. For boring, the work piece is rotated by holding in a chuck and the boring tool fitted on the tool post is fed into the work piece for enlarging the holes drilled which can be seen in Fig. 1.40. If the enlarging is done only through some length of the work piece, it is called counter boring as given in Fig. 1.40.

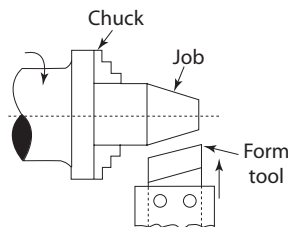


**Fig. 1.40** *Counter boring*

**8. Taper Turning** Taper turning is the operation by which the tapered surface is produced on the work piece.

For taper turning, any one of the following methods can be adopted:

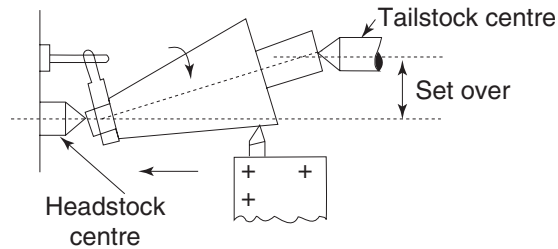
(a) By using a form tool as in Fig. 1.41.



**Fig. 1.41** *Taper turning by a form tool*

(b) By tail stock set over method as in Fig. 1.42.

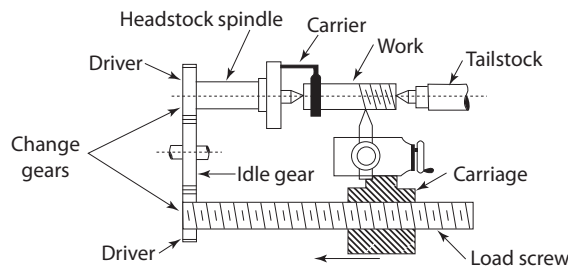




**Fig. 1.42** Taper turning by tail stock set over

**9. Thread Cutting** Thread cutting is the operation by which threads are formed on the surface of the work piece.

Thread cutting on a lathe is done by making use of a special arrangement in the carriage and the lead screw. The special arrangement is the half nut which can be engaged with the lead screw as shown in Fig. 1.43. This engagement makes the cutting tool to move through distance equal to one pitch of the thread for one revolution of the work piece. For obtaining different pitches on the work, the speed of the lead screw is changed by engaging proper change gears between the head stock spindle and the lead screw.



**Fig. 1.43** Thread cutting

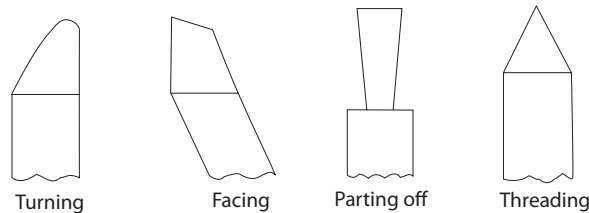
The change gear may be selected by the following calculation:

$$\frac{\text{Number of teeth on the spindle gear}}{\text{Number of teeth on the lead screw}} = \frac{\text{Pitch of the thread to be cut}}{\text{Pitch of lead screw threads}}$$

### 1.23.3 Lathe Tools

Most of the lathe operations are done with simple and single point cutting tools. These tools slightly vary in their shapes according to the operations for which these are used. In case of turning tools and facing tools, the cutting takes place on the side of the tool. But, in the case of parting-off tools, finishing tools and thread cutting tools, cutting takes place on

or near the end of the tool. Various shapes of common single point lathe tools are shown in the Fig. 1.44 along with their uses.



**Fig. 1.44** Lathe tools

## 1.24 DRILLING MACHINES

In a drilling machine, holes are drilled by rotating a cutting tool called a drill. Drilling machines can also be used for other operations like boring, reaming, tapping, spot facing, etc.

### 1.24.1 Types of Drilling Machines

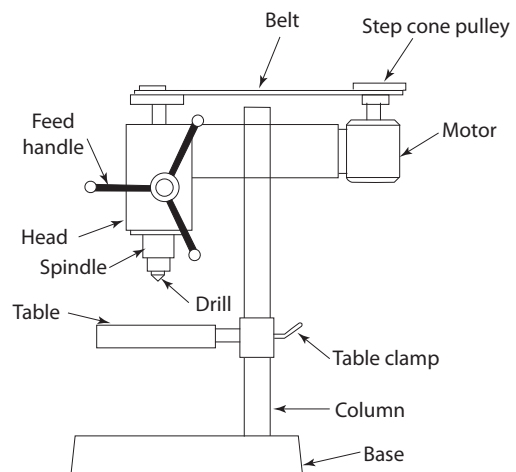
In this section, the different types of drilling machines are described:

**1. Portable Drilling Machine** Portable drilling machines are small compact machines which can be easily carried around. It has an in-built electric motor which rotates the drill at high speeds. It is specified by the maximum diameter of the hole that can be drilled. It is used for the jobs which cannot be taken to the drilling machines. It is also used for drilling small holes on large job at any desired angles.

**2. Sensitive Drilling Machine** It has a base on which a cylindrical post is mounted vertically. The cylindrical post is called the column of the drilling machine. A table is attached to the column by means of a table clamp. The table supports the work piece and work holding devices. It can be moved along the column for proper positioning of the work piece.

A spindle head and a drive mechanism are mounted at the top of the column. It has an electric motor which drives the spindle by means of a belt and cone pulley arrangement as shown in Fig. 1.45. Spindle speeds can be changed by shifting the belt from one pulley to another.

The drill is held by a proper holding device such as a drilling chuck attached to the spindle. The drill is fed into the work piece placed on the table by manually rotating the drill feed handle. This can be used to drill holes from 1-25 mm.



**Fig. 1.45** Sensitive drilling machine

## 1.25 AUTOMOBILE

To transport raw materials to the factory and finished products from the factory, we need sufficient facilities by providing long services.

For the convenience of workers and other staff, for their transport, we need some buses and cars, in case of a big industry.

Lorries and buses are driven by diesel engines while cars are driven by either petrol engines or diesel engines. Diesel cars are costlier than petrol cars. Types of internal combustion engines like 2 stroke and 4 stroke and details of their working including fuel systems, cooling system, lubrication system, etc. are given in another chapter 2 stroke petrol engines are used in all motor cycles.

In the USA, every house has more than one car. In 1956, I have driven in the 8 lane highway in Chicago and all the lanes were full. In spite of very heavy traffic, road accidents are very few, as the roads are good and all of them follow the traffic rules.

But, in India, road accidents and deaths are very heavy due to the following reasons:

1. Most of the roads are not good. So, the government should look into the matter and rectify the defects.
2. Drivers do not follow the traffic rules. They drive the vehicles, after consuming alcohol such people must be heavily punished. Scooter driver do not wear helmet, in most of the states. Only in Delhi, almost 100% of the drivers including the person in the rear seat wear helmet. They must be congratulated.

In Chapter 11, the topic “Internal Combustion Engine (IC Engine)” is presented. The chapter deals with the different types of engines, important parts, their working, cooling arrangements, lubrication and fuel systems.

## 1.26 ENERGY ENGINEERING

From the consumption pattern of various fossil fuel like natural gas, fuel oil, coal, etc., it has been estimated that petroleum products and coal are not going to last beyond 50–100 years, respectively. As a result, every country needs to develop technologies which make use of non-conventional sources of energy such as solar, wind, tidal, geothermal, ocean, thermal energy, etc. In India, we produce maximum electricity by wind mills.

In Chapter 8, the topic “Power Plant” is presented. The chapter deals with the different types of alternate sources of energy.

## 1.27 INTERDISCIPLINARY CONCEPTS IN CIVIL AND MECHANICAL ENGINEERING

One of the main functions of civil engineering is the construction of buildings. Mechanical engineering is mainly involved in production work in industries, for which they need large number of buildings which can be constructed by civil engineers.

For construction work, we need large amount of cement. Though civil engineers may buy from the market, it is manufactured by mechanical engineers in a cement factory.

Now-a-days, multistoried buildings are very common in all countries. In 1956, at New York, USA, I was thrilled to see very large number of multistoried buildings, including the Empire States building, the tallest in the world. For lifting building materials for the construction of such tall buildings, mechanical engineering comes to help.

One of the main functions of civil engineering is the construction of buildings. Mechanical engineering is mainly involved in production work in industries, for which they need large number of building, which can be constructed by civil engineers. For the construction of various types of industrial structures in pharmaceutical industry, food industry, paper industry, automobile industry, etc. civil engineers and different disciplines engineers like bio-medical engineers, chemical engineers, automobile engineers, biotech engineers, etc. work together.

Few examples are listed as follows:

1. Ventilation facilities especially in multi-storied building, fire safety in buildings and industries where civil, mechanical and fire safety engineers have to work together.
2. In health sector, doctors, health care officers, educationalists, municipal officers, taluk and district administrators have to interact with civil and mechanical Engineers for the construction of specialized hospitals and Educational Institutions. Construction of dust and microorganism free operation theatres, tissue banks, wards for patients of cancer and burns in hospitals demand great coordination.
3. Clean room constructions for the pharmaceutical industry, RandD centres, demand great coordination of civil and Bio-medical Engineers .
4. Few of the tough and large scale activities are construction of steel industry, paper industry, dams, bridges, tunnels, metal ores like iron, gold, etc. In which civil, mechanical and chemical engineers are required to coordinate.
5. In the transport sector, civil and mechanical engineers work together in executing facilities like roadways and railways.
6. For the construction of automobile industries, civil engineers require the coordination with mechanical and automobile engineers.
7. Marine engineers have to coordinate with civil and mechanical engineers for establishment of harbors, huge container handling cranes and naval structures.
8. Aeronautical and aerospace engineers have to interact with civil and mechanical engineers for the development of airports, aircraft manufacturing and rocket launching pads.
9. In food production, they work together in industries like fertilizers, production of pesticides, sugar industry, confectionary industries, to produce and preserve milk products like milk, cheese, butter, ghee, butter milk, milk powder, yogurt etc. Significant contributions are made in construction of the walk-in type of cold storages to preserve food materials where cooperation between civil and biotech engineers is needed.

10. Architects' and town planners' interaction with civil engineers is also essential for the infrastructure development, construction of energy conserving and environment friendly buildings. Recently, Government of India has planned many smart cities. Smart city concepts have great future to create safe living or work places. In this aspect, the cooperation of architects and civil engineers is needed.
11. The two engineering fields contribute tremendously, either to reduce the losses or for a quick recovery, at the time of natural or manmade calamities. Few of the techniques are listed as follows:
  - To reduce the chances of land slides in the hills, especially near the dams, concept of fixing cement concrete pivots on the sloping surfaces of a hill is used.
  - To reduce the possibilities of land erosion along the river beds articulated concrete blocks are used and in the coastal regions tetrahedral concrete structures are used.
  - Forest fires are brought under control with the help of equipment designed by civil and mechanical engineers.
  - Earthquake resisting foundations and buildings are available with the help of civil and mechanical engineering.
  - Building designs to resist or minimise the losses while encountering tsunami waves.
12. Infrastructure development includes suitable electric supply, Internet, telephones, good healthcare and therefore, civil engineers have to interact with electrical, communication and bio-medical engineering professionals.
13. Civil engineers and mechanical engineers coordinate with electrical engineers for the design, constructions and maintenance of the power plants like thermal power plant, hydro power plant, nuclear power plant and non-conventional power plants.
14. Constructions and maintenance of seawater desalination systems like Multi-Stage Flashing (MSF), Multi-Effect Desalination, Reverse Osmosis, or any other desalination plant where civil and mechanical engineers collaboration is required.
15. Software application is becoming more important and efficient in the project planning, estimation, analysis, design and stability of civil engineering structures and hence the role of software engineers in the civil engineering sectors becomes inevitable.

Thus, Civil Engineers should understand the importance of interdisciplinary approach in their planning, construction and erection activities to avoid criticism from any corner of the society. Though Civil and Mechanical Engineering professionals have their own systems in place in their fields, if other engineers play an interdisciplinary role, it will enhance values to their systems.

### Short-Answer Questions

(A) Answer the following briefly:

1. What is the scope of civil engineering?
2. What are the different branches of civil engineering?
3. Write short notes on building materials.
4. Write two functions of the construction management.
5. Why it is necessary to do structural analysis?
6. Write short notes on structural engineering
7. Why soil investigation is necessary?
8. What do you understand by the term foundation?
9. What do you mean by water resources engineering?
10. List the main objectives of a public water supply system.
11. List the various points to be considered in the planning of a water supply scheme for a town or city.
12. What are the sources of water?
13. What are infiltration galleries and infiltration wells?
14. What are springs and how are these formed?
15. Write the classification of wells.
16. Write the type of strainers used in tube wells.
17. What are the objectives of rainwater harvesting?
18. Write short notes on benefits of rainwater harvesting.
19. Differentiate between hydraulic engineering and irrigation engineering.
20. Define water supply engineering and sanitary engineering.
21. Write the importance of environmental engineering.
22. What is the object of surveying?
23. What do you mean by transportation engineering?
24. Write short notes on town planning and architecture.
25. List the facilities created due to infrastructure development.
26. Define Metal casting process.
27. List out commonly available foundry processes.
28. What are the advantages of metal casting process?
29. What is a pattern?
30. What are the pattern materials normally used in metal casting process?
31. What are the factors to be considered while selecting a pattern material?
32. What is meant by pattern allowances?
33. What are the purposes of providing pattern allowances?

34. Discuss the following as a pattern material.
  - (a) Wood
  - (b) Metals and alloys
  - (c) Plastics
  - (d) Wax.
35. List out various types of patterns
36. Write short notes on
  - (a) Draft allowance
  - (b) Shrinkage allowance
  - (c) Machining allowance
  - (d) Rapping allowance
  - (e) Distortion allowance.
37. Distinguish between solid pattern and split pattern.
38. What is moulding?
39. What are the basic ingredients of moulding sand?
40. Compare skeleton pattern and shell pattern.
41. List out the principal properties of moulding sand.
42. Define the following properties with respect to moulding sand.
  - (a) Refractiveness
  - (b) Collapsibility
  - (c) Strength
  - (d) Permeability
  - (e) Flowability
  - (f) Chemical resistivity
43. Compare cohesiveness and adhesiveness of the moulding sand.
44. Distinguish between
  - (a) Green sand and dry sand moulding
  - (b) Dry sand and skin dried sand moulding
  - (c) Loam sand and oil sand mould.
45. What are the various types of sand moulding methods?
46. What are the various tools used for hand moulding?
47. What is the importance of using cores in casting process?
48. What is the need of providing core print in a pattern?
49. What are the various types of furnaces available to melt metals and alloys?
50. What are tuyers? Explain their importance in a cupola furnace.
51. What is slag? How is it formed during the melting of cast iron in cupola furnace?
52. What are the various steps in the operation of cupola furnace?
53. What is meant by charging in a cupola furnace?

54. Distinguish between slag hole and tapping hole.
55. Mention the importance of spark arrester in a cupola furnace.
56. Enumerate the various zones in a cupola furnace.
57. Briefly explain the following in a cupola furnace.
  - (a) Well
  - (b) Superheating zone
  - (c) Preheating zone
  - (d) Melting zone
58. Briefly explain the following casting defects with cause and remedial methods.
  - (a) Blow holes
  - (b) Pin holes
  - (c) sand drop
  - (d) Swell
  - (e) shrinkage.
59. List out the most common defects of casting.
60. Compare the following defects
  - (a) Misrun and Cold shut
  - (b) Runout and Metal Penetration
61. What is fettling?
62. Enumerate the common methods to clean the castings.
63. Given the methods used to inspect castings.
64. Name the different metal joining processes?
65. Differentiate between Forge welding and Fusion welding.
66. What are the different flames obtained in Oxy-acetylene welding?
67. Give the importance of Edge preparation in Fusion welding.
68. What are the types of joints used in Fusion welding?
69. Give few examples for Fusion welding.
70. Give few examples for Forge welding.
71. Briefly explain the leftward and Rightward Techniques of welding.
72. What are the disadvantages of Gas welding?
73. List out various safety equipments used in welding.
74. What is the basic principle of Gas cutting?
75. How is the acetylene produced in acetylene cylinder?
76. Sketch the difference between Gas welding Torch Tip and Gas cutting Torch Tip.
77. What is the principle of soldering?
78. What are the types of solders used in soldering?



79. Differentiate between active flux and inactive flux in soldering.
80. What are the differences between brazing and soldering?
81. How does the borax flux prevent the base metal from atmosphere during brazing?
82. Briefly explain about
  - (a) Torch brazing
  - (b) Resistance brazing
  - (c) Induction brazing.

(B) Fill up the blanks with correct answers:

1. (a) The surface finish of casting are decided by sand \_\_\_\_\_.
- (b) Cushioning material added to the moulding sand for steel castings is \_\_\_\_\_.
2. (a) The economical method to produce cast iron is by \_\_\_\_\_ .
- (b) Flux used in cupola furnace is \_\_\_\_\_ .
3. \_\_\_\_\_ is used as flux in welding stainless steel.
4. For soldering electrical parts \_\_\_\_\_ flux is used.

(C) Choose the correct answer:

1. Pure metals can be melted using
  - (a) Cupola furnace
  - (b) Rotary furnace
  - (c) Induction furnace
  - (d) Crucible furnace.
2. Gas welding is a \_\_\_\_\_ process.
  - (a) Forge welding
  - (b) Fusion welding
  - (c) None of the above

(D) State whether the following statements are True or False:

1. Steel castings can be melted in coke fired furnaces. (True/False).
2. Filler rods used in the welding are made of the same base metal composition. (True/False)
3. Cast iron cannot be welded without flux (True/False)
4. Aluminium can be easily welded (True/False)

## Exercises

1. Explain any two branches of civil engineering.
2. Write a detailed report on building construction.
3. Describe briefly structural engineering.
4. Explain in detail geotechnical engineering.
5. Briefly explain environmental engineering.

6. Discuss the importance of water for the living beings.
7. Enumerate the various sources of water and discuss and compare the quality and quantity of water may be available from these sources.
8. Describe briefly the various sources of water available for water supply.
9. Enumerate the various forms in which groundwater occurs in nature. Describe briefly each of these forms.
10. Describe different components of rooftop rainwater harvesting.
11. Enumerate the methods of rooftop rainwater harvesting.
12. Explain the commonly used method of recharging groundwater aquifers.
13. Explain about the quality of water.
14. Describe about transportation engineering.
15. Write a detailed report on smart city development.
16. Explain the role of civil engineer.
17. What are the civil engineering infrastructure systems required for the socio-economical development of a country?
18. Explain briefly an overview of interdisciplinary concept of civil engineering.
19. Explain the civil engineering contributions in the welfare of the society.
20. Explain the interdisciplinary concepts in civil engineering.
21. Write a short note on patterns and material selection criterions.
22. List the dimensional allowances for patterns.
23. Draw neat diagrams of at least four pattern allowances and explain.
24. Draw neat diagrams of at least four patterns types and explain.
25. Write short note on the different mould sand properties and ingredients.
26. Explain how green sand mould is prepared.
27. With the help of a diagram, explain the purpose and working of a moulding machine.
28. Draw a neat diagram of and explain the working of a cupola furnace.
29. Discuss the various interdisciplinary concepts in Civil and Mechanical engineering.

## **UNIT-2**

# **SURVEYING AND SCOPE OF CIVIL ENGINEERING MATERIALS**



# Chapter 2

## **SURVEYING**

### **2.1 INTRODUCTION**

[Nov, Dec 2010, 2011]

Surveying is the art of determining the relative positions of distinctive features on the earth's surface. This is achieved by the measurement of distances, directions and elevations.

In general, surveying is limited to operations concerned with the representation of ground features in plan. A branch of surveying which deals with the measurement of the relative heights of the features is known as levelling.

### **2.2 IMPORTANCE OF SURVEYING**

The knowledge of surveying is advantageous in many phases of engineering. Every engineering project such as water supply and irrigation schemes, rail roads and transmission lines, mines bridges and buildings etc require surveys. Before plans and estimates are prepared, boundaries should be determined and the topography of the site should be ascertained. After the plans are made, the structures must be stated out on the ground. As the work progresses, lines and grades must be given.

### **2.3 OBJECTIVES OF SURVEYING**

The main object of any survey is the preparation of a plan or a map showing all the features of the area under consideration. A plan may be defined as a projection of the ground and the features upon it on a horizontal plane. So, a plan is the representation to some scale of the area and the objects contained in it. The representation is called a map if the scale adopted is small, while it is called a plan if the scale is large. For example, a map of India, a plan of a building.

### **2.4 TYPES OF SURVEYING**

[Nov, Dec 2010]

The surveying may be primarily divided into two types: plane surveying and geodetic surveying.

### 2.4.1 Plane Surveying

[May, June 2009; Nov, Dec 2010]

The surveying in which earth surface is assumed as a plane and the curvature of the earth is ignored is known as *plane surveying*. As the plane survey extends only over small areas, the line connecting two points on the earth is considered as a straight line and the angle between any two lines is considered as plane angle.

Surveys covering an area up to 260 km<sup>2</sup> may be treated as plane surveys. Such plane surveys are carried out for engineering projects and for geographical, geological, navigational and military purposes.

Plane surveys are used for the layout of highways, railways, canals, construction of bridges, dams, buildings, etc. The scope and use of plane surveying is wide. In order to have proper, economical and accurate planning of projects plane surveys are basically needed.

### 2.4.2 Geodetic Surveying

[Nov, Dec 2010]

The surface of the earth is not plane but spheroidal. Therefore, the line connecting any two points on the earth's surface is not a straight line but a curve.

The surveying in which curvature of the earth is taken into account for all measurements is known as *geodetic surveying*.

The result obtained from the above surveying will possess a high degree of accuracy as it considers the effect of curvature of the earth also. This surveying extends over large areas and so any line connecting two points on the earth's surface is considered as an arc. The angle between any two such arcs is treated as a spherical angle. To undertake this method of surveying, a through knowledge in spherical trigonometry is required.

Geodetic surveys need sophisticated instruments and accurate methods of observations. In order to eliminate the errors in observations due to atmospheric refraction, angular observations are generally taken only in nights and arc lamps are used as signals on survey stations.

In India, geodetic surveys are carried out by the Department of the Survey of India under the direction of the Surveyor General of India.

## 2.5 CLASSIFICATION OF SURVEYS

Depending on the use and the purpose of the finished work, surveys are classified under the following heads:

### 1. Classification Based Upon the Nature of the Field

#### (a) Land surveying

- (i) Topographical surveys To locate horizontal and vertical points by linear and angular measurements. For determining the natural features of a country such as streams, lakes, forests etc., and artificial features such as roads, railways, canals, towns & villages etc.

- (ii) **Cadastral surveys** Cadastral surveys are made incident to the fixing of property lines, the calculation of land area, or the transfer of land property from one owner to another. It is also done to fix the boundaries of municipalities and of state & federal jurisdictions.
- (iii) **City surveying** City surveying is done in connection with the construction of streets, water supply systems, sewers and other works.
- (b) **Marine (or) hydrographic surveys** It deals with the bodies of water for purpose of navigation, water supply, harbour works or for the determination of mean sea level. The work consist in measurement of discharge of streams, making topography survey of shores and banks, taking and locating soundings to determine the depth of water and observing the fluctuations of the ocean tide.
- (c) **Astronomical survey** It offers the surveyor means of determining the absolute locations of any point or the absolute location and direction of any line on the surface of the earth. This consists of observation of heavenly bodies such as sun or any fixed star.

## 2. Classification Based Upon the Objective of Survey

[Nov, Dec 2010]

- (a) **Engineering surveys** These are carried out for the determination of quantities which will be useful for the designing of engineering works.
- (b) **Military or defence surveys** These are carried out for the preparation of maps of important military areas.
- (c) **Geological surveys** These are carried out to ascertain the composition of the earth's crust.
- (d) **Mine surveys** These are conducted for exploring the mineral wealth below the earth surface.
- (e) **Archaeological surveys** These are executed to prepare maps of ancient cultures.

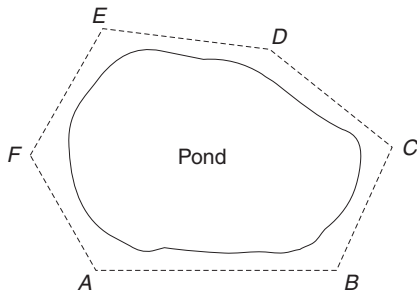
## 3. Classification Based Upon Methods Employed

- (a) **Triangulation surveys**
- (b) **Traverse surveys**

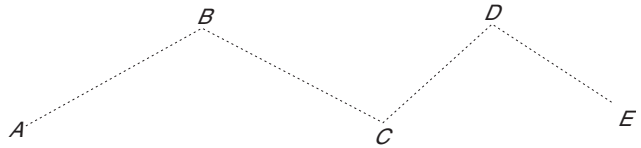
The framework in traverse survey consists of series of connected lines. The lengths and directions of these lines are measured with a chain or tape and with an angular measurement respectively.

A traverse is divided into two categories: *closed traverse normal open traverse*. A description of the two types of traverse is provided in this section.

1. **Closed Traverse** A traverse is said to be closed if a complete circuit is made, i.e. the origin and end point are one and the same thereby the circuit forms a closed polygon. This is particularly suitable for locating a building, boundaries of lakes, wooded lands, etc. A closed traverse is shown in Fig. 2.1.



**Fig. 2.1** *Closed traverse*



**Fig. 2.2** *Open traverse*

2. Open Traverse A traverse is said to be open if it does not form a closed polygon. It consists of a series of survey lines extending in one general direction but never returning to the starting point as shown in Fig. 2.2.

#### 4. Classification Based Upon the Instruments Used [May, June 2009, 2011; Nov, Dec 2012]

- (a) Chain surveying
- (b) Compass surveying
- (c) Plane table surveying
- (d) Theodolite surveying
- (e) Tacheometric surveying
- (f) Aerial surveying
- (g) Photographic surveying

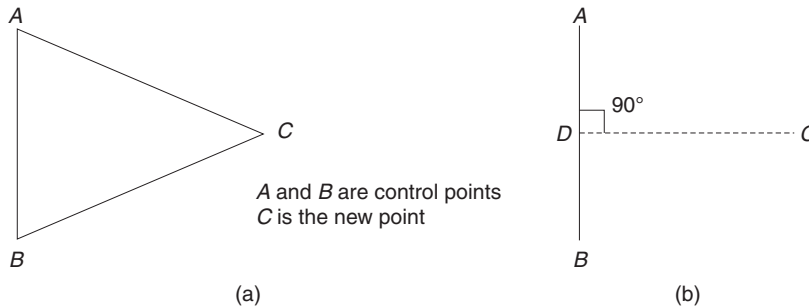
#### 2.6 PRINCIPLES OF SURVEYING [May, June 2009, 2010; Nov, Dec 2009; Apr, May 2015]

The two main principles of surveying are (i) working from the whole to the part, and (ii) fixing new points by at least two independent processes.

**1. Working from the whole to the part** Whether it is a plane surveyor or a geodetic survey, the main principle adopted is to work from the whole to the part. In the case of surveying of extensive areas, such as a town or a big estate, the survey is started by establishing a system of control points with high precision. The line joining these points will form the boundary lines of the area, otherwise, this is the main skeleton of the survey. The above control points may be established by triangulation or by running a traverse surrounding the area. The main triangles and traverses are then broken into smaller ones and measured using less laborious methods. The main reason to work from the whole to the part is to avoid the accumulation of errors and to control any localised errors. If, on the other hand, the survey is carried out from the part to the whole, the errors will be magnified in each and every step and will become uncontrollable at the end. The above principle is also fit to the levelling also.



**2. Fixing new points by at least two independent processes** The use of two independent processes to fix a new point, helps in taking one set of measurements from one process and the same may be checked by another set of measurements. The above is explained by the following two techniques as indicated in Fig. 2.3 (a) and Fig. 2.3 (b).



**Fig. 2.3** Fixing of points

Let  $A$  and  $B$  be the two given control points established by triangulation. Then, to fix the position of the point  $C$ ,

- the distance  $AC$  and  $BC$  may be measured and the position of  $C$  may be fixed by drawing the arcs; or
- by dropping a perpendicular from  $C$  to the base line  $AB$ . Here, the distance  $CD$  and  $90^\circ$  angle of intersection are the two different measurements made to locate  $C$ .

## 2.7 MEASUREMENT OF DISTANCES

The two main methods of determining the distances between two points on the surface of the earth are the direct method and the computative method. In the case of the direct method, distances are measured using tapes, chains, etc. In the latter case, distances are obtained by calculation using tacheometry, triangulation, etc.

### 2.7.1 Different Methods of Direct Measurements

Following are the methods of measuring the distances directly:

- pacing
- measurement with passometer
- measurement with pedometer
- measurement by odometer and speedometer
- chaining

**Pacing**

Measurements of distances by pacing are chiefly confined to the preliminary surveys and explorations where a surveyor is called upon to make a rough survey as quickly as possible. This method consists in counting the number of paces between the two points of a line. A length of pace more nearly to that of one's natural step is preferable.

**Passometer**

It is an instrument, shaped like a watch and is carried in pocket or attached to one leg. The mechanism of the instrument is operated by motion of the body and it automatically registers the number of paces. Then it can be multiplied by the average length of the pace to get the distance.

**Pedometer**

It is similar to the passometer except that it is adjusted to the length of the pace of the person carrying it. It registers the total distance covered by any number of paces.

**Odometer and Speedometer**

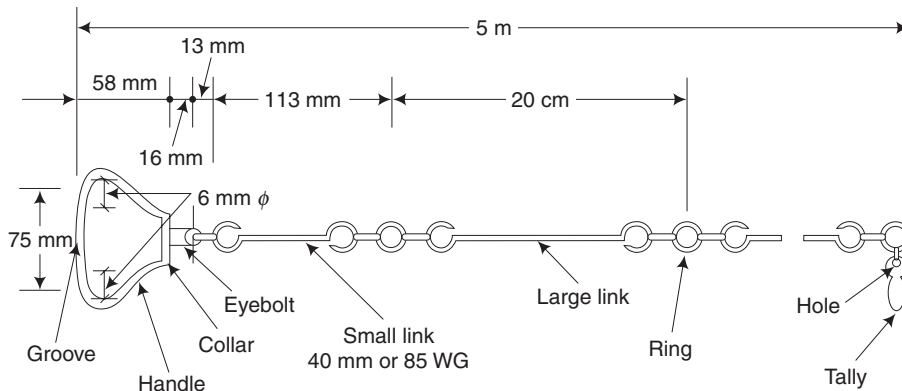
Odometer is an instrument for registering the number of revolutions of a wheel. The odometer is fitted to a wheel which is rolled along the line whose length is required. The number of revolutions registered by the odometer can be multiplied by the circumference of the wheel to get the distance.

**Chaining****[May, June 2012]**

Chaining is a term which is used to denote measuring distance either with the help of a chain or a tape and is the most accurate method of making direct measurements.

**2.7.2 Chain****[May, June 2012, 2013]**

The chain is generally composed of 100 or 150 links. The links are formed by pieces of galvanised loops and connected together by means of three oval-shaped rings. The oval-shaped rings afford flexibility to the chain. In good-quality chains, the joints of links are welded so that change in length will be reduced considerably due to stretching. The ends of the chain are provided with brass handles with swivel joints so that the chain can be turned round without twisting. The outside of the handle is the zero point or the end of the chain. The length of a link is the distance between the centres of the two consecutive middle rings. The end links also include the handles. Metallic tags of different patterns called tallies are fixed at specific points of a chain, for quick and easy reading of the distance. For every five metres, there will be a tally. On tallies, the letter M will be engraved so as to distinguish a metric chain from a nonmetric chain. The length of the chain will be available in standard length of 20 or 30 m on the handle for easy identification. The details of a metric chain is shown in Fig. 2.4.



**Fig. 2.4** Details of a metric chain

### 2.7.3 Steel Band

A steel band consists of a ribbon of steel with a brass swivel handle at each end. The width of the band is 16 mm and the length may be 20 or 30 m. The graduations in it are marked in two ways:

1. The band is divided by brass studs at every 0.2 m and numbered at every one metre. The first and last links are subdivided into centimetres and millimetres.
2. The graduations are etched as metres, decimetres, centimetres on one side and 0.2 m links on the other side. The band is wound on an open steel cross or in a metal steel case.

#### Advantages

1. Measurements using steel bands are more accurate than chaining.
2. It is lighter and easier to handle.
3. The length is not altered due to usage as compared to a chain.

#### Disadvantages

1. It cannot be so easily read.
2. Frequent cleaning is essential to avoid rust formation.
3. It needs proper care while handling as it breaks easily.
4. It cannot be repaired in case if it is broken.

### 2.7.4 Principle of Chain Surveying

The principle of chain surveying is to divide the area into a number of triangles of suitable sides. A network of triangles is preferred here as triangle is the simple plane geometrical figure which can be plotted with the lengths of its sides alone. Chain surveying is the simplest kind of surveying. In this case, there is no need for measuring angles.

### 2.7.5 Suitability of Chain Surveying

1. It is suitable when the ground is fairly level and open with simple details.
2. When large scale plans are needed, this type is suitable.
3. It is suitable when the area to be surveyed is comparatively small in extent.
4. It is suitable for ordinary works as its length alters due to continued use.
5. Sagging of chain due to its heavy weight reduces the accuracy of measurements.
6. It can be read easily and repaired in the field itself.
7. It is suitable for rough usage.

### 2.7.6 Unsuitability of Chain Surveying

1. It is unsuitable for large areas crowded with many details.
2. It is unsuitable for wooded areas and undulating areas.

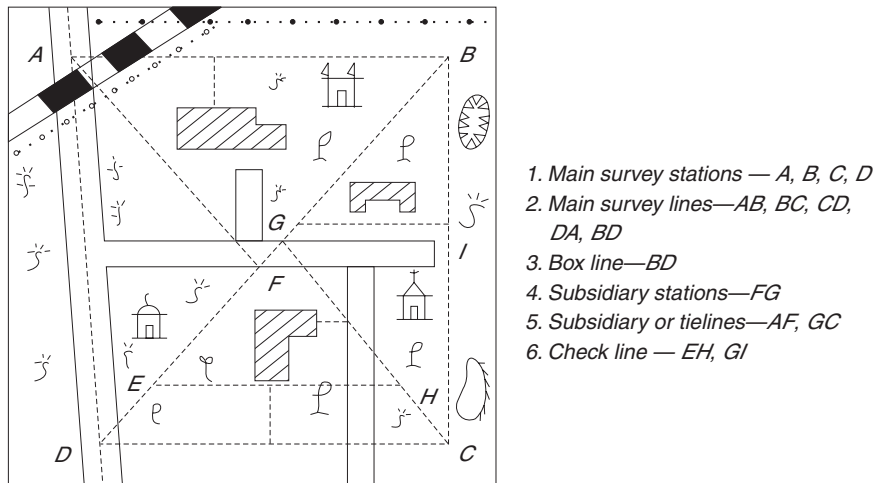
### 2.7.7 Technical Terms in Chain Surveying

These terms are explained below with reference to Fig. 2.5.

**1. Main Survey Station** It is the point where two sides of a main triangle meet.

**2. Tie Stations** These are the stations selected on the main survey lines for running auxiliary lines. These are otherwise called as subsidiary stations.

**3. Base Line** It is the longest of the main survey lines. This line is the main reference line for fixing the positions of various stations and also to fix the direction of other lines. This should be carefully measured and laid as the accuracy of entire triangulation critically depends on this measurement.

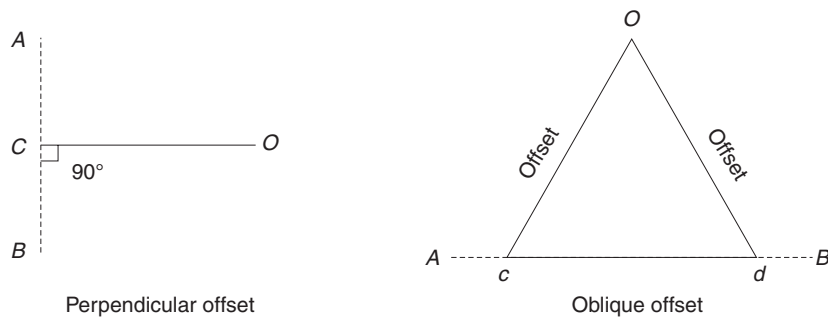


**Fig. 2.5** *Layout of a chain survey*

**4. Check Line** A check line is used in the field in order to check the accuracy of the measurements made.

**5. Tie Line** The chain line joining the tie stations and subsidiary stations is called so.

**6. Offset** While survey is carried out, important details such as boundaries, fences, buildings and towers are located with respect to main chain lines by means of lateral measurements. The two types of offsets shown in Fig. 2.6 are the perpendicular offset and the oblique offset.



**Fig. 2.6** *Offset*

### 2.7.8 Electronic Methods of Measuring Distance

In the electronic methods, distances are measured with the instruments that rely on propagation, reflection and subsequent reception of either radio or light waves.

Various instruments that are used under electronic methods

- (i) Geodimeter
- (ii) Tellurometer
- (iii) Decca navigator
- (iv) Lambda position fixing systems

Geodimeter is based on the propagation of modulated light waves. Other three instruments are based on radio waves for distance measurements. Geodimeter and Tellurometer are chiefly employed for measurement of distance on land. Decca navigator and lambda position of fixing system are used at sea.

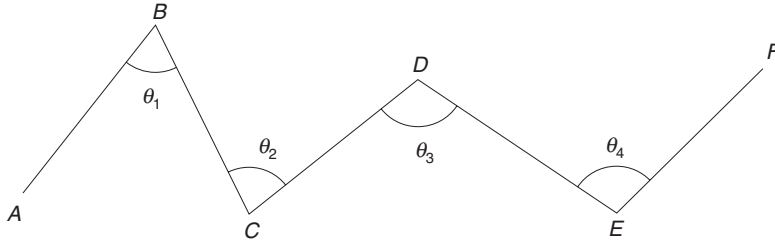
### 2.8 MEASUREMENT OF ANGLES

The instruments commonly used for measurement of angles are the compass and the theodolite. Sometimes, a box sextant is also used.

### 2.8.1 Method of Measurement of Angles

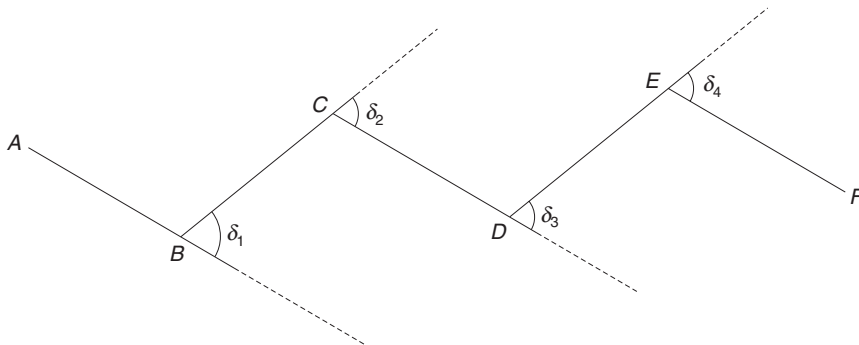
The horizontal angles may be measured in two ways:

1. Included angles, as indicated in Fig. 2.7 (a).



**Fig. 2.7 (a)** *Included angles*

2. Deflection angles between successive lines, as shown in Fig. 2.7 (b).



**Fig. 2.7 (b)** *Deflection angles*

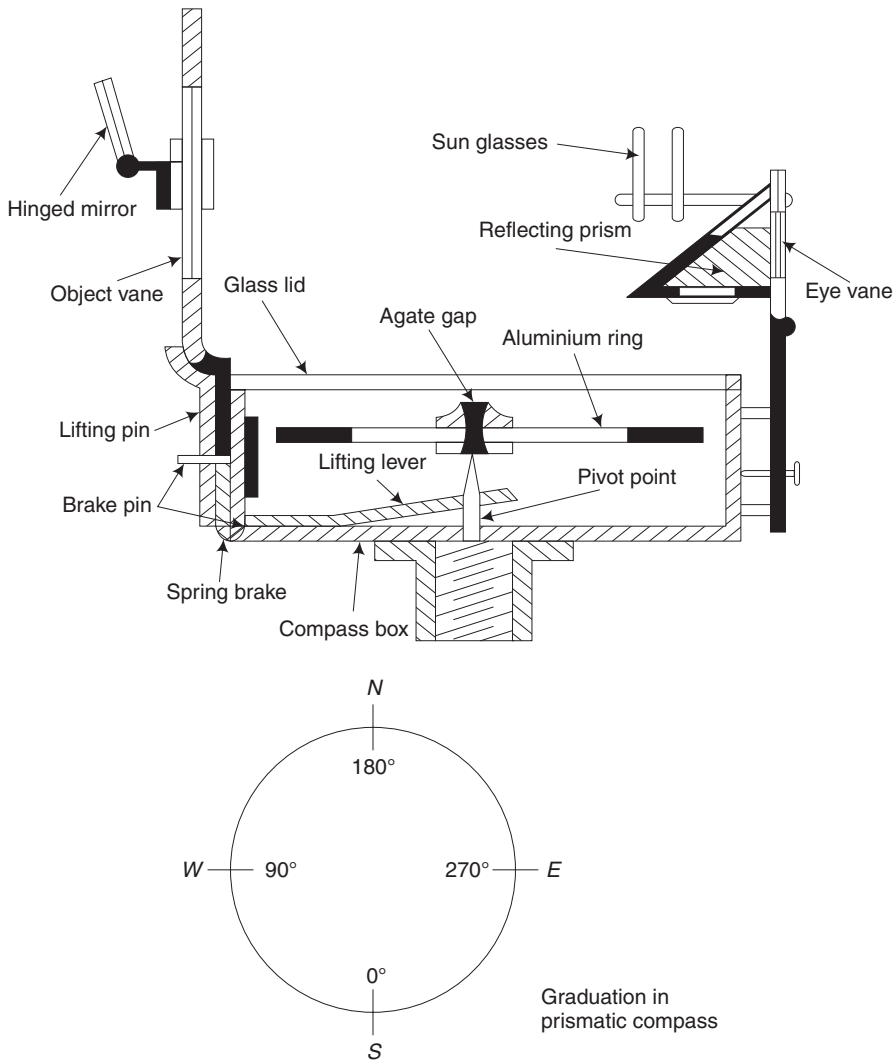
### 2.8.2 Compass

[May, June 2012, 2013, 2014]

This instrument essentially consists of a freely suspended magnetic needle on a pivot, which can move over a graduated scale. In addition to the above, it has an object vane and an eye vane which will be useful to get the line of sight. This instrument will be supported by a tripod stand while taking observations.

The two types of compass are the prismatic compass and the surveyor's compass.

**1. Prismatic Compass** It is the most suitable type of rough surveys where speed is very important rather than accuracy. It is commonly used for the preliminary survey for a road, railway, military purposes, a rough traverse, etc. The result from compass observations may be unrealistic in places where there is more local attraction due to magnetic rock or iron ore deposits. Figure 2.8 shows the different parts of a prismatic compass.

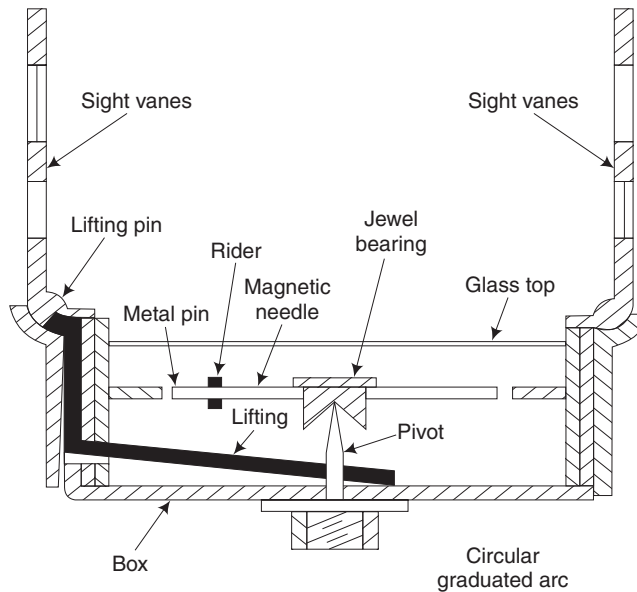


**Fig. 2.8** *Prismatic compass*

**2. Surveyor's Compass** This type is not often used now for land surveying. In general, it is similar to a prismatic compass except that it has another plain sight having a narrow vertical slit in place of the prism as detailed in Fig. 2.9.

### 2.8.3 Bearing

Bearing is the horizontal angle between the reference meridian and the survey line. It is measured in the clockwise direction. Bearings are classified into different types and each of the type is described in this section.



**Fig. 2.9** Surveyor's compass

**1. True Bearing** True bearing of a line is the angle which a line makes with the true north or geographical north, measured always in the clockwise direction. The range of measurement is from  $0^\circ$ – $360^\circ$ .

**2. Magnetic Bearing** It is the angle which a line makes with the magnetic north measured always in the clockwise direction. The measuring range is from  $0^\circ$ – $360^\circ$ .

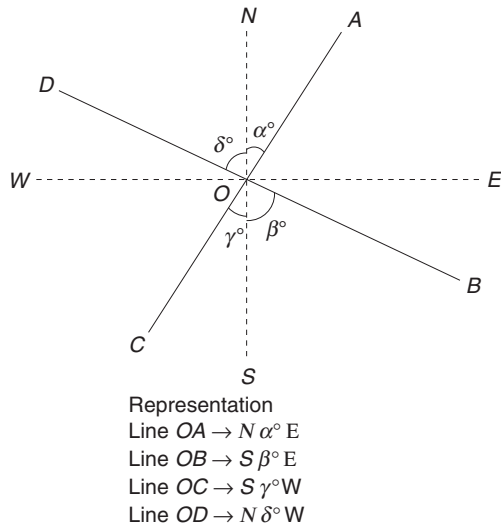
**3. Whole Circle Bearing (WCB)** Since the range of  $0^\circ$  to  $360^\circ$  completes a circle, any angle measured in between  $0^\circ$  to  $360^\circ$  directly is called a whole circle bearing. The magnetic and true bearing are just whole circle bearings. [Nov, Dec 2009]

**4. Reduced Bearing (RB)** This is based on quadrantal system wherein any angle is measured with respect to the north–south line, towards east or west as shown in Fig. 2.10. [Nov, Dec 2009]

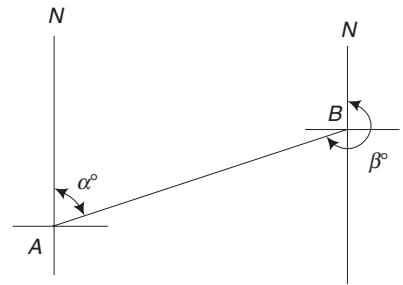
**5. Fore Bearing (FB)** The angle measured from a survey station to the other station, in the direction in which survey is conducted, is called the fore bearing. In Fig. 2.11, the bearing of line *A* to *B* is the fore bearing.

**6. Back Bearing (BB)** It is the bearing taken from the next station to its preceding station from which the fore bearing was taken. Referring to Fig. 2.11, the bearing taken from station *B* towards station *A* is the back bearing of the line *AB*. In WCB system,  $BB = FB \pm 180^\circ$  using +ve sign if the FB is less than  $180^\circ$  and –ve sign if the FB is greater than  $180^\circ$ . In RB system, to convert FB into BB or vice versa, N is replaced by S, S by N, E by W and W by E without changing the numerical value of its bearing.





**Fig. 2.10** *Reduced bearing (or) quadrantal bearing*



NAB =  $\alpha^\circ$  = fore bearing  
 NBA =  $\beta^\circ$  = back bearing  
 $\therefore$  Fore bearing – back bearing =  $180^\circ$

**Fig. 2.11** *Fore and back bearing*

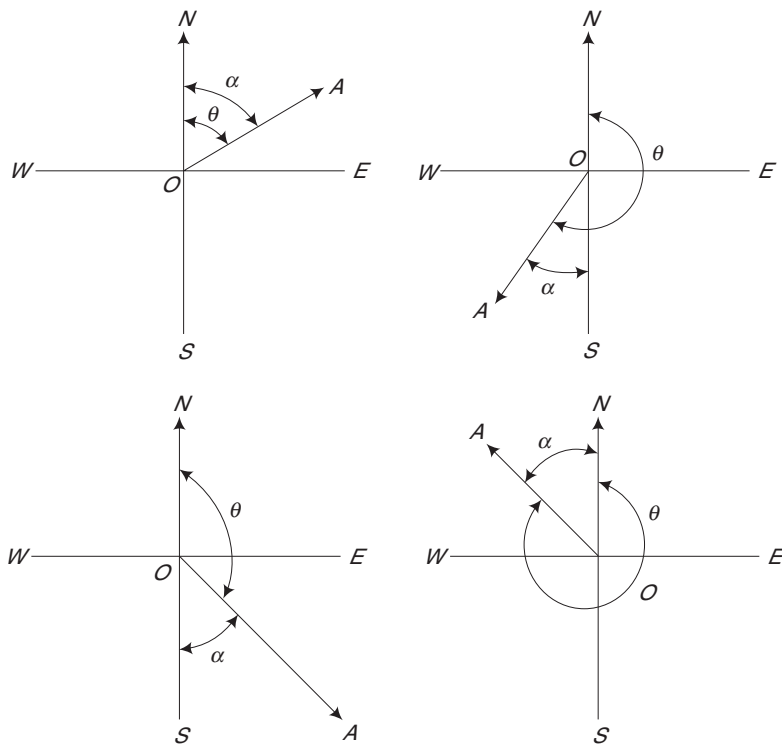
**Table 2.1** *Comparison between prismatic compass and surveyor's compass*

Prismatic compass	Surveyor's compass
1. In the prismatic compass, the magnetic needle and the graduated dial are attached together while the prism and the box rotate.	In the surveyor's compass, the magnetic needle remains freely suspended and stationary while the dial is attached to the box.
2. The graduations are provided in the clockwise direction.	In this case, the graduations are marked from $0^\circ$ to $90^\circ$ in all the four quadrants.
3. Readings are observed by looking through the prism eye-piece from the south end of the compass.	Readings are taken by directly looking on the dial immediately below the north end of the needle.
4. The zero of the reading is marked on the south end of the instrument.	Here, it is marked on the north and south end.
5. A mirror is attached to the object vane for sighting objects at higher elevations or depression.	No such mirror is provided in the object vane.
6. The position of east and west are in their correct positions.	The position of east and west are interchanged.
7. By using this, one can obtain directly the whole circle bearings.	This is based on quadrantal system having $0^\circ$ at north and $90^\circ$ at east and west ends. With this, it is possible to read only the reduced bearings.
8. The prismatic compass may be held in hand while taking observations.	The surveyor's compass needs a light tripod or a single pointed rod to support it.

Table 2.2 gives the rules to convert WCB to RB and the conversion is illustrated in Fig. 2.12.

**Table 2.2** Conversion of WCB to RB

Case	WCB between	Rule for RB	Quadrant
I	$0^\circ$ and $90^\circ$	WEB	NE
II	$90^\circ$ and $180^\circ$	$180^\circ - \text{WCB}$	SE
III	$180^\circ$ and $270^\circ$	$\text{WCB} - 180^\circ$	SW
IV	$270^\circ$ and $360^\circ$	$360^\circ - \text{WCB}$	NW



**Fig. 2.12** Conversion of WCB to RB

When a line lies exactly along North, South, East or West, if

WCB of a line =  $0^\circ$ , then, RB is N

WCB of a line =  $90^\circ$ , then, RB is E  $90^\circ$

WCB of a line =  $180^\circ$ , then, RB is S

WCB of a line =  $270^\circ$ , then, RB is W  $90^\circ$

Table 2.3 presents the rules to convert RB to WCB

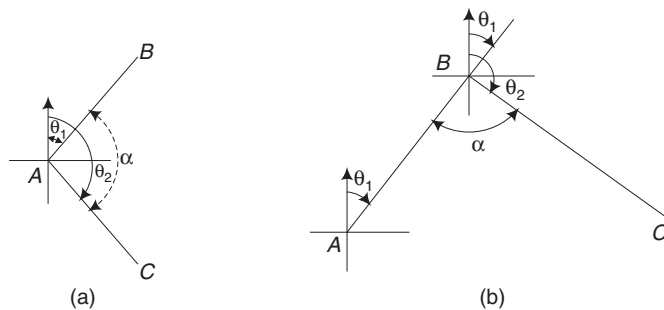
**Table 2.3** Conversion of RB to WCB

Case	RB Quadrant	Rule for WCB	WCB between
I	NE	RB	0° and 90°
II	SE	180° - RB	90° and 180°
III	SW	180° + RB	180° and 270°
IV	NW	360° - RB	270° and 360°

### 2.8.4 Calculation of Angles from Bearings

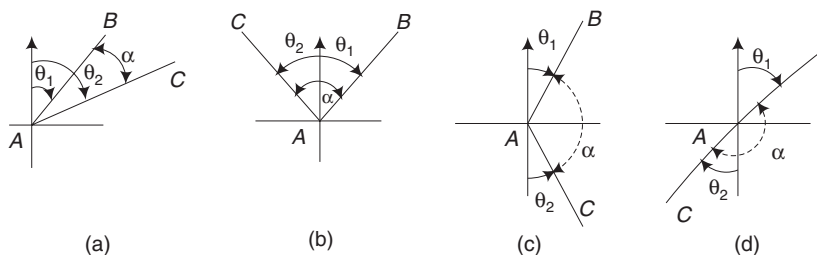
Knowing the bearing of two lines, the angle between the two can very easily be calculated with the help of a diagram.

Ref., to Fig. 2.13(a), the included angle  $\alpha$  between the lines AC and AB =  $\theta_2 - \theta_1 =$  FB of one line - FB of the other line, both bearings being measured from a common point A. Reference to Fig. 2.13(b), the angle  $\alpha = (180^\circ + \theta_1) - \theta_2 =$  BB of previous line - FB of next line.



**Fig. 2.13**

Let us consider the quadrantal bearing, referring to Fig. 2.14(a) in which both the bearings have been measured to the same side of common meridian, the included angle  $\alpha = \theta_2 - \theta_1$ . In Fig. 2.14(b), both the bearings have been measured to the opposite sides of the common meridian, and included angle  $\alpha = \theta_1 + \theta_2$ . In Fig. 2.14(c) both the bearings have been measured to the same side of different meridians and the included angle  $\alpha = 180^\circ - (\theta_2 + \theta_1)$ . In Fig. (d), both the bearings have been measured to the opposite sides of different meridians, and angle  $\alpha = 180^\circ - (\theta_1 - \theta_2)$ .



**Fig. 2.14**

Thus Fig 2.14 main advantage of the quadrantal bearings is that they never exceed  $90^\circ$  and the values of their trigonometrical functions can easily be extracted from the ordinary tables. They, however, possess the following disadvantages:

- (i) It is necessary to put the appropriate cardinal points without which the bearings will have no significance.
- (ii) The alternate clockwise and anti clockwise direction of increase of angle in the different quadrants is sometimes inconvenient and may very easily lead to mistakes being made.
- (iii) The noting of the cardinal points may prove to be an extra unnecessary trouble.

The following are the advantages of this system:

- (i) It is easy to calculate the included angle between two lines with the help of this system of bearings.
- (ii) The convention of reckoning the bearing clockwise from the magnetic north is so simple that it is not necessary to remember whether the bearings are observed with reference to the north meridian or south meridian.
- (iii) The plotting of traverse becomes easy because the bearings are to be measured only in the clockwise direction.
- (iv) There is no botheration of putting the cardinal points.

The only drawback of this system is that when the bearings are to be used for computation and where the values of the trigonometrical functions are required, they are to be reduced to their equivalent values.

### 2.8.5 Local Attraction

If external magnetic influences are present in the place of observation using a compass, The needle will be seriously deflected from its normal position. Such disturbance due to the surrounding magnetic field is called local attraction.

The readings observed will be affected due to the presence of magnetic rocks or iron-ore deposits, steel structures, railways, iron lamp posts, electrical steel towers, etc. The actual bearing may be affected if we carelessly keep a bunch of iron keys, knife, iron buttons, steel-framed spectacles, the chain itself, arrows, etc. near the instrument. To detect its presence, one has to find the fore and back bearing of a line and obtain the difference between them. If the difference is not exactly equal to  $180^\circ$  then it indicates the presence of local attraction, provided there are no instrumental and observational errors.

### 2.8.6 Traversing with Compass and Chain

In compass traversing, the instrument is set at each station successively and the fore and back bearings of each line are noted in the field note book. The errors in this survey tend to compensate as each bearing is observed independently. Distances between the successive stations are measured using the chain. The offset points are located either by chaining or by angular measurements with compass.

## 2.9 LEVELLING

[Nov, Dec 2010]

### 2.9.1 Definition

It is defined as the art of determining the relative heights of points on the earth's surface. This technique of surveying deals with measurements in vertical planes.

### 2.9.2 Objectives

Levelling provides an accurate network of heights, covering the entire area of the project. For the execution of many engineering projects levelling becomes very essential. For instance, the construction of railways, highways, canals, dams, water supply, sanitary lines, etc. is done through the determination of elevations of different points along the alignment (alignment involves the fixing of the centre line of railway or highway as the case may be). Greater the accuracy in the observations, the greater will be the saving in expenditure during project execution. A good network of levels provides an excellent idea of the existing terrain for the engineer, who can then plan and design his project keeping in view the economy and safety.

### 2.9.3 Technical Terms used in Levelling

**Level surface** The surface which is normal to the direction of gravity at all points is called a level surface. Every point on the level surface will be equidistant from the centre of the earth. For example, the surface of a still lake forms a level surface.

**Horizontal plane** The plane tangential to the level surface at any point is known as a horizontal plane.

**Vertical plane** The plane which contains vertical line at a place is called a vertical plane. The vertical line at any point will be perpendicular to the level surface at that point.

**Datum surface** This is an arbitrary surface with reference to which the heights (elevations) of points are measured and compared.

**Reduced level (RL)** Reduced level of a point is its height above or below the datum.

**Back sight (BS)** It is the first staff reading taken after setting up the instrument in any position. This will always be a reading on a point of known height.

**Fore sight (FS)** This is the last staff reading taken on a point before shifting the instrument. This will always be a point whose height has to be determined.

**Intermediate sight (IS)** Intermediate sight refers to any staff reading taken on a point of unknown elevation after the back sight and before the fore sight. This is necessary if it is needed to take more than two readings from the same position of the instrument.

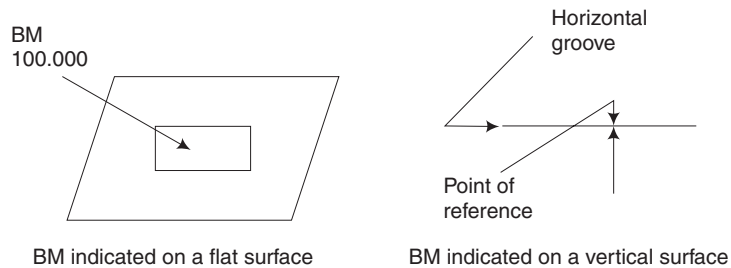
**Change point (CP)** A change point indicates the shifting of the instrument. Both the back sight and the fore sight are taken on a change point.

**Benchmark (BM)** A benchmark is a fixed point of reference of known elevation. The reduced level of the benchmark is used to determine the reduced levels of other points.

Benchmarks are classified into the following types:

- (a) Great Trigonometrical Survey benchmarks (GTS bench marks)
- (b) Permanent benchmarks
- (c) Arbitrary benchmarks
- (d) Temporary benchmarks

GTS bench marks are those established by the Survey of India Department. The notation of a Benchmark is shown in Fig. 2.15. In small levelling works, the reduced level of a well defined reference point is arbitrarily assumed and is called as an arbitrary benchmark. Temporary benchmarks are the reference points which are established when there is a break in the work.



**Fig. 2.15** *Notation of benchmark*

#### 2.9.4 Principle of Levelling

[Apr, May 2015, Regulation 2008]

Figure 2.16 illustrates the operations of levelling and Fig. 2.17 explains the principle of levelling. The principle of levelling lies in furnishing a horizontal line of sight and finding the vertical distances of the points above or below the line of sight. The line of sight is provided with a level. A graduated levelling staff is used to measure the height of the line of sight.

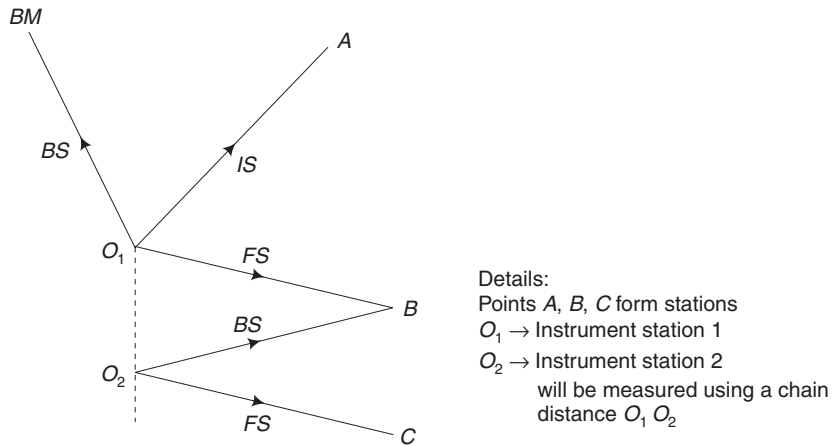
Let  $O$  represent the centre of the earth.  $A$  and  $A'$  are the points whose difference in elevation is required.  $C$  is the position of the instrument (level). The line  $CO$  is the direction of plumb line.  $BB'$  denotes the line of sight which is perpendicular to  $CO$ .  $AB$  and  $A'B'$  are the readings on a staff vertically held at points  $A$  and  $A'$  respectively.

$$OA + AB = OA'' + A''A' + A'B'$$

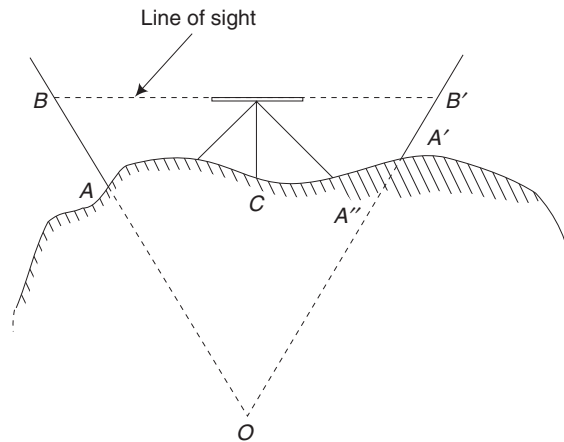
or

$$AB - A'B' - AA' = dh$$

where  $dh$  is the difference in elevation between the points  $A$  and  $A'$ .



**Fig. 2.16** Explanatory figure of a levelling operation



**Fig. 2.17** Principle of levelling

In order to nullify the effect of curvature of earth's surface, the distances of both the staff positions from the instrument station  $C$  are kept equal.

### 2.9.5 Level

The instrument which is used for levelling is known as a level. It essentially consists of the following accessories:

1. A telescope to provide the line of sight.
2. A level tube to make the line of sight horizontal.

3. A levelling head to bring the bubble of the tube level at the centre of its run.
4. The tripod to support the above parts of the level.

In order to take readings of elevations, levelling staffs are used.

### 2.9.6 Instruments for Levelling

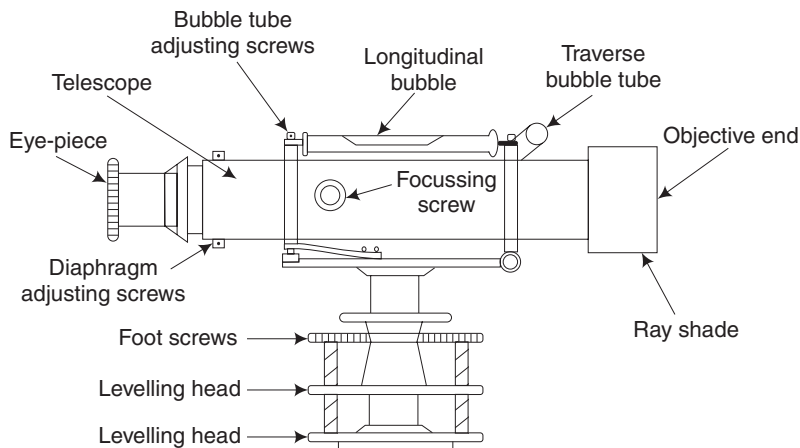
[Nov, Dec 2009]

Instruments needed for levelling are the Dumpy levels and the levelling staff.

**1. Dumpy Levels** Figure 2.18 shows the different parts of a Dumpy level which was designed by Gravatt. This is also called the solid Dumpy level. In this, the telescope is rigidly fixed to the base so that the telescope can neither be rotated about its longitudinal axis nor it can be removed from the supports. This instrument consists of a long bubble tube attached to the fixed telescope. Dumpy literally means short and thick. This is more stable than the other types.

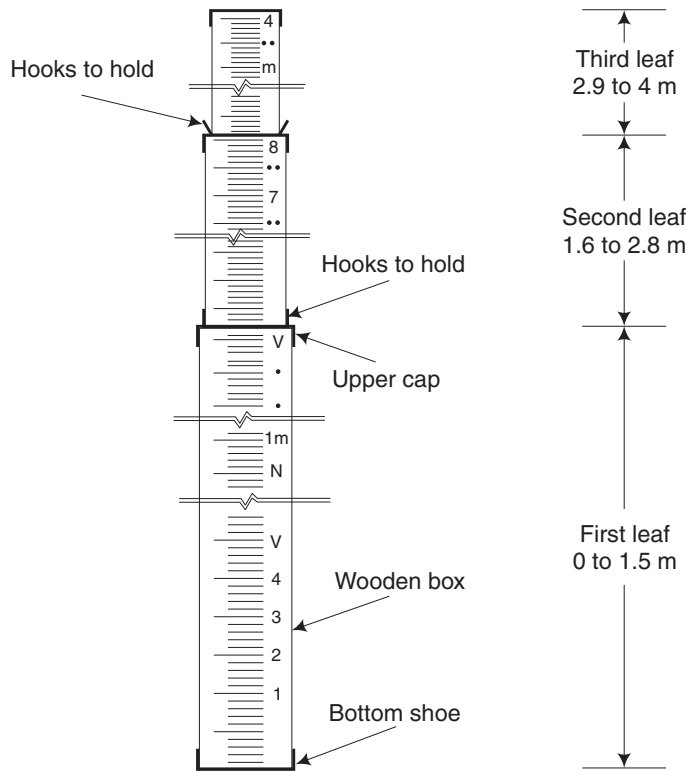
**2. Levelling Staff** A levelling staff is a straight rectangular wooden rod graduated in metres and smaller divisions. The bottom-most reading is zero and the reading given by the line of sight on the staff is the height of the point on which the staff is held.

The telescopic levelling staff shown in Fig. 2.19 is made of three pieces, the topmost and the central pieces are 1.25 m long, the bottom-most being 1.5 m long. The central and the bottom rods are hollow and the top one is solid. The top staff slides into the central piece telescopically so that the staff is compact when not used. The markings are same as that of the folding staff except the metre numerals are replaced by the alphabet *M* and the graduations marked erect so that when viewed through the telescope, it is inverted.



**Fig. 2.18** Dumpy level





**Fig. 2.19** 4 m telescopic levelling staff

### 2.9.7 Classification of Levelling

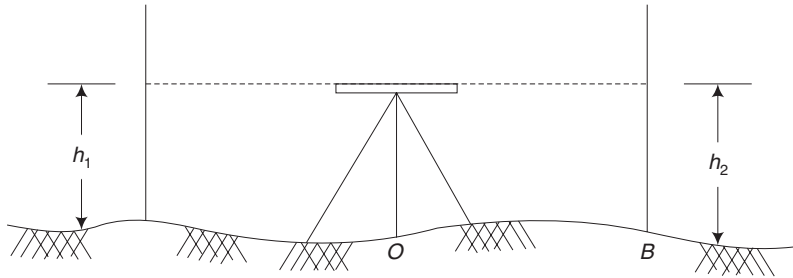
[Nov, Dec 2009; May, June 2011]

Levelling may be classified as simple levelling and differential levelling.

**1. Simple Levelling** Figure 2.20 illustrates simple levelling. Simple leveling is the easiest way adopted to find the difference in level between any two points. Let  $A$  and  $B$  are the two points and  $O$  be the station point placed approximately midway between  $A$  and  $B$ . Station  $O$  need not lie on the line joining  $A$  and  $B$ . The reading of the staff at  $A$  is first taken. Let this be  $h_1$ . Then, the reading of the staff  $h_2$  at  $B$  is noted after adjusting the bubble to be at the centre. The difference between the two readings, i.e,  $h_1 - h_2$  gives the difference in level between  $A$  and  $B$ .

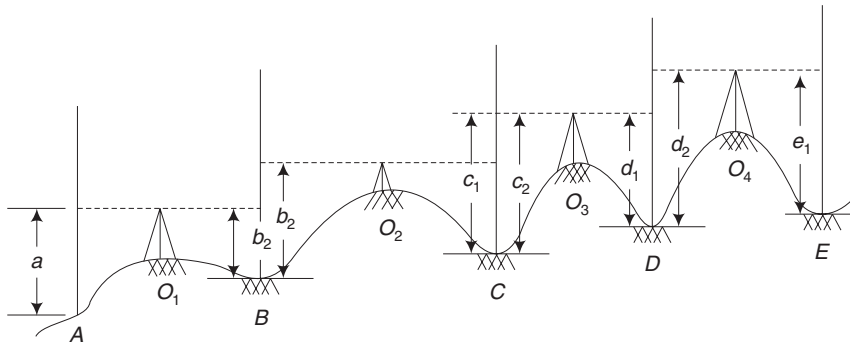
If reduced level of  $A$  is 100, then, RL of  $B$  can be found as follows:

$$\begin{aligned} \text{Height of instrument at } O &= 100 + h_1 \\ \text{RL of } B &= 100 + h_1 - h_2 \end{aligned}$$



**Fig. 2.20** Simple levelling

**2. Differential Levelling** Differential levelling is illustrated in Fig. 2.21. If it is necessary to find the difference in elevation between two points which are too far apart or if there are any obstacles between them or if the difference in elevation is high then differential levelling is adopted. This is a simple levelling adopted in successive stages. Hence, it is also known as compound or continuous levelling.



**Fig. 2.21** Differential levelling

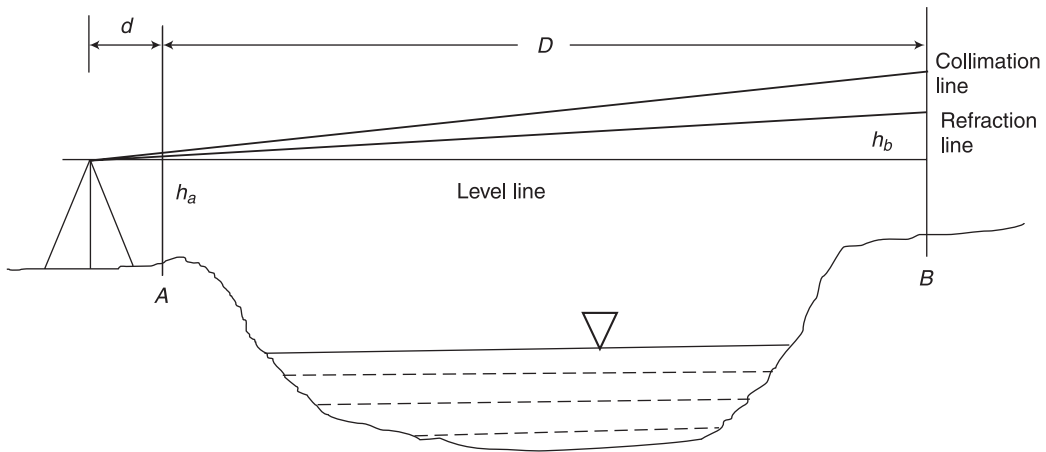
[May, June 2011]

Let  $A$  and  $E$  be two points whose difference in elevation is necessary. The staff reading at  $A$  is noted as  $a$  from station point  $O_1$ . After adjusting the bubble, the staff reading at a firm point  $B$  is noted from  $O_1$  as  $b_1$ . The staff reading  $a$  is the back sight and  $b$ , is the foresight.  $B$  is selected such that  $AO_1$  is approximately equal to  $O_1B$ . Now, the instrument is shifted to  $O_2$  and the staff reading at  $B$ , from  $O_2$  is taken and noted as  $b_2$ . Another firm point  $C$  is selected and the procedure is repeated till the point  $E$  is reached. The difference in level between  $A$  and  $B$  is  $(a - b_1)$ . The difference in level between  $B$  and  $C$  is  $(b_2 - c_1)$  and so on. The difference in level between  $A$  and  $E$  are the algebraic sum of these differences.

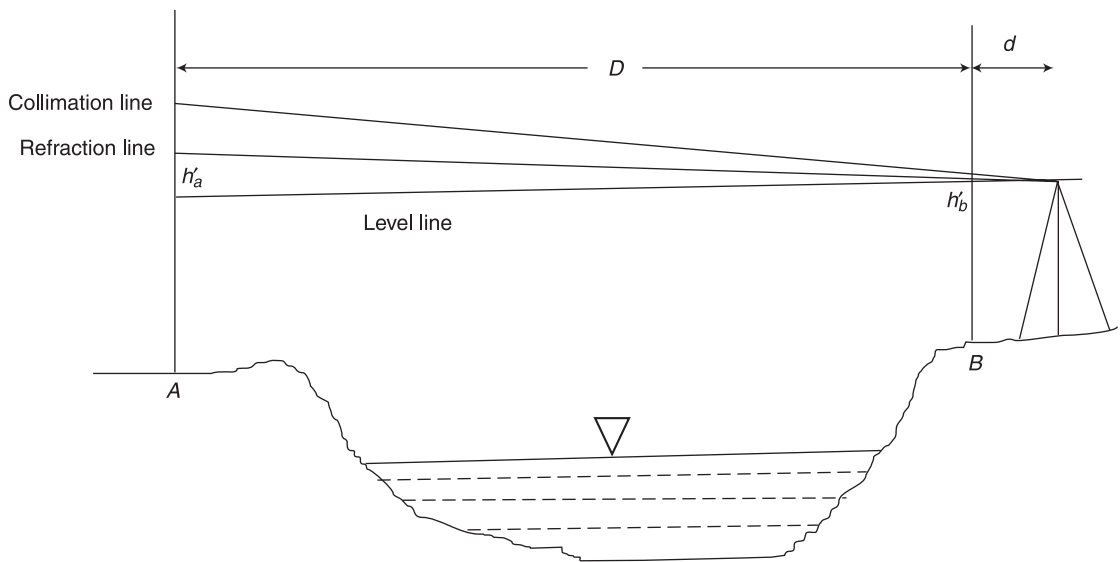
**3. Reciprocal Levelling** This is a method of finding the difference in elevation between two points by making reciprocal observations when the site conditions do not allow to set up the level between the two stations.

On occasions, we come across a need to run a line of levels across a wide gap like a river or a deep valley or ravine. The site conditions do not allow to place the level anywhere so that the Foresight and the Back sight distances are even approximately equal. The site conditions also do not permit to set up the instrument exactly midway between stations on either side of the gap. In view of the large sight lengths the errors due to curvature and refraction and non adjustment of the instrument become important.

In such situation reciprocal levelling can be performed by which correct difference of levels can be determined taking into account the error due to curvature and refraction as well as collimation error.



**Fig. 2.22**



**Fig. 2.23**

Let  $A$  and  $B$  be two stations on opposite banks of a river or stream. Let  $A$  be at a higher level than  $B$ . Let  $D$  be the horizontal distance between  $A$  and  $B$ . Suppose the line of collimation of the instrument is elevated. Refer Fig. 2.23.

The instrument is set up on the left side of  $A$  in line with  $AB$  at a distance  $d$  from  $A$ . Let  $h_a$  and  $h_b$  be the staff reading obtained over  $A$  and  $B$  respectively. Refer Fig. 2.22.

$$\text{Correct staff reading at } A = h_a - K_1d - K_2d^2$$

$$\text{Correct staff reading at } B = h_b - K_1(D + d) - K_2(D + d)^2$$

where  $K_1$  = Coefficient to correct for collimation error

$K_2$  = Coefficient to correct for curvature and refraction

$$\text{True Difference of Level} = h = [h_b - K_1(D + d) - K_2(D + d)^2] - [h_a - K_1d - K_2d^2]$$

Now the instrument is set up on the other bank on the right side of  $B$  in line with  $BA$  at a distance  $d$  from  $B$ . Refer Fig. 2.23.

$$\text{Correct staff reading at } A = h'_a - K_1(D + d) - K_2(D + d)^2$$

$$\text{Correct staff reading at } B = h'_b - K_1d - K_2d^2$$

$$\text{True Difference of Level} = h = [h'_b - K_1d - K_2d^2] - [h'_a - K_1(D + d) - K_2(D + d)^2]$$

Adding above equations of true differences of level, we get

$$2h = [h_b - h_a] + [h'_b - h'_a]$$

$$\text{True difference of level} = h = \{[h_b - h_a] + [h'_b - h'_a]\} / 2$$

### 2.9.8 Reduction of Levels

There are two methods for calculating the reduced levels of points, the height of collimation or height of instrument method and the rise and fall method. In this section, these methods are discussed.

**1. The Height of Collimation or Height of Instrument Method** In this method, the height of instrument (HI) is calculated for each setting by adding the back sight (BS) to the elevation of BM. The reduced level of the first station or of the intermediate station can be obtained by subtracting the foresight at the first station or the intermediate sight at the intermediate station.

For the second setting HI is calculated by adding the back sight taken on the second point to its reduced level. The reduced level of the last point is obtained by subtracting the foresight of the last point from the HI at the last setting. Arithmetic check can be done in the following manner.

$$\Sigma \text{BS} - \Sigma \text{FS} = \text{Last RL} - \text{First RL}$$

This method is simple, easy and rapid.

**Table 2.4** Comparison of Height of Collimation Method with the Rise and Fall Method

<i>Height of collimation method</i>	<i>Rise and fall method</i>
1. It is more rapid and saves time and labour.	It is laborious as the staffreading of each station is compared to get a rise or fall.
2. It is adopted for reduction of levels for longitudinal or cross sectional levelling works.	This is adopted for determining the difference in levels of two points where precision is required.
3. There is no check on the RL of intermediate stations.	There is a complete check on the RLs of intermediate stations.
4. There are only two arithmetic checks, i.e. $\Sigma BS - \Sigma FS = \text{Last RL} - \text{First RL}$	There are three arithmetic checks, i.e. $\Sigma BS - \Sigma FS = \text{Last RL} - \text{First RL} = \Sigma \text{Rise} - \Sigma \text{Fall}$
5. Errors in any of the intermediate sights are not noticed.	Errors in the intermediate sights are noticed as these are used for finding out the rises and falls.

**2. Rise and Fall Method** In this method, the difference of level between two consecutive points for each setting of the instrument is obtained by comparing their staff readings. A rise is indicated if the back sight reading is greater than the foresight and a fall is shown if it is less than the foresight reading. The rise and fall worked out for all the points give the level difference of each point with respect to the preceding one. If the RL of the back staff point is known, the RL of the following point can be obtained by subtracting its fall from the RL of the preceding point or by adding its rise to the RL of the preceding point. Arithmetic check is done as explained below:

$$\Sigma BS - \Sigma FS = \Sigma \text{Rise} - \Sigma \text{Fall} = \text{Last RL} - \text{First RL} \quad [\text{Apr, May 2014}]$$

## 2.10 DETERMINATION OF AREAS

The primary object of land surveying is to determine the area of the tract surveyed. Area is defined as the area of a tract of land as projected upon a horizontal plane and not the actual area of the surface of the land. The units of area in metric system commonly used are square metres or hectares.

### 2.10.1 Computation of Areas by Direct Field Measurements [May, June 2011]

The area to be measured may not always be a regular polygon. In this case, the region is divided into a regular polygon and the portion between the irregular boundary and regular polygon. The area can be found by dividing the regular polygon into triangles.

**1. By Dividing the Area into Number of Triangles** In this method illustrated in Fig. 2.24, the area is divided into a number of triangles and the area of each triangle is calculated by measuring their sides and included angles. Then, the total area of the land will be equal to the sum of areas of individual triangles.

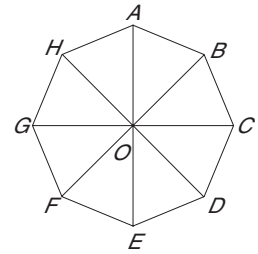
If two sides and one included angle of a triangle is known then area

$$= \frac{1}{2} ab \sin \theta$$

When the lengths of the three sides of a triangle are measured, then,

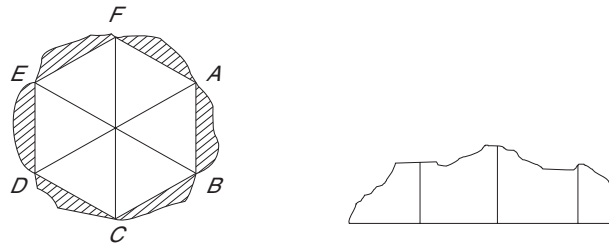
$$\text{Area} = \sqrt{S(S-a)(S-b)(S-c)}$$

where  $S = \frac{1}{2}(a+b+c)$  and  $a, b, c$  are sides of the triangle.



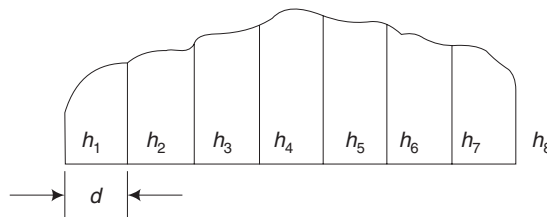
**Fig. 2.24**

**2. Areas between the survey lines and boundaries** In this method illustrated in Fig. 2.25, a number of offsets are measured from the survey line to the boundary one at regular intervals. Then, the area between survey line and boundary line can be measured by the following rules.



**Fig. 2.25**

**(a) Trapezoidal rule** This is based on the assumption that the figures are trapezoids. The base line  $AB$  is divided into equal parts. The ordinates are measured and their lengths are scaled off. This procedure is explained in Fig. 2.26. [May, June 2011]



**Fig. 2.26**

$h_1, h_2, \dots, h$  – length of ordinates at equal intervals  
 $n$  – number of divisions

$L$  – length of the base line  
 $d$  – distance between adjacent ordinates

**Note:** If  $h_1$  or  $h_n$  is equal to zero, that is also included in the formula.

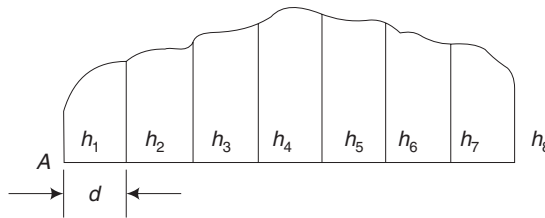
$$\begin{aligned} \text{Total area, } A &= \frac{d}{2} (h_1 + 2h_2 + 2h_3 + \dots + 2h_{n-1} + h_n) \\ &= \frac{d}{2} [\text{first ordinate} + 2 (\text{sum of intermediate ordinates}) + \text{last ordinate}] \end{aligned}$$

**(b) Simpson's rule** As illustrated in Fig. 2.27, in this rule, the terms and procedures are same as that of the above rule. But total area is given by:

$$A = \frac{d}{3} [h_1 + h_n + 2 (h_3 + h_5 + h_7 + \dots + h_{n-2}) + 4 (h_2 + h_4 + \dots + h_{n-1})]$$

i.e., 
$$A = \frac{d}{3} [\text{First ordinate} + \text{Last ordinate} + 2 (\text{sum of odd ordinates}) + 4 (\text{sum of remaining even ordinates})]$$

[May, June 2011]



**Fig. 2.27**

**Note:**

- (i) This rule is applicable only if the number of ordinates is odd. If the number of ordinates is even, the area of the last trapezoid is calculated separately and added to the result.

From Fig. 2.27,

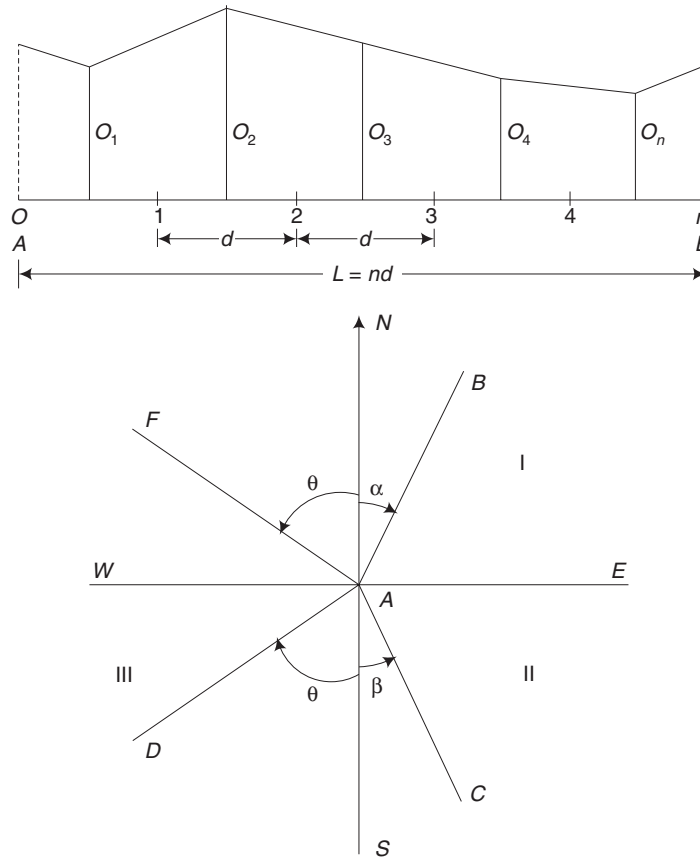
Number of ordinates = 8.

The area for first seven ordinates can be obtained by applying Simpson's rule,

$$A_1 = \frac{d}{3} [h_1 + 2(h_3 + h_5) + 4(h_2 + h_4 + h_6) + h_7]$$

$$A_2 = \frac{1}{2} (h_7 + h_8) \times d$$

Then, total area  $A = A_1 + A_2$ .



**Fig. 2.28**

(ii) If  $h_1$  or  $h_n$  is zero that is also included in the rule.

The results obtained using the Simpson's rule are more accurate than those obtained by the Trapezoidal rule.

#### **Comparison b/w Trapezoidal and Simpson's rule**

The results obtained by the use of Simpson's rule are more accurate in all cases. The results obtained by using 'Simpson's rule are greater or smaller than those obtained by using the trapezoidal rule according as the curve of the boundary is concave or convex towards the base line. In dealing with irregularly shaped figures, the degree of precision of either method can be increased by increasing the number of ordinates.

#### **Mid-ordinate rule**

The method is used with the assumption that the boundaries between the extremities of the ordinates (or offsets) are straight line. The base line is divided into a number of divisions and the ordinates are measured at the mid-points of each division, as illustrated in Fig. 2.28.



The average ordinate rule will not give correct results if the range of values of the ordinates is large. The trapezoidal rule and Simpson's rule are the most commonly used rules. Simpson's rule is considered generally more accurate, as the assumption of a curved boundary is more realistic compared to the assumption of a straight-line boundary between ordinates made in the trapezoidal rule. The method of coordinates and the trapezoidal rule give the same results, as both are based on the same assumption. If the boundary is concave towards the survey line, the Trapezoidal rule will calculate less area than the Simpson's rule, while if the boundary is convex towards the survey line, Simpson's rule will calculate a lower value.

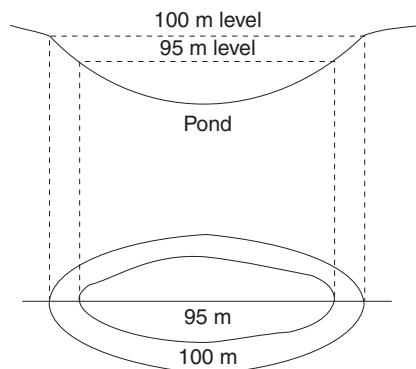
## 2.11 CONTOURING

An imaginary line, on the ground, joining the points of equal elevation above the assumed datum is called a contour. Survey work, including office work in the preparation of a contour plan is known as contouring.

The vertical distance between any two consecutive contours is called *contour interval*.

The least horizontal distance between two consecutive contours is called *horizontal equivalent*.

To get a clear concept of contouring, let us consider the case of conducting the survey work on the boundary of still water in a pond. If the level of water surface is 100 m, then the periphery of water represents a contour of 100 m. Now, if the water level is lowered by 5 m, then the new boundary represents a contour of 95 m as shown in Fig. 2.29.



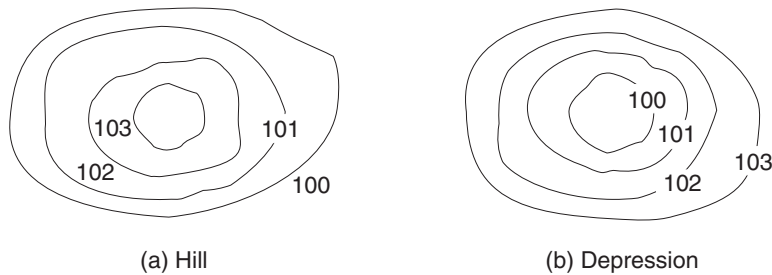
**Fig. 2.29** *Contour in still water*

### 2.11.1 Characteristics of Contours

The characteristics of contour given below are useful in plotting and for interpreting a contour map correctly.

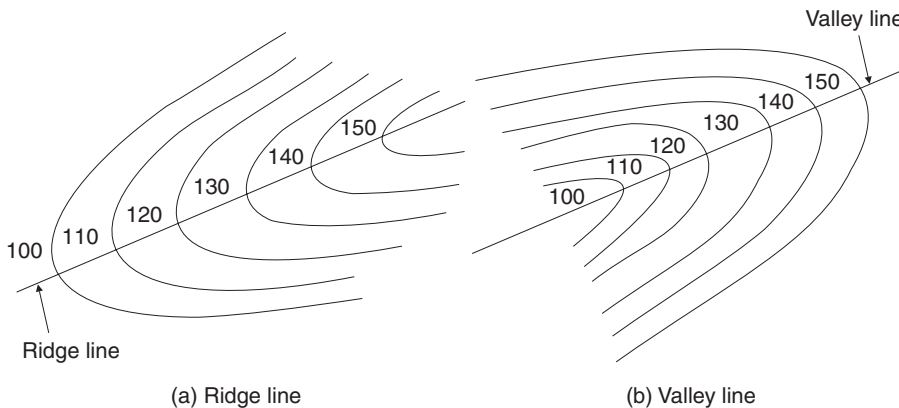
1. Contour which is equally spaced represents a uniform slope whereas one which is closely spaced represents a steep slope.

2. A series of straight, parallel, equally spaced contours represents an inclined plane surface.
3. Contour at any point is perpendicular to the line of the steepest slope at that point.
4. A series of closed contours with higher values on the inside, represents a hill and lower value on the inside indicates a pond or depression without an outlet as shown in Fig. 2.30.



**Fig. 2.30** Contour for a hill and a depression

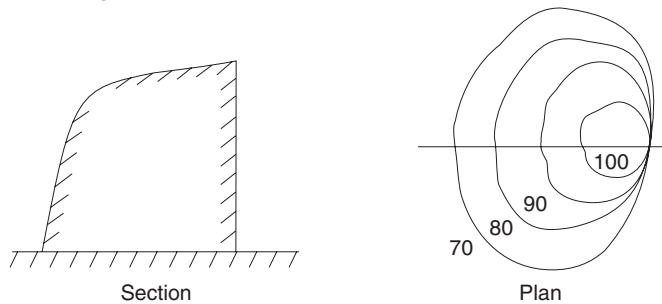
5. Contour lines cross a ridge line at right angles, curving round it with the concave side towards higher ground. Whereas for valley line the convex side is towards the higher ground as shown in Fig. 2.31.



**Fig. 2.31** Contour for ridge and valley

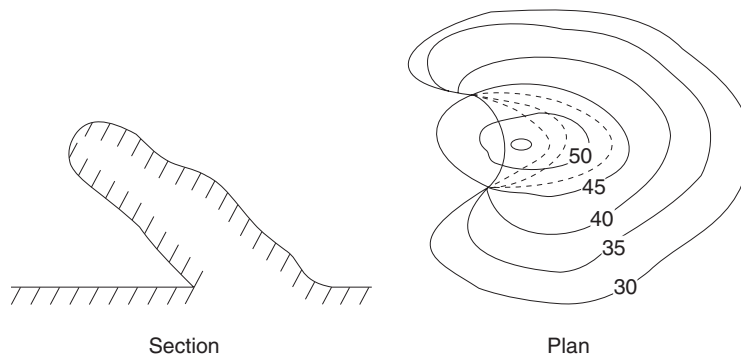
6. The same contour must appear on both sides of a ridge or a valley.
7. The contour cannot simply end anywhere, it must close on itself, though not necessarily within the limits of the map.

8. Contour lines of different elevations do not unite, except in the case of a vertical cliff as shown in Fig. 2.32.



**Fig. 2.32** Contour for a vertical cliff

9. Contour of different elevations can cross each other only in case of an overhanging cliff as shown in Fig. 2.33.



**Fig. 2.33** Contour for an overhanging cliff

10. Contours do not have sharp turnings.

### 2.11.2 Uses of Contour Maps

Contour maps are used in many civil engineering works. Some of them are listed below.

1. To study the general topography of the country without doing any survey work.
2. For the site selection of various engineering works such as dams, canals, weirs, roads, railways, etc.
3. The section along any line can be drawn.
4. To determine the quantity of earthwork required for canals, roads, etc.
5. To determine the reservoir capacity.
6. To trace a contour gradient for road, canal and railway alignments.
7. To determine the intervisibility of points.

### Illustrative Examples

**Example 2.1** Convert the following WCB to RB

[May, June 2014]

1.  $20^\circ 30'$  2.  $176^\circ 10'$  3.  $220^\circ 30'$  4.  $295^\circ 40'$

**Solution** Referring to Table 2.2,

1. The given WCB is between  $0^\circ$  and  $90^\circ$ .

$$\text{So, } \text{WCB} = \text{RB } 20^\circ 30' = \text{N } 20^\circ 30' \text{E}$$

2. The given WCB is between  $90^\circ$  and  $180^\circ$ .

$$\begin{aligned} \text{So, } \text{RB} &= 180^\circ - \text{WCB} \\ &= 180^\circ - 176^\circ 10' = \text{S } 3^\circ 50' \text{E} \end{aligned}$$

3. Here, WCB lies between  $180^\circ$  and  $270^\circ$ .

$$\begin{aligned} \text{So, } \text{RB} &= \text{WCB} - 180^\circ \\ &= 220^\circ 30' - 180^\circ = \text{S } 40^\circ 30' \text{W} \end{aligned}$$

4. WCB lies between  $270^\circ$  and  $360^\circ$ .

$$\begin{aligned} \text{So, } \text{RB} &= 360^\circ - \text{WCB} \\ &= 360^\circ - 295^\circ 40' = \text{N } 64^\circ 20' \text{W} \end{aligned}$$

**Example 2.2** The WCB of a line is (i)  $\text{N } 25^\circ 30' \text{E}$  (ii)  $\text{S } 65^\circ 10' \text{E}$  (iii)  $\text{S } 32^\circ 30' \text{W}$  (iv)  $\text{N } 40^\circ 20' \text{W}$ . What will be the RB in each case?

**Solution** Referring to Table 2.3,

$$\begin{aligned} \text{(i) RB} &= \text{WCB} \\ &= \text{N } 25^\circ 30' \text{E} = 25^\circ 30' \end{aligned}$$

$$\begin{aligned} \text{(ii) WCB} &= 180^\circ - 65^\circ 10' \\ &= 114^\circ 50' \end{aligned}$$

$$\begin{aligned} \text{(iii) WCB} &= 180^\circ + \text{RB} \\ &= 180^\circ + 32^\circ 30' = 212^\circ 30' \end{aligned}$$

$$\begin{aligned} \text{(iv) WCB} &= 360^\circ - \text{RB} \\ &= 360^\circ - 40^\circ 20' = 319^\circ 40' \end{aligned}$$

**Example 2.3** The following are the observed fore bearings of the traverse sides:  $AB$ ,  $80^\circ 30'$   $BC$ ,  $150^\circ 15'$ ;  $CD$ ,  $270^\circ 20'$  and  $DE$ ,  $325^\circ 30'$ . Find their back bearings. [May, June 2009]

**Solution**

$$\text{BB} = \text{FB} \pm 180^\circ$$

$$\begin{aligned} \text{BB of } AB &= \text{FB} \pm 180^\circ \pm (+ \text{ve if } \text{FB} < 180^\circ \text{ and } -\text{ve if } \text{FB} > 180^\circ) \\ &= 80^\circ 30' + 180^\circ = 260^\circ 30' \end{aligned}$$

$$\text{BB of the line } BC = \text{FB} + 180^\circ$$

$$\begin{aligned}
 &= 150^\circ 15' + 180^\circ = 330^\circ 15' \\
 \text{BB of the line } CD &= \text{FB} - 180^\circ \\
 &= 270^\circ 20' - 180^\circ = 90^\circ 20' \\
 \text{BB of the line } DE &= \text{FB} - 180^\circ \\
 &= 325^\circ 30' - 180^\circ = 145^\circ 30'
 \end{aligned}$$

**Example 2.4** The FB of the lines are as follows:

*AB*, N 40° 45' E; *BC*, S 80° 20' E; *CD*, S 50° 30' W; *DE*, N 70° 15' W. Find their back bearings.

**Solution**

$$\begin{aligned}
 \text{BB} &= \text{FB with opposite letters} \\
 \text{BB of } AB &= \text{S } 40^\circ 45' \text{ W} \\
 \text{BB of } BC &= \text{N } 80^\circ 20' \text{ W} \\
 \text{BB of } CD &= \text{N } 50^\circ 30' \text{ E} \\
 \text{BB of } DE &= \text{S } 70^\circ 15' \text{ E.}
 \end{aligned}$$

**Example 2.5** Specimen page of level book with booking of BS, IS, and FS is as follows. Calculate the reduced levels (by height of collimation method). [Nov, Dec 2012]

**Solution** Refer to the table given below.

1. RL of H.I. at instrument station  $O_1$   
 $= \text{RL of BM} + \text{BS} = 100 + 1.350 = 101.350$
2. RL of intermediate points  
 $= \text{RL of H.I. at } O_1 - \text{IS or FS}$   
 $\text{RL of } B = 101.350 - 1.150 = 100.200$

Inst Station	Staff Station	B.S	IS	FS	H.I.	RL	Remarks
$O_1$	A	1.350	-	-	101.350	100.000	BMRL 100.00
	B		1.150			100.200	
	C		1.855			99.495	
	D		0.250			101.100	
$O_2$	E	1.750		1.500	101.600	99.850	C.P1
	F		2.185			99.415	
	G		2.205			99.395	
$O_3$	H	0.950		1.350	101.200	100.250	C.P2
	I			2.350		98.850	
		$\Sigma \text{BS} = 4.050$			$\Sigma \text{FS} = 5.200$		
		$\Sigma \text{BS} \sim \Sigma \text{FS} = 1.150$			Last RL $\sim$ First RL = 1.150		

- RL of C =  $101.350 - 1.185 = 99.495$   
 RL of D =  $101.350 - 0.250 = 101.100$   
 RL of E =  $101.350 - 1.500 = 99.850$
- RL of H.I. at instrument station  $O_2$   
 = RL of E + BS =  $99.850 + 1.750 = 101.600$
  - RL of intermediate points  
 = RL of H.I. at  $O_2$  – IS or FS  
 = R L. of F =  $101.600 - 2.185 = 99.415$   
 = RL of G =  $101.600 - 2.205 = 99.395$   
 = RL of H =  $101.600 - 1.350 = 100.250$
  - RL of H.I. at instrument station  $O_3$   
 = RL. of H + BS =  $100.250 + 0.950 = 101.200$
  - RL of the last point  
 = RL of H.I. at  $O_3$  – FS =  $101.200 - 2.350 = 98.850$

**Arithmetical Check**

$$\begin{aligned} \Sigma BS \sim \Sigma FS &= \text{Last RL} \sim \text{First RL} \\ 4.050 \sim 5.200 &= 98.850 \sim 100.00 \\ 1.150 &= 1.150 \end{aligned}$$

**Example 2.6** The specimen page of level book for BS, IS and FS is as follows: By rise and fall method, calculate the reduced levels.

**Solution**

Inst Station	Staff Station	BS	IS	FS	Rise	Fall	RL	Remarks
$O_1$	A	1.250	–	–	–	–	100.000	BMRL 100.00
	B		1.500			0.250	99.750	
	C		1.850			0.350	99.400	
	D		1.000		0.850		100.250	
$O_2$	E	1.150		2.150		1.150	99.100	C.PI
	F		2.250			1.100	98.000	
	G			0.750	1.500		99.500	
		$\Sigma BS = 2.400$		$\Sigma FS = 2.900$	$\Sigma Rise = 2.350$	$\Sigma Fall = 2.850$	$\text{Last RL} - \text{First RL} = 0.500$	

Difference of level between consecutive points:

$$\begin{aligned} A - B &= 1.250 - 1.500 = -0.250 \text{ (Fall)} \\ B - C &= 1.500 - 1.850 = -0.350 \text{ (Fall)} \\ C - D &= 1.850 - 1.000 = +0.850 \text{ (Rise)} \end{aligned}$$

$$D - E = 1.000 - 2.150 = - 1.150 \text{ (Fall)}$$

$$E - F = 1.150 - 2.250 = - 1.100 \text{ (Fall)}$$

$$F - C = 2.250 - 0.750 = + 1.500 \text{ (Rise)}$$

RL of any point = RL of the preceding point  $\pm$  Difference of level  
(Use + sign for rise and - sign for fall)

$$\text{RL of } B = 100.000 - 0.250 = 99.750$$

$$\text{RL of } C = 99.750 - 0.350 = 99.400$$

$$\text{RL of } D = 99.400 + 0.850 = 100.250$$

$$\text{RL of } E = 100.250 - 1.150 = 99.100$$

$$\text{RL of } F = 99.100 - 1.100 = 98.000$$

$$\text{RL of } G = 98.000 + 1.500 = 99.500$$

### Arithmetical check

$$\Sigma \text{ BS} \sim \Sigma \text{ FS} = \Sigma \text{ Rise} \sim \Sigma \text{ Fall} = \text{Last RL} \sim \text{First RL}$$

$$2.400 \sim 2.900 = 2.350 \sim 2.850 = 99.50 \sim 100.00$$

$$0.500 = 0.500 = 0.500$$

**Example 2.7** The following perpendicular offsets were taken at 10 metre intervals from a survey line to an irregular boundary line: 3.60, 2.80, 4.50, 8.25, 7.85, 6.45, 5.35. Calculate the area enclosed between the survey one and the boundary line by the trapezoidal rule and the Simpson's rule. [May, June 2012]

**Solution** In this problem, there are seven ordinates.

### By Trapezoidal Rule

$$\begin{aligned} A &= \frac{d}{2} [h_1 + 2(h_2 + h_3 + h_4 + h_5 + h_6) + h_7] \\ &= \frac{10}{2} [3.60 + 2(2.80 + 4.50 + 8.25 + 7.85 + 6.45) + 5.35] \\ &= 343.25 \text{ m}^2 \end{aligned}$$

### By Simpson's Rule

$$\begin{aligned} A &= \frac{d}{3} [h_1 + h_7 + 2(h_3 + h_5) + 4(h_2 + h_4 + h_6)] \\ &= \frac{10}{3} [3.60 + 5.35 + 2(4.50 + 7.85) + 4(2.80 + 8.25 + 6.45)] \\ &= 345.50 \text{ m}^2 \end{aligned}$$

**Example 2.8** A series of offsets were taken from a chain line to a curved boundary line at an interval of 5 m in the following order: 0, 3.25, 4.10, 6.45, 8.90, 5.75, 8.50, 0. Calculate the area between the chain line and the boundary line. [May, June 2010]

**Solution** Number of offsets = 8

$$d = 5 \text{ m.}$$

**By Trapezoidal Rule**

$$\begin{aligned} A &= \frac{d}{2} [h_1 + h_8 + 2(h_2 + h_3 + h_4 + h_5 + h_6 + h_7)] \\ &= \frac{5}{3} [0 + 0 + 2(3.25 + 4.10 + 6.45 + 8.90 + 5.75 + 8.50)] \\ &= 184.75 \text{ m}^2 \end{aligned}$$

**By Simpson's Rule**

To apply this rule, the number of ordinates should be odd. So, the last offset is ignored to calculate the area. Then, the area between last two offsets is calculated by applying the trapezoidal rule.

$$\begin{aligned} A &= \frac{d}{3} [h_1 + h_7 + 2(h_3 + h_5) + 4(h_2 + h_4 + h_6)] + \frac{6}{2} (h_7 + h_8) \\ &= \frac{5}{3} [0 + 8.50 + 2(4.10 + 8.90) + 4(3.25 + 6.45 + 5.75)] \\ &\quad + \frac{5}{2} (8.50 + 0) = 181.75 \text{ m}^2 \end{aligned}$$

### Short-Answer Questions

1. What are the two basic principles of survey?
2. What is meant by levelling?
3. What are the different types of bench marks?
4. What are the instruments used for levelling?
5. Name the two methods used for calculating the reduced levels of points.
6. Write the formula for calculating the area by Simpson's rule.
7. What is the length of a link in a metric chain of 30 m length?
8. Write short notes on the types of surveying.
9. Define: (a) Contour (b) Contouring.
10. What is meant by contour interval?
11. What do you understand by horizontal equivalent?
12. Differentiate between contour interval and horizontal equivalent.
13. How will you distinguish between a depression and a hill using a contour map?

### Exercises

1. Define surveying. Explain its importance for civil engineers.
2. What are the objectives of plane surveying?



3. Give the classification of surveys.
4. Explain the principles of surveying.
5. What are the advantages and disadvantages of chain surveying?
6. Describe a typical chain with a neat sketch.
7. What are the various instruments used in chain surveying?
8. Explain the principle of chain survey.
9. Which type of area is best suited for chain survey? Give reasons.
10. Define the following:
  - (a) Tie stations (b) Base line (c) Check line (d) Offset (e) Traverse
11. Differentiate the following:
  - (a) Open traverse and closed traverse
  - (b) Perpendicular offset and oblique offset
  - (c) Prismatic compass and surveyor's compass
  - (d) True bearing and magnetic bearing
  - (e) Whole circle bearing and reduced bearing
  - (f) Fore bearing and back bearing
12. What is local attraction? How is it detected and removed?
13. What are the advantages and disadvantages of compass surveys?
14. Convert the following WCB to RB
  - (a)  $66^{\circ} 30'$                       (b)  $130^{\circ} 15'$                       (c)  $205^{\circ} 20'$                       (d)  $265^{\circ} 10'$
  - (e)  $295^{\circ} 30'$                       (f)  $320^{\circ} 15'$
15. Convert the following RB to WCB
  - (a) N  $32^{\circ} 30'$  E                      (b) S  $42^{\circ} 40'$  E                      (c) S  $60^{\circ} 30'$  W                      (d) N  $72^{\circ} 50'$  W
16. Write the back bearings of the following fore bearings:
  - (a)  $60^{\circ} 10'$                       (b)  $130^{\circ} 30'$                       (c)  $200^{\circ} 15'$  C                      (d)  $300^{\circ} 20'$
17. Write the back bearings of the following fore bearings:
  - (a) N  $75^{\circ} 30'$  E                      (b) N  $60^{\circ} 30'$  W                      (c) S  $40^{\circ} 45'$  W                      (d) S  $55^{\circ} 20'$  W
18. What are the different types of levels used in levelling?
19. Define the following:

Level surface, horizontal plane, vertical plane, datum surface, reduced level, back sight, fore sight, intermediate sight, change point, bench mark.
20. Explain the principle of levelling.
21. Explain the following with neat sketches:
  - (a) Simple levelling (b) Differential Levelling
22. The BS reading at A is 2.355 m and the fore sight reading at B is 1.505 m. Find the level difference between A and B.
23. Compare the height of collimation method with the rise and fall method.

24. The following consecutive readings were taken with a levelling instrument on a continuously sloping ground. The RL of *A* was 100.000. Find the level difference between *A* and *B* by  
 (a) Height of collimation method                      (b) Rise and Fall method  
 Apply usual checks  
 0.585, 1.850, 2.550, 3.335, 0.865, 1.750, 2.880, 3.650
25. The following consecutive readings were taken with a dumpy level. 0.860, 1.350, 2.220, 0.780, 1.050, 2.780  
 The instrument shifted after the fourth reading. The RL of BM is 500.000 m. Calculate the reduced levels of the stations by the known two methods and apply the arithmetical checks.
26. A series of offsets were taken at 5 m intervals from a chain line to a curved edge.  
 1.50, 1.66, 2.25, 2.80, 1.75, 1.95, 0  
 Calculate the area between the chain line to a curved edge by the Simpson's rule and the trapezoidal rule.
27. Calculate the area between the chain line and the irregular boundary and the first and last offsets.
- |              |      |      |      |      |      |      |
|--------------|------|------|------|------|------|------|
| Distance (m) | 0    | 3    | 6    | 9    | 12   | 15   |
| Offset (m)   | 1.50 | 3.20 | 2.75 | 2.10 | 1.70 | 2.20 |
- Use Simpson's rule.
28. Show with neat sketches the characteristic features of contour lines.
29. Discuss in detail the uses of a contour map.

# Chapter 3

## **CIVIL ENGINEERING AND MATERIALS**

### **3.1 INTRODUCTION**

Engineers have probably contributed more to the shaping of civilisation than any other professional group. In every society, the role of engineers is to develop the technological application to meet practical needs. For example, the application of an electrical system is to provide power to a city, a water wheel is to run a mill, an artificial heart is to prolong life, etc. The systems that supply our food, water, fuel, power, transportation network, communication and other conveniences are the products of engineering skill. Despite the essential part engineers play in the above progress and in the well-being of humanity, their exact role is imperfectly understood.

Engineering is the art of converting knowledge into useful practical applications. An engineer is a person, who plays the key role in this process of conversion. Since engineering is the profession which serves people, their environment is an important consideration. Often, there have been difficulties in distinguishing engineers from scientists. It is difficult to determine where the work of the scientist ends and that of the engineer begins.

The basic distinction between the linked professions of science and engineering lies in their goals. Scientists aim to invent while engineers strive to use the inventions effectively to cater to the needs of mankind. For example, the German physicist Heinrich Hertz discovered radio waves while Guglielmo Marconi developed wireless telegraphy using radio waves, a feat of engineering. And after the scientific principles of nuclear fission were established, the hard work of creating atomic weapons and useful power plants was accomplished by electrical, chemical and mechanical engineers.

### **3.2 CIVIL ENGINEERING**

Civil engineering is that branch of engineering which aims to provide a comfortable and safe living for the people. Shelter, one of the primary needs of mankind, is provided by civil engineers. The efficient planning of water supply and irrigation systems increases the food production in a country. Shelters, apart from just being shelters, have been constructed by civil engineers to provide a peaceful and comfortable life. The engineering marvels of the world, starting from the pyramids to today's thin shell structures, are the results of the

development in civil engineering. Communication lines like roads, railways, bridges, etc, without which development is impossible, are fruits of civil engineers' work.

### **3.2.1 Scope of Civil Engineering**

Any discipline of engineering is a vast field with various specialisations. The major specialisations of civil engineering are listed below:

1. Structural engineering
2. Geotechnical engineering
3. Fluid mechanics, hydraulics and hydraulic machines
4. Transportation engineering
5. Water supply, sanitary and environmental engineering
6. Irrigation engineering
7. Surveying, levelling and remote sensing

### **3.2.2 Structural Engineering**

Structural engineering is the most important specialisation in civil engineering. The construction of a structure needs efficient planning, design and method of construction to serve the purpose fully. Generally there are five major steps in any construction project. These include the following:

1. Positioning and arranging the various parts of the structure into a definite form to achieve best utilisation.
2. Finding out the magnitude, direction and nature of various forces acting on the structure.
3. Analysing the structure to know the behaviour of the various parts of the structure subjected to the above forces.
4. Designing the structure such that its stability under the action of various loads is ensured.
5. Executing the work with selected construction materials and skilled workers.

### **3.2.3 Geotechnical Engineering**

For the efficient functioning of any structure built on earth, the behaviour of soil must be known. Geotechnical engineering gives the basic idea about the soil. This branch also deals with the following aspects:

1. The properties and behaviour of soil as a material under "soil mechanics".
2. The various types of foundations for a structure, for a machine, etc. and their suitability.

Geotechnical engineering also deals with the analysis, design and construction of foundation.

### 3.2.4 Fluid Mechanics, Hydraulics and Hydraulic Machines

Fluid mechanics deals with the properties and behaviour of fluids at rest or in motion. The principles of fluid mechanics can be applied to daily life as in the case of the flight of planes, the movement of fish in water, and the circulation of blood in the veins.

The design of hydraulic structures, such as dams and regulators, require the force exerted by water and the behaviour of water under pressure.

Machines which utilise the hydraulic energy are called hydraulic machines. For example, turbines use potential energy of water to generate power. Pumps are devices which utilise mechanical energy to lift water. The efficient working of the above machines depends upon the fluid behaviour which is dealt with in this discipline.

### 3.2.5 Transportation Engineering

The development of a nation mainly depends on the communication facilities available. A nation's wealth is measured in terms of the road and railway facilities available. There are three modes of transportation viz., land, water and air. This specialisation deals with the design, construction and execution of the communication routes.

The different branches of transportation engineering include the following: highway engineering deals with the planning and designing of roads, railway engineering deals with the railway tracks, harbour engineering deals with the harbours and airport engineering deals with the airports.

### 3.2.6 Water Supply, Sanitary and Environmental Engineering

Without food man can survive for days but not without water. The responsibility of providing potable (drinking) water to the public and disposing the waste water safely is that of a civil engineer. The sources of water are precipitation and underground water.

Water supply engineering deals with the location, collection of water, its treatment methods, tests for standard limits and efficient supply of water.

Used water, solid wastes, toxic wastes, etc., cannot be disposed directly since these affect the environment. Hence these have to be treated and tested for the standard limits and then disposed. Sanitary engineering deals with the collection of used water, their treatment methods and effective disposal which safeguards the whole world. The natural and artificial wastes generated and released into the atmosphere have upset the natural equilibrium. Anthropogenic or human-induced pollutants have overloaded the system.

The role of an environmental engineer is to build a bridge between biology and technology by applying all the techniques to the job of cleaning the debris. Environmental engineering deals with the methods of protecting the environment from the deleterious effects of human activity which would result in the improvement of environmental quality for the well being of mankind.

### 3.2.7 Irrigation Engineering

Irrigation may be defined as the process of supplying water by man-made methods for the purpose of land cultivation. Irrigation engineering includes the study and design of works related to the control of river water and the drainage of waterlogged areas. Thus, irrigation engineering deals with the controlling and harnessing of various resources of water, by constructing dams, reservoirs, canals, head works and distribution channels to the cultivable land.

### 3.2.8 Surveying, Levelling and Remote Sensing

Before starting any important civil engineering project, such as the construction of railways, highways, dams and buildings, it becomes necessary to have a detailed survey map showing accurate boundary of the project area. Surveying is defined as an art of collecting data for mapping the relative positions of points on the surface of the earth. Levelling is the process of determining the relative heights of the points on the surface of earth in a vertical plane.

The main purpose of the survey work is to prepare the plan of the object to be surveyed. Various instruments are used to measure and collect the necessary information to draw the plan. Remote sensing uses the technique of obtaining the data about an area by taking aerial photographs. The intelligent interpretation gives a clear picture of the terrain.

### 3.2.9 Functions of a Civil Engineer

Civil engineering incorporates activities such as construction of structures like buildings, dams, bridges, roads, railways, hydraulic structures, water supply and sanitary engineering.

Various functions of a civil engineer are listed below.

1. *Investigation* The first function of a civil engineer is to collect the necessary data that is required before planning a project.
2. *Surveying* The objectives of surveying is to prepare maps and plans to locate the various structures of a project on the surface of earth.
3. *Planning* Depending on the results obtained from investigation and surveying, a civil engineer should prepare the necessary drawing for the project with respect to capacity, size and location of its various components. On the basis of this drawing, a preliminary estimate should be worked out.
4. *Design* After planning, the safe dimension of the components required are worked out. With this dimension a detailed drawing is prepared for various components and also for the whole structure and a detailed estimate is also calculated.
5. *Execution* This function deals with the preparation of schedules for construction activities, floating of tenders, finalisation of contracts, supervision of construction work, preparation of bills and maintenance.

*6. Research and Development* In addition to the above mentioned works, a civil engineer has to engage himself in research and development to achieve economy and to improve the efficiency to meet the present and future needs.

### **3.3 CONSTRUCTION MATERIALS—BRICKS**

#### **3.3.1 Introduction**

As an engineer, one must know about the materials used in the construction site. All structures are constructed of materials known as engineering materials or building materials. It is necessary for an engineer to be conversant with the properties of such materials.

The service conditions of buildings demand a wide range of materials with specific properties. Hence the properties of the materials are to be studied properly to select suitable building materials. In this section and in the subsequent sections, the properties and uses of some building materials, such as bricks, stones, cement, concrete and steel are discussed.

The common brick is one of the oldest building materials and it is extensively used at present because of its durability, strength, reliability, low cost, etc. Bricks are obtained by moulding clay in rectangular blocks of uniform size, then by drying and burning these blocks in brick kilns.

#### **3.3.2 Qualities of Good Bricks**

[Nov, Dec 2010, 2011, 2014; May, June 2013;  
Apr, May 2015, Regulation 2008]

1. Bricks should have perfect edges, well-burnt in kilns, copper coloured, free from cracks with proper rectangular shape and of standard size ( $19 \times 9 \times 9$  cm).
2. Bricks should give a clear ringing sound when struck with each other.
3. Bricks must be homogeneous and free from voids.
4. The percentage absorption of water by weight should not be greater than 20 per cent for first-class bricks and 22 per cent for second-class bricks when soaked in cold water for 24 hours.
5. Bricks should be sufficiently hard, i.e., no nail impression must be present when scratched. The average weight of bricks should be 3–3.5 kg.
6. Bricks should not break when dropped from a height of 1 m.
7. Bricks should have low thermal conductivity and should be soundproof.
8. Bricks should not show deposits of salts when immersed in water and dried.
9. The minimum crushing strength of bricks must be  $3.5 \text{ N/mm}^2$ .

#### **3.3.3 Classification of Bricks**

[May, June 2009, 2010, 2014; Nov, Dec 2010, 2014;  
Apr, May 2015, Regulation 2008]

Bricks are classified based on the manufacturing process adopted. The classification is given as follows:

1. First-class bricks are table-moulded and of standard shape. These comply with all good qualities of bricks and are used for superior and permanent works.
2. Second-class bricks are ground-moulded and burnt in kilns. The surfaces of such bricks are rough and are slightly irregular in shape. Such bricks are used with a coat of plaster.
3. Third-class bricks are ground-moulded and are burnt in clamps. These bricks are not hard but rough with irregular and distorted edges. These give a dull sound when struck with each other. They are used for unimportant and temporary structures and at places where there is less rainfall.
4. Overburnt bricks with irregular shape and dark colour are classified as the fourth class bricks. These are used as aggregates for concrete in foundations, floors, roads, etc.

#### **3.3.4 Uses of Bricks** [Nov, Dec 2010; May, June 2013; Apr, May 2015, Regulation 2008]

1. Bricks are mainly used for the construction of walls.
2. Bricks when moulded in the shape of a gutter can be used as drains.
3. Bricks with cavities known as hollow bricks can be used for insulation purposes and because of their light weight they are more useful in speedy constructions.
4. Paving bricks prepared from clay containing higher percentage of iron can be used for pavements, since they resist abrasion in a better way.
5. Bricks with holes are used in multi-storeyed framed structures.
6. Fire bricks made of fire clay can be used as a refractory material.
7. Sand-lime bricks are used for ornamental work.
8. Bricks are used in the construction of compound walls, columns, etc. Broken pieces of bricks are used as aggregates in concrete.
9. Bricks of superior quality can be used in the facing of a wall.
10. Bricks are used in the construction of chimneys and other special works.

#### **3.3.5 Constituents of a Brick** [Nov, Dec 2011, 2014]

1. *Alumina* It is the chief constituent of clay. A good brick should have 20–30 per cent of alumina. This imparts plasticity to the earth.
2. *Silica* It exists in clay in a free or combined form. A good brick earth should contain about 50–60 per cent of silica. The presence of silica prevents cracking, shrinking and warping of raw bricks. It imparts uniform shape to bricks. The durability depends on proper proportion of silica.
3. *Lime* Up to 5 per cent of lime is desirable in good brick earth. It prevents shrinkage in raw bricks. Sand alone is infusible, but it fuses at kiln temperature due to the presence of lime. Bricks may melt and lose their shape due to excess of lime content.



4. *Oxide of iron* This gives the red colour to bricks. A small quantity of iron oxide up to 5 or 6 per cent is desirable.

5. *Magnesia* This imparts yellow tints to bricks and it reduces shrinkage.

#### *Advantages of using bricks*

The following are the advantages of bricks over other construction materials, like stone, concrete etc.,

- (a) Bricks are cheaper and easy to handle.
- (b) They are of standard size and hence easy to have proper bonding.
- (c) Consumes less mortar when compared to stone masonry.
- (d) Labour required for brick masonry is less.
- (e) Brick walls can be raised to a larger height, when compared to stone masonry.
- (f) Because of regular size the surface of wall will be plane and given a neat appearance.
- (g) Brick masonry consumes, less mortar for plastering.
- (h) Easy to drill holes for fixing service connection line.
- (i) Bricks have low thermal conductivity and high sound insulation properties.
- (j) They possess very high resistance to fire.
- (k) They are non-combustible and non-inflammable.

#### *Disadvantages of using bricks*

- (a) The compressive strength of brick is less compared to stone and concrete.
- (b) Water absorption is more than that of stone or concrete.
- (c) Only a selected variety of clay can be used for manufacture of bricks
- (d) Kilns are required to be constructed for manufacturing bricks.
- (e) It has got a very low tensile strength compared to other building materials.

### **3.3.6 Tests on Bricks**

The following are the field tests by judgment for assessing the quality of bricks.

#### *Field tests*

1. The bricks should be truly rectangular in shape with sharp edges and plane faces and of the same size.
2. They should be hard and well burnt and should give a metallic ringing sound when struck with a steel rod.
3. They should be of uniform red colour and of fine texture.
4. When the bricks are dropped on the ground from one metre height, they should not crack or break.
5. They should be free from cracks, fissures, pebbles or nodules of free lime.

*Lab Tests**1. Test for water absorptions*

- (a) 3 samples of clean well dried bricks are taken and their dry weight is found out individually.
- (b) The bricks are then immersed in water for 24 hours.
- (c) After 24 hours, the bricks are taken out, surface dried and weighed in a balance and wet weight found out.
- (d) If the wet weight of each bricks is  $W_2$ , the percentage water absorption of each brick
 
$$= \frac{W_2 - W_1}{W_1} \times 100$$
- (e) The average percentage of water absorption of three samples is the water absorption of the bricks.

Required standard The average absorption should not be greater than 20%. Too much of water absorption indicates under burnt condition and poor strength.

*2. Test for efflorescence (For the presence of salt)*

Salts like sulphates of calcium, magnesium, sodium and potassium present in the brick will cause efflorescence on the brick surface, when they get dissolved in water. Bricks containing too much of salt are less resistant to weathering and will have poor strength.

1. Three samples of bricks are immersed in good water for 24 hours.
2. After 24 hours, the bricks are taken out and examined for white patches of salt on the surfaces.
3. If the white patches of salt present are heavy, the bricks are poor and are to be rejected.
4. If the while patches present are small to medium, the bricks can be accepted.

*3. Test for compressive strength*

The load carrying capacity of bricks is increased, as the compressive strength increases.

- (a) Three samples of bricks are taken and immersed in good water for 24 hours.
- (b) After 24 hours of immersion, the bricks are taken out and surface dried.
- (c) Each brick is placed on the compression testing machine and the load on the brick is gradually increased until the brick fails. The failure load of each brick is found out.
- (d) Average failure load of the 3 bricks is the compressive strength of the bricks.

Requirement standards

1. Country Bricks  $\rightarrow$  3.5 to 5.0 N/mm<sup>2</sup>
2. II Class bricks  $\rightarrow$  5.0 to 7.5 N/mm<sup>2</sup>
3. I Class bricks  $\rightarrow$  7.5 to 12.5 N/mm<sup>2</sup>

### 3.3.7 Manufacture of Bricks

The following are the four processes involved in the manufacture of bricks.

1. Preparation of brick earth
2. Moulding of bricks
3. Drying of bricks
4. Burning of bricks

#### 1. Preparation of Brick Earth

Preparation of brick earth involves the following operations.

- (i) Removal of loose soil
- (ii) Digging, Spreading and Cleaning
- (iii) Weathering
- (iv) Blending
- (v) Tempering

(i) *Removal of loose soil* The top layer of the loose soil about 20cm depth contains lot of impurities and hence it should be taken out and thrown away.

(ii) *Digging, spreading and cleaning* The earth is then dug out from the ground. This earth is spread into heaps about 60 cm to 120 cm height. All the undesirable matters like stones, vegetable matter etc. are removed. Lumps of clay should be converted into powder form.

(iii) *Weathering* The earth is then exposed to atmosphere for softening. The period of exposure varies from weeks to full season.

(iv) *Blending* The clay is then mixed with suitable ingredients. It is carried out by taking a small portion of clay every time and by turning it up and down in vertical direction.

(v) *Tempering* This is done to make the whole mass of clay homogenous and plastic. Required water is added to clay and the whole mass is kneaded under the feet of men or cattle.

When bricks are manufactured on a large scale, tempering is usually done in a pug mill. A pug mill consists of a conical iron tub with cover at its top. A vertical shaft with horizontal arms is provided at the centre of iron tub. Several cutting blades are attached to this horizontal arm. The clay with water is put inside the mill and the vertical shaft is rotated by bullocks or steam, diesel or electric power. Due to the action of the horizontal arms the clay is thoroughly mixed and tempered.

#### 2. Moulding of Bricks

The tempered clay is then sent for the next operation of moulding. There are two methods of moulding.

- (i) Hand moulding
- (ii) Machine moulding

1. *Hand Moulding* This is done by a mould which is a rectangular box with open at top and bottom. It may be of wood or steel.

Following are the ways of hand moulding:

- (a) Ground moulding
- (b) Table moulding

- (a) *Ground moulding* First a small portion of ground is cleaned and leveled. Fine sand is sprinkled over it. Moulding is started from one end of the ground. Mould is dipped in water and kept on the ground and clay is pressed by hand nicely so that all is again dipped in water and it is placed just near the previous brick to prepare another brick. Process is repeated till the ground is covered with bricks. A mark of depth about 10 mm to 20 mm is placed on raw brick by a pallet during moulding. This mark is called as frog. After the bricks become sufficiently dry, they are sent for the next process of drying.
- (b) *Table moulding* This should be done by an experienced supervisor. The moulder stands near a table of size about 2 m × 1m. Clay, mould water pots, stock board, strikes and pallet boards are placed on this table. Bricks are moulded on the table and sent for the next process of drying.
2. *Machine moulding* When bricks are manufactured in huge quantity at the same spot then moulding is done by machines. These machines contain a rectangular opening of size equal to the length and width of the brick. The Tampered clay is placed in the machine and as it comes out through the opening under pressure it is cut into strips by wire fixed in frames. Arrangement is made in such a way that strips of thickness equal to that of the brick are obtained.
- The machine moulded bricks have sharp edges and corners, smooth external surface and uniform texture.

### 3. Drying of Bricks

After the bricks are moulded they are dried. This is done on specially prepared drying yards. Bricks are stacked in the yard with 8 to 10 bricks in each row. Bricks are dried for a period of 5 to 12 days.

During drying it must be protected from wind, rain and direct sun. Sometimes, bricks, are dried artificially by hot gases from kiln. But there is change of warping of bricks in case of artificial drying. After drying, the bricks are sent for the next operation of burning.

### 4. Burning of Bricks

Burning imparts hardness and strength to bricks and makes them dense and durable. It must be done carefully and properly because underburnt bricks remain soft and hence cannot carry loads and overburnt bricks become brittle and hence, break easily. Burning of bricks is done either in clamp or in kilns.

## 3.4 STONES

[May, June 2011]

Building stones are obtained from rocks. It is essential to have some knowledge about rocks in order to study the properties of stones. Rocks are mainly classified into igneous rocks, sedimentary rocks and metamorphic rocks. Igneous rocks are formed by the cooling of the molten material from beneath the earth's surface. Stones from these rocks are said to be harder. Granite which is widely used in building constructions is a good example.

Sedimentary rocks are formed by the deposition of weathering products on existing rocks. Deposits are in layers and when load is applied along the layers these rocks easily split.

Metamorphic rocks are formed by the change in character of the pre-existing rocks. These will be hard if the basic rock is an igneous rock.

### 3.4.1 Qualities of Good Stone

[Nov, Dec 2009, 2011; May, June 2011, 2013;  
Apr, May 2015]

1. The crushing strength of stone should be greater than  $100 \text{ N/mm}^2$ . All igneous rocks have a strength around  $100 \text{ N/mm}^2$  and some of the metamorphic rocks also satisfy this requirement. Sedimentary rocks have a lower strength.
2. Stones must be decent in appearance and be of uniform colour. Light coloured stones resist weathering action in a better way and hence preferred.
3. Stones must be durable. For the stones to be durable, their natural bed must be perpendicular to the direction of pressure.
4. Stones should be such that these can be easily carved and dressed. This property is opposed to strength and hardness but this depends upon the situation in which the stone is used.
5. For a good building stone its fracture should be sharp and clear.
6. If the stone is to be used in road work, it should be hard enough to resist wear and tear.
7. A good building stone must have a wear less than 3 per cent. If it is equal to 3 per cent, it is just tolerable while if it is more than 3 per cent it is not satisfactory.
8. Stones must be fire resistant, i.e., these must retain their shape when a fire occurs. Limestone resists fire up to about  $800^\circ\text{C}$ . Sandstones can resist fire in a better way. Argillaceous stones are poor in strength, but resist fire to some extent.
9. A good stone should not contain quarry sap which is nothing but moisture present in the stones.
10. A good building stone must have a specific gravity greater than 2.7.
11. A good stone must have a compact, fine, crystalline structure, strong and durable.
12. A good stone should not absorb water more than 0.6 per cent by weight. It must be capable of withstanding effects of atmosphere.
13. A good building stone must be acid resistant and free from any soluble matter.

Stones with exposed faces are acted upon by various atmospheric agencies such as wind, frost, living organisms, alternate wetness and drying, movement of chemicals and rain water. Stones can be prevented from the effects of these agencies if preserved properly. Coal tar, linseed oil, paint, paraffin, a solution of alum and soap, and a solution of baryta are some of the commonly used preservatives.

### 3.4.2 Uses of Stones

[Nov, Dec 2011]

Stones are used

1. In the construction of buildings from the very ancient times.
2. For foundations, walls, columns, lintels, arches, roofs, floors, damp proof courses, etc.
3. For facing works in brick masonry to give a massive appearance.
4. Since stones are hard, these can be used for pavements.
5. As a basic material for concrete, moorum of roads, calcareous cements, etc.
6. As ballast in railways, flux in blast furnaces, blocks in construction of bridges, piers, abutments, retaining walls, light houses, dams, etc.

### 3.4.3 Quarrying of Stones

Quarrying is the process of extracting stone blocks from existing rocks. It is done at some depth below the top surface of rock where the effects of weathering are not found. Quarrying of soft and hard rocks is done by the following methods:

1. Digging, heating or wedging: In soft rocks like limestone and marble, stones are obtained by digging, heating or wedging using hand tools, namely, pick-axes, hammers, chisels, etc.
2. Blasting: In hard and dense rocks, stones are obtained by blasting using explosives.

### 3.4.4 Dressing of Stones

Stones obtained after quarrying have rough surfaces and are irregular in shape and size. Dressing is the process of cutting the stones to a regular shape and size and the required surface finish. The purposes of dressing are:

1. To prepare the stones for a suitable size for any handling and transport.
2. To prepare the stones into a regular shape and pleasing appearance, with neat horizontal and vertical mortar joints between the adjacent stones.
3. To make hammer-dressed surface, tooled surface, polished surface, rubbed surface or cut-stone surface to suit a particular stone masonry.
4. To secure proper bedding in stone masonry.

### 3.4.5 Testing of Building Stones

To determine the suitability of stones for construction work, the following tests are conducted:

1. *Hardness test* Hardness of a stone is tested by a pen knife which will not be able to produce a scratch on a hard stone. Hardness number is determined using Mohr's scale of hardness.

2. *Impact Test* Impact test is carried out on an Impact Testing Machine to determine the toughness of a stone. In this test, a cylinder of 25 mm diameter and 25 mm height is taken out from the sample of the stone. A steel hammer of 2 kg weight is allowed to fall axially on the cylinder from 1 cm height for the first blow, 2 cm height for the second blow, 3 cm height for the third blow, and so on. The blow at which the specimen breaks is noted. If it is the  $n^{\text{th}}$  blow,  $n$  represents the Toughness Index of the stone.
3. *Test for crushing strength* In this test, a cube of sample stone of size 40 mm × 40 mm × 40 mm is tested in a compression Testing Machine. The rate of axial loading on the cube is 13.7 N/mm<sup>2</sup>/ minute. The maximum load at which the stone crushes is noted. Crushing strength of the stone per unit area is the maximum load at which its sample crushes or fails divided by the area of the bearing face of the specimen.

$$\text{That is, Crushing Strength of stone} = \frac{\text{Maximum load at failure}}{\text{Area of bearing face}}$$

4. *Fire resistance test* The stone, which is free from calcium carbonate, can resist fire. The presence of calcium carbonate in the stone can be detected by dropping a few drops of dilute sulphuric Acid which will produce bubbles.
5. *Electrical Resistance/ Water Absorption Test* As the electrical resistance of a wet stone is less, the stone should be non-absorbent. In this test, a stone of known weight is immersed in water for 24 hours. Then, it is weighed again. Percentage absorption of water by weight after 24 hours = (Increase in weight/ Original weight of the stone).
6. *Attrition test/Abrasion Test* Attrition test is carried out to determine the percentage of wear of stones used for the construction of road. It is carried out in Deval's Attrition Testing Machine.  
In this test, some known weight of stone pieces are taken and put in the Deval's Attrition Test Cylinder. The cylinder is rotated about its horizontal axis at the rate of 30 rpm for 5 hours. Then, the contents of the cylinder are sieved. The quantity of material retained on the sieve is weighted. Percentage Wear = (Loss in Weight/ Initial Weight) × 100.
7. *Acid Test* In this test, a specimen stone is kept for 1 week in the solution of sulphuric acid and hydrochloric acid. The corners of stones with high alkaline content turn roundish and loose particles will get deposited on its surface. Such types of stones are unsuitable for smoky atmosphere.
8. *Smith's test* This test indicates the presence of earthly matter in the stone. In this test, the sample of the stone is broken into small pieces and put into a test tube containing clear water. The test tube is then shaken vigorously. The directly colour will directly show the presence of argillaceous matter.
9. *Crystallization test* This test determines the durability or weathering quality of a stone. In this test, a sample of stone is immersed in the solution of sodium sulphate and dried in hot air. The process of wetting and drying is carried out for 2 hours.



The difference in weight, if any, is recorded. Little difference in weight indicates durability and good weathering quality of the stone.

10. *Microscopic test* This is a Geologist's test. In this test, the sample of stone is subjected to microscopic examination to study the following properties:
  - Mineral constitution
  - Texture of stone
  - Average grain size
  - Nature of cementing material
  - Presence of pores, fissures and veins.
11. *Freezing and thawing test* In this test, the specimen stone is kept in water for 34 hours. It is then placed in a freezing mixture at  $-12^{\circ}\text{C}$  for 24 hours. It is then thawed (warmed) to atmospheric temperature. The procedure is repeated several times and the behaviour of the stone is studied.

### 3.4.6 Types of Building Stones and their Uses

[May, June 2013]

1. *Granite* It is obtained from igneous rocks. It is hard, durable and available in different colours. It is highly resistant to weathering and has good crushing strength. It can take mirror-like polish.  
*Uses:* Granite is used for the construction of walls, columns and bridge piers. It is used for steps, sills and facing works. Also, it is used as ballast for road metal, rail metal, rail track and coarse aggregate for concrete. It is unsuitable for carving.
2. *Basalt and Trap* Basalt and Trap are also quarried from igneous rocks. These are hard, tough and durable and available in different colours.  
*Uses:* Basalt and Trap are used for constructing masonry floors, ornamental or decorative works and as road metal.
3. *Chalk* Chalk belongs to sedimentary variety. It is pure white stone, soft and easy to form powder.  
*Uses:* Chalk is used in preparing glazer's putty and also as colouring material in the manufacture of Portland cement.
4. *Limestone* It is derived from sedimentary rocks. It is easy to work. It consists of a high percentage of calcium carbonate.  
*Uses:* Limestone is used for the manufacture of cement. It is also used for floors, steps, walls and as road metal.
5. *Sandstone* It belongs to sedimentary variety. Its structure shows sandy grains. It is easy to work and dress. It is available in different colours. Its strength is low.  
*Uses:* It is used for different building works like facing works, carving, steps, walls, columns and as road metal.
6. *Laterite* It is derived from metamorphic rocks. It is sandy clay stone. It is porous and soft. It can easily be quarried in blocks. It contains high percentage of iron oxide.



**Uses** It is used for wall construction, rough stone masonry work and as road metal.

7. *Gneiss* Gneiss is metamorphic in nature. It is easy to work and splits into thin slabs.

**Uses** It is used as thin slabs for flooring, street paving, rough stone masonry work, etc.

8. *Marble* Marble is metamorphic. It can take good polish. It can be easily cut with saw and carved. It is available in different colours.

**Uses** Marble is used for flooring in the form of slabs, wall lining, facing work, steps, columns, etc. It is used for interior decoration and such ornamental works. Taj mahal is built fully of white marbles.

9. *Gravel* It is available in river beds in the form of pebbles of any kind of stone.

**Uses** It is used for surfacing road. It is also used in concrete.

10. *Slate* Slate is metamorphic. It is black in colour and can be split easily.

**Uses** It is used as roofing tiles, paving works and as damp-proof course in buildings.

11. *Quartzite* It is metamorphic. It is hard, durable, brittle and crystalline. It is difficult to work.

**Uses** It is used in rubble masonry, concrete aggregate, retaining walls and as road metal.

### 3.5 CEMENT

[Nov, Dec 2009]

Cement is obtained by burning at a very high temperature a mixture of calcareous and argillaceous materials. The calcined product is known as *clinker*. A small quantity of gypsum is added to the clinker and is pulverised into very fine powder known as cement. On setting, cement resembles a variety of sandstone found in Portland in England and is, therefore, called Portland cement.

#### 3.5.1 Good Qualities of Cement

[May, June 2010, 2013, 2014]

1. The colour should be uniform.
2. Cement should be uniform when touched. Cement should be cool when felt with hand. If a small quantity of cement is thrown into a bucket of water, it should sink.
3. Cement should be free from lumps.
4. Cement mortar at the age of three days should have a compressive strength of  $11.5 \text{ N/mm}^2$  and tensile strength of  $2 \text{ N/mm}^2$ . Also, at the age of seven days, compressive strength should not be less than  $17.5 \text{ N/mm}^2$  and tensile strength should not be less than  $2.5 \text{ N/mm}^2$ .

5. In cement, the ratio of percentage of alumina to that of iron oxide should not be less than 0.66.
6. When ignited, cement should not lose more than 4 per cent of its weight.
7. The total sulphur content of cement should not be greater than 2.75 per cent.
8. The weight of insoluble residue in cement should not be greater than 1.5 per cent.
9. Weight of magnesia in cement should not exceed 5 per cent.
10. The specific surface of cement as found from the fineness test should not be less than  $2250 \text{ mm}^2/\text{gm}$ .
11. The initial setting time of cement should not be less than 30 minutes and the final setting time shall be around 10 hours.
12. The expansion of cement should not be greater than 10 mm when soundness test is conducted.

### 3.5.2 Uses of Cement

[May, June 2010; Nov, Dec 2011, 2013, 2014]

1. Cement mortar, a mixture of cement and sand, is used for masonry work, plastering, pointing and in joints of pipes, drains, etc.
2. Cement is the binding material in concrete used for laying floors, roofs and constructing lintels, beams, weather sheds, stairs, pillars, etc.
3. Construction of important engineering structures, such as bridges, culverts, dams, tunnels, storage reservoirs, light houses and docks needs cement.
4. The manufacture of precast piles, pipes, garden seats, artistically designed urns, flower pots, dust bins, fencing post, etc., requires cement.
5. For underwater construction, quick setting cement is used. Rapid hardening cement is used for structures requiring early strength.
6. White and coloured cements are used for imparting coloured finishes to the floors, panels and exterior surfaces of buildings.
7. Expansive cements, which expands while setting, can be used in repair works of cracks.

### 3.5.3 Types of Cement

[Nov, Dec 2009; May, June 2010]

By changing the chemical composition and by using different raw materials and additives, many types of cements can be manufactured to cater to the need of the construction industry for specific purposes. Different types of cements are classified as Portland and Non-Portland cement.

1. *Rapid-hardening Cement* This cement is similar to the ordinary portland cement. As the name suggests, it develops strength rapidly. The rapid rate of strength development is attributed to the higher fineness of grinding. This cement is used where high strength is required instantly in initial stages. For example, repair works, early removal of formwork, etc.

2. *Sulphate-resisting Cement* Ordinary Portland cement has less resistance to the attacks of sulphates. This type of cement with higher silicate content is effective in fighting back the attacks of sulphates. This is used for the construction of sewage treatment works, marine structures and foundations in soils having large sulphate content.
3. *Low-heat Cement* This cement hardens slowly but produces less heat than the other cements while reacting with water. This can be used in mass concreting works like construction of dams, etc.
4. *Quick-setting Cement* This cement sets very quickly. This is due to the reduction of gypsum content in the normal Portland cement. It is used for underwater construction and also for grouting operation.
5. *Portland pozzolana Cement* Pozzolana is a siliceous material. Portland pozzolana cement is produced by grinding Portland cement clinker and pozzolana with gypsum. It produces less heat of hydration and offers greater resistance to the attack of aggressive water.
6. *High-alumina Cement* This cement generates high heat while reacting with water and causes high early strength development. So this cement can be used for generating high early strength in cold climates.
7. *Air-entraining Cement* This cement is produced by mixing a small amount of an air-entraining agent with ordinary Portland cement. By adding this, the properties of concrete can be changed and it also increases the frost resistance of hardened concrete.
8. *Masonry Cement* This cement has great plasticity, workability and water retentivity as compared with ordinary Portland cement. This is used for masonry constructions in making mortars and plasters.
9. *Expansive Cement* This cement produces an expansion in concrete during curing. As a result of expansion, cracks due to shrinkage of concrete are avoided. So, this can be used for filling the cracks by grouting and also to overcome cracks formation in reinforced cement concrete structures.
10. *Hydrophobic Cement* This is a water-repellent cement and is of great utility when the cement has to be stored for longer duration in wet climatic conditions. This cement also improves the workability of concrete.
11. *Coloured Cement* Coloured cement consists of ordinary portland cement with 5 to 10 per cent of pigment for colouring. This is used for aesthetic purposes.
12. *White Cement* The colour of this cement is white and it has the same properties of ordinary Portland cement. This can be used for architectural purposes and for manufacturing coloured concrete, flooring tiles, etc.
13. *High-strength Cement* Certain special works require high strength concrete. To improve the strength a higher content of  $C_3S$  and higher fineness are incorporated in ordinary Portland cement. This cement can be used for railway sleepers, prestressed concrete, precast concrete and air-field works.

### 3.5.4 Mortar

1. **Definition** The term mortar is used to indicate a paste prepared by adding required quantity of water to a mixture of binding material (cement or lime) and fine aggregate (sand). The above two components of mortar, namely, the binding material and fine aggregate are sometimes referred to as the matrix and adulterant respectively. The matrix binds the particles of the adulterant. The durability, quality and strength of mortar will mainly depend on the quantity and quality of the matrix. The combined effect of the two components of mortar is that the mass is able to bind the bricks or stones firmly.

#### 1.1 Grade of Cement

(a) **M33 Grade Cement** M refers to the mix, 33 refers the compressive strength of  $15 \times 15 \times 15$  cm size concrete cube at the age of 28 days—used for plastering work.

(b) **M43 Grade Cement** M refers to the mix, 43 refers the compressive strength of  $15 \times 15 \times 15$  cm size concrete cube at the age of 28 days—used for bricks or stone masonry walls constructions.

(c) **M53 Grade Cement** M refers to the mix, 53 refers the compressive strength of  $15 \times 15 \times 15$  cm size concrete cube at the age of 28 days—used for concreting works.

2. **Types of Mortars** The mortars are classified on the basis of the following:

- (a) Bulk density
- (b) Type of binding material
- (c) Nature of application
- (d) Special mortars

(a) **Bulk density** According to the bulk density of mortar in dry state, there are the following two types of mortars.

(i) **Heavy mortars** The mortars having bulk density of  $15 \text{ kN/m}^3$  or more are known as heavy mortars and they are prepared from heavy quartzs or other sands.

(ii) **Lightweight mortars** The mortars having bulk density less than  $15 \text{ kN/m}^3$  are known as lightweight mortars and they are prepared from light porous sands, pumice and other fine aggregates.

(b) **Type of binding material** The type of binding material used for a mortar is according to several factors such as expected working conditions, hardening temperature, moisture conditions, etc. According to the type of binding material, the mortars are classified into the following five categories.

(i) **Lime mortar** In this type of mortar, lime is used as binding material. The lime may be fat lime or hydraulic lime. The fat lime shrinks to a great extent and hence, it requires sand to the extent of about 2 to 3 times its own volume. The lime should be slaked before use. This mortar is unsuitable for water-logged areas or in damp situations.

The lime mortar has a high plasticity and it can be placed easily. It possesses good cohesiveness with other surfaces and shrinks very little. It is sufficiently durable, but it hardens slowly. It is generally used for lightly loaded above-ground parts of buildings.

(ii) **Surkhi mortar** This type of mortar is prepared by using only *surkhi* instead of sand or by replacing half of sand in case of fat lime mortar. The powder of *surkhi* should be fine

enough to pass BIS No.9 sieve and the residue should not be more than 10 per cent by weight.

*Surkhi* mortar is used for ordinary masonry work of all kinds in foundation and superstructure. But it cannot be used for plastering or pointing since *surkhi* is likely to disintegrate after some time.

(iii) Cement mortar In this type of mortar, cement is used as binding material. Depending upon the strength required and importance of work, the proportion of cement to sand by volume varies from 1:2 to 1:6 or more. It should be noted that *surkhi* and cinder are not chemically inert substances and hence, they cannot be used as adulterants with matrix as cement. Thus, only sand can be used to form cement mortar. The proportion of cement with respect to sand should be determined with due regards to the specified durability and working conditions. The cement mortar is used where a mortar of high strength and water-resisting properties is required such as underground constructions, water saturated soils, etc.

(iv) Gauged mortar To improve the quality of lime mortar and to achieve early strength, cement is sometimes added to it. This process is known as gauging. It makes lime mortar economical, strong and dense. The usual proportion of cement to lime by volume is about 1:6 to 1:8. It is also known as a composite mortar or lime-cement mortar and it can also be formed by the combination of cement and clay. This mortar may be used for bedding and for thick brick walls.

(v) Gypsum mortar These mortars are prepared from gypsum binding materials such as building gypsum and anhydrite binding materials.

**(c) Nature of application** According to the nature of application, the mortars are classified into the following two categories.

(i) Bricklaying mortars The mortars for bricklaying are intended to be used for brickwork and walls. Depending upon the working conditions and type of construction, the composition of masonry mortars with respect to the kind of binding material is decided.

(ii) Finishing mortars These mortars include common plastering work and mortars for developing architectural or ornamental effects. The cement or lime is generally used as binding material for ordinary plastering mortar. For decorative finishing, the mortars are composed of suitable materials with due consideration of mobility, water retention, resistance to atmospheric actions, etc.

**(d) Special mortars** Following are the various types of special mortars which are used for certain conditions.

(i) Fire-resistant mortar This mortar is prepared by adding aluminous cement to the finely crushed powder of fire-bricks. The usual proportion is one part of aluminous cement to two parts of powder of fire-bricks. This mortar is fire-resistant and is therefore used with fire-bricks, for lining furnaces, fire places, ovens, etc.

(ii) Lightweight mortar This mortar is prepared by adding materials such as saw dust, wood powder, etc. to the lime mortar or cement mortar. Other materials which may be added are asbestos fibres, jute fibres, coir, etc. This mortar is used for sound-proof and heat-proof construction.

(iii) Packing mortar To pack oil wells, special mortars possessing the properties of high homogeneity, water resistance, predetermined setting time, ability to form solidwater proof plugs in cracks and voids of rocks, resistance to subsoil water pressure, etc. have to be formed. The varieties of packing mortars include cement-sand, cement-loam and cement-sand-loam. The composition of packing mortar is decided by taking into consideration the hydrogeologic conditions, packing methods and type of timbering.

(iv) Sound-absorbing mortar To reduce the noise level, the sound-absorbing plaster is formed with the help of sound-absorbing mortar. The bulk density of such a mortar varies from 6 to 12 kN/m<sup>3</sup> and the binding materials employed in its composition may be Portland cement, lime, gypsum, slag, etc. The aggregates are selected from lightweight porous materials such as pumice, cinders, etc.

(v) X-ray shielding mortar This type of mortar is used for providing the plastering coat to walls and ceiling of X-ray cabinets. It is a heavy type of mortar with bulk density over 22 kN/m<sup>3</sup>. The aggregates are obtained from heavy rocks and suitable Admixtures are added to enhance the protective property of such a mortar.

3. *Properties of Mortar* Following are the properties of a good mortar:

1. It should be capable of developing good adhesion with the building units such as bricks, stones, etc.
2. It should be capable of developing the designed stresses.
3. It should be capable of resisting penetration of rain water.
4. It should be cheap.
5. It should be durable.
6. It should be easily workable.
7. It should not affect the durability of materials with which it comes into contact.
8. It should set quickly for speedy construction.
9. The joints formed by mortar should not develop cracks and they should be able to maintain their appearance for a sufficiently long period.

4. *Uses of Mortar* Following are the uses of mortar:

1. To bind the building units such as bricks, stones, etc. into a solid mass.
2. To carry out pointing and plaster work on exposed surfaces of masonry.
3. To form an even and soft bedding layer for building units.
4. To form joints of pipes.
5. To improve the general appearance of a structure.
6. To prepare moulds for coping, corbles, cornice, etc.
7. To serve as a matrix or cavity to hold coarse aggregates, etc.
8. To distribute uniformly the super incumbent weight from the upper layer to the lower layer of bricks or stones.
9. To hide the open joints of brickwork and stonework.
10. To fill up the cracks detected in the structure during maintenance process, etc.

5. *Selection of Mortar* Depending upon the nature of civil engineering work, suitable type of mortar should be selected or recommended. Table 3.1 shows the types of mortars to be used for various civil engineering constructions.





- (c) It should preferably be free from, clay, silt and fine dust. In case if the presence of them is unavoidable, they should not be present by more than 5% by weight (or 7% by volume)
- (d) Sand particles should be well graded and shall have sizes ranging from (150 micron) 0.15 m.m to 4.75 m.m.
- (e) The fineness modulus of sand shall be from 1.6 to 3.5.

### 3. Uses of Sand

[May, June 2012, 2014; Nov, Dec 2012]

- (a) It is used for making mortar and concrete
- (b) It is used for filling in the basement of buildings to receive the flooring concrete.
- (c) It is used as a binding material on the top of bituminous road.
- (d) It imparts mechanical strength to the mortar and prevents shrinkage and cracking of mortar while setting.
- (e) It forms major portion of mortar and reduces the cost of mortar.
- (f) It is mixed with expensive clay soils to stabilise them and prevent cracking of clay soils due to seasonal moisture changes.

### 4. Tests on Sand

The following tests are conducted to find out the suitability of sand.

- (a) Sieve analysis and fineness modulus test
- (b) Test for bulkage of sand
- (c) Test for silt content

(a) *Sieve analysis and fineness modulus test* The sand is sieved through 1. S. Sieves 4.75 mm 2.36 mm., 1.18 mm, 600 micron, 300 micron and 150 micron sieves and percentage retained in each sieve is found out.

Fineness modulus of sand = sum of the percentages retained in each sieve divide by 100.

Requirement A fineness modulus of 1.6 to 2.0 for sand for plastering mortar and a fineness modulus of 2.5 to 3.5 for sand for concrete and a fineness modulus of 2.0 to 3.0 for sand for masonry mortar may be sufficient.

(b) *Test for bulkage of sand: bulking of sand* The volume of dry sand will increase due to the presence of water in the sand up to about 25% of water content and thereafter it will decrease and become equal to its dry volume, when it is saturated with water. This increase in volume of sand is know as bulking of sand.

River sand will generally be wet and its volume will be more than the dry volume. Hence, it is necessary to known the bulking of sand to allow for its increase in volume in the volume batching of concrete and mortar. The increase is volume of sand is found out from the test for bulkage of sand.

Test for bulkage A small quantity of wet sand is poured into a glass measuring jar and rammed by a small rod of dia 6 mm. and level of sand is noted (say H1). Now water is poured into the cylinder until the sand is submerged and the glass jar is well shaken and



now the level of sand is noted. (say  $H_2$ ).  $H_2$  will be less than  $H_1$  and sand is saturated when it is submerged.

$$\text{Percentage bulkage of sand} = \frac{(H_1 - H_2)}{H_2} \times 100$$

(c) *Test of silt content* A small quantity of sand is poured into a glass measuring jar. Now water is poured until sand is well submerged in water. The glass jar is now shaken several times so that the silt and dust layer floats at the top of sand layer. The level of sand layer (excluding silt layer) is noted (say  $H_2$ ). The top level of silt layer above sand is noted. (say  $H_1$ ).

$$\text{The percentage of silt by volume} = \frac{(H_1 - H_2)}{H_2} \times 100$$

### 3.6 CEMENT CONCRETE

[May, June 2012; Apr, May 2015]

Cement concrete is a mixture of cement, sand, crushed rock and water which when placed in the skeleton of forms and allowed to cure, becomes hard such as stone. Concrete has attained the status of a major building material in all branches of modern construction and hence it is necessary to know the properties and uses of concrete.

#### 3.6.1 Properties of Concrete

[May, June 2009, 2014]

1. It has a high compressive strength and its strength depends on the proportion in which cement, sand, stones and water are mixed.
2. It is free from corrosion and there is no appreciable effect of atmospheric agents on it.
3. It hardens with age and the process of hardening continues for a long time after the concrete has attained sufficient strength.
4. As it is weak in tension, steel reinforcement is placed in it to take up the tensile stresses. This is termed as 'Reinforced Cement Concrete'.
5. It shrinks in the initial stage due to loss of water through forms. The shrinkage of cement concrete occurs as it hardens.
6. It has a tendency to be porous. This is due to the presence of voids which are formed during and after its placing.
7. It forms a hard surface, capable of resisting abrasion.

#### 3.6.2 Uses of Concrete

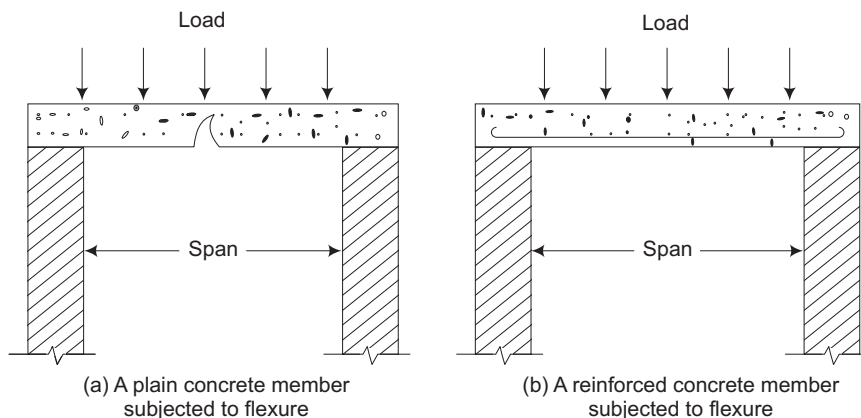
[May, June 2009, 2014]

1. Concrete can be made impermeable by using hydrophobic cement. This is used for the construction of RCC flat-roof slabs.
2. Coloured concrete is used for ornamental finishes in buildings, park lanes, separating lines of road surfaces, underground pedestrian crossings, etc.
3. Light weight concrete is used in multi-storeyed constructions.

4. No-fines concrete is one in which sand is eliminated. This can be used for *cast-in-situ* external load bearing walls of single and multi-storey houses, retaining walls, damp-proofing material, etc.
5. Concrete is mainly used in floors, roof slabs, columns, beams, lintels, foundations and in precast constructions.
6. It is used in massive structures, such as dams and bridges.
7. Concrete is used in the construction of roads, runways, playgrounds, water tanks and chimneys.
8. It is used in the construction of sleepers in railways.
9. Prestressed concrete is a relatively new type of concrete which is used in many constructions particularly in the construction of bridges.
10. Concrete trusses are also used in factory constructions.
11. Concrete is used in the construction of bunkers, silos, etc.
12. It finds a place in the construction of nuclear reactors because of its high shielding capacity for the radioactivity.
13. Thin economical shell construction are possible with the use of concrete.

### 3.6.3 Reinforced Concrete

Plain concrete is very weak in tension and cannot be used in the construction of lintels, roof slabs, beams, etc. in which the bottom fibres of them are subjected to tensile stresses. Figure 3.1 explains how a loaded beam or a slab is subjected to a flexural action when it is laid over an opening known as span. The top portion is compressed while the bottom portion is stretched. As concrete withstands compression but not tension, steel rods are embedded in the bottom portion to withstand the tension. A combination of concrete and steel is known as reinforced cement concrete and is widely used in various situations.



**Fig. 3.1** Flexure action

Reinforcing bars are available from 6–32 mm diameter and of 22 feet length. They may be of mild steel or Tor steel and may be plain or twisted.

### 3.6.4 Advantages of Reinforced Concrete

[May, June 2012]

1. Reinforced concrete is a versatile building material and can be used for casting members of any shape.
2. It has good resistance to fire, temperature and weathering actions.
3. RCC construction is easy and fast.
4. The component materials used for preparing RCC are easily available
5. Monolithic construction is possible with the use of RCC. This increases the stability and rigidity of the structure.
6. RCC is tough and durable.
7. Maintenance of RCC construction is very cheap.
8. With proper cover, RCC can be made free from rusting and corrosion.

### 3.6.5 Types of Concrete

[Nov, Dec 2014]

1. *Light-weight concrete* One of the disadvantages of normal concrete is the high self-weight which has a density of 2200 to 2600 kg/m<sup>3</sup>. This heavy self-weight causes heavy load and increases the haulage and handling costs. In order to make an economical concrete, attempts were made in the past to reduce the self weight of concrete. As a result the light weight concrete was developed whose density varies from 300–1850 kg/m<sup>3</sup>.

#### Advantages of light-weight concrete

- (a) It has low density.
- (b) It has low thermal conductivity.
- (c) It lowers haulage and handling costs.

#### Types of light-weight concrete

- (a) Light-weight aggregate concrete
  - (b) Aerated concrete
  - (c) No-fine concrete
- (a) Light-weight aggregate concrete By replacing the usual mineral aggregate by cellular porous or light weight aggregate, light-weight aggregate concrete can be produced. Light-weight aggregate can be classified into two categories namely natural and artificial light-weight aggregate.

Natural light-weight aggregates are

- (i) Pumice
- (ii) Diatomite

- (iii) Scoria
- (iv) Volcanic cinders
- (v) Saw dust
- (vi) Rice husk

Artificial light-weight aggregates are

- (i) Artificial cinders
- (ii) Foamed slag
- (iii) Bloated clay
- (iv) Sintered flyash

(b) **Aerated concrete** By introducing gas or air bubbles in mortar, aerated concrete can be produced. This concrete is a mixture of water, cement and finely crushed sand with air or gas introducing agents.

There are several ways in which aerated concrete can be manufactured. One important way is by the formation of gas or air bubbles using finely powdered metal (usually aluminium powder). Chemical reaction takes place in the concrete and finally large quantity of hydrogen gas is liberated which gives the cellular structure.

(c) **No-fine concrete** By omitting sand fraction from the aggregate, no-fine concrete can be produced. This concrete is made up of only single-sized aggregate of size passing of 20 mm and retained on 10 mm coarse aggregate, cement and water. The single sized aggregate makes a good no-fine concrete, which in addition gives large voids and hence is light in weight. It also offers an architecturally attractive look.

Out of the three main groups of light-weight concrete, the light-weight aggregate concrete and aerated concrete are more often used than the no-fine concrete.

2. **High-density concrete** The concrete whose unit weight ranges from about 3360–3840 kg/m<sup>3</sup> and which is about 50 per cent higher than the unit weight of normal concrete is known as high-density concrete.

The high-density concrete is mainly used in the construction of radioactive shields. High-density concrete is made by using such a heavy-weight aggregate whose specific gravity is more than 3.5. The aggregates used in this type of concrete should be clean, strong, inert and relatively free from deleterious material. Normally barite, magnetite, lemonite are used to make high-density concrete. To produce high density and high strength concrete, it is necessary to control the water – cement ratio, correct admixture and vibrators for good compaction.

3. **Polymer concrete** Air voids and water voids are present in the conventional concrete due to improper compaction, high water-cement ratio and some other causes. Due to compaction, these voids are found and the strength of the concrete is naturally reduced. There are number of methods available to reduce the air voids but none of these methods could really help to reduce the water voids. The impregnation of monomer and subsequent polymerisation is the latest technique adopted to reduce the inherent porosity of the

concrete, to improve the strength and other properties of concrete. This type of concrete is known as polymer concrete.

#### **Types of polymer concrete**

1. Polymer Impregnated Concrete (PIC)
2. Polymer Cement Concrete (PCC)
3. Polymer Concrete
4. Partially impregnated and surface coated polymer concrete

The following are the monomers normally used in polymer concrete.

1. Methyl methacrylate (MMA)
2. Styrene
3. Acrylonitrile
4. t-butyl styrene

Impregnation of these monomers improves the compressive strength, tensile strength, flexural strength of concrete and gives the concrete a high freeze thaw resistance and also high resistance to sulphate and acid attack.

#### **Applications of polymer impregnated concrete**

1. Prefabricated structural elements
2. Prestressed concrete
3. Marine works
4. Desalination plants
5. Nuclear power plants
6. Sewage works—pipes and disposal works
7. For water proofing of structures
8. Industrial applications

4. *Fibre-reinforced concrete* Plain concrete possesses a very low tensile strength, limited ductility and little resistance to cracking. Due to its poor tensile strength, internal microcracks are present in concrete which leads to brittle fracture. To improve the tensile strength of concrete one of the methods used is that of the conventional reinforced steel bars and the other way is by introducing fibres in the concrete and thereby increasing the inherent tensile strength of concrete. In order to reduce the microcracks, addition of small, closely spaced and uniformly dispersed fibres are used. These fibres act as crack arresters and substantially improve its static and dynamic properties. This type of concrete is known as Fibre Reinforced Concrete (FRC). Some of the fibres used are steel fibres, polypropylene, nylons, asbestos, coir, glass and carbon. The property of concrete may vary depending upon the type, diameter, length and volume of fibres.

Steel fibre is one of the most commonly used fibres. Most of the times round fibres are used. The diameter of such fibres may vary from 0.25–0.75 mm. The use of steel fibres may improve the flexural, impact and fatigue strength of concrete.

**Applications of fibre-reinforced concrete** Normally, FRC are used in air field, road pavements, industrial floorings, bridge decks, canal lining, explosive resistant structures, refractory linings, etc. It can also be used in pre-cast products like pipes, boats, beams, staircase steps, wall panels, roof panels, manhole covers, etc.

### 3.6.6 Testing of Fresh and Hardened Concrete

[Apr, May 2015]

**1. Testing of fresh concrete** Fresh concrete or plastic concrete is a freshly mixed material which can be moulded into any shape. The most important property of fresh concrete is its workability.

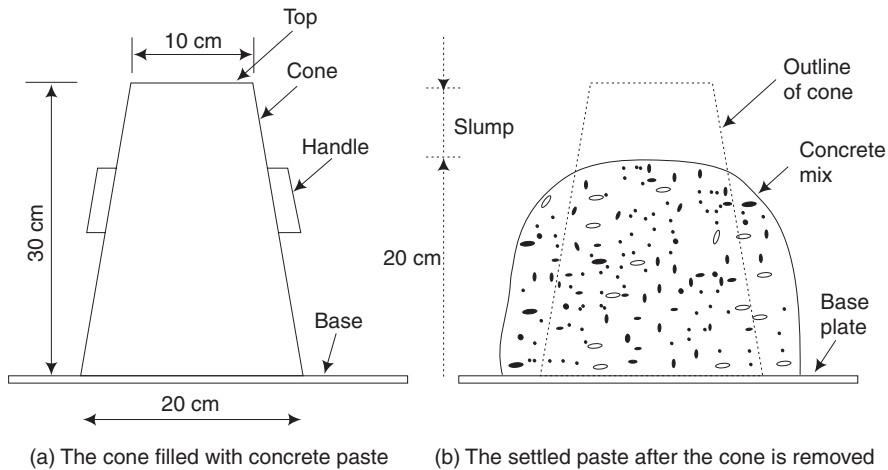
**Workability** The term *workability* is used to describe the ease or difficulty with which the concrete is handled, transported and placed between the forms with minimum loss of homogeneity. However, this gives a very loose description of this vital property of concrete which also depends on the means of compaction available. For instance, the workability suitable for mass concrete is not necessarily sufficient for thin, inaccessible or heavily reinforced sections. The compaction is achieved either by ramming or vibrating. The workability, as a physical property of concrete alone irrespective of a particular type of construction, can be defined as the amount of useful internal work necessary to produce full compaction.

If the concrete mixture is too wet, the coarse aggregates settle at the bottom of the concrete mass and the resulting concrete has a non-uniform composition. On the other hand, if the concrete mixture is too dry, it will be difficult to handle and place it in position. To correlate these two conflicting conditions proportions of various components of concrete mixture should be carefully decided. The important facts in connection with workability are as follows:

1. If more water is added to attain the required degree of workmanship, it results into concrete of low strength and poor durability.
2. If the strength of concrete is not to be affected then, the degree of workability can be obtained in following ways:
  - (i) by slightly changing the proportions of fine and coarse aggregates, in case the concrete mixture is too wet.
  - (ii) by adding a small quantity of water cement paste in the proportion of original mix, in case the concrete mixture is too dry.
3. A concrete mixture for one work may prove to be too stiff or too wet for another work. For instance, stiff concrete mixture will be required in case of vibrated concrete work while wet concrete mixture will be required for thin sections containing reinforcing bars.
4. The workability of concrete is affected mainly by water content, water–cement ratio and aggregate-cement ratio.
5. The workability of concrete is also affected by the grading, shape, texture and maximum size of the coarse aggregates used in the mixture.

In order to measure the workability of concrete mixture, various tests are developed. Tests such as *flow test* and *compaction test* are used mostly in laboratory. The *slump test*, which is commonly used in the field, is briefly described below. It should, however, be remembered that numerous attempts have been made to correlate workability with some easily determinable physical measurement. Although they may provide useful information within a range of variation in workability but none of these tests is fully satisfactory. At the same time, the slump test does not measure the workability of concrete. It is simply useful in detecting variations in the uniformity of a mix of given nominal proportions.

### Slump test



**Fig. 3.2** *Slump test*

The standard slump cone, as shown in Fig. 3.2 is placed on the ground. The operator holds the cone firmly by standing on the foot pieces. The cone is filled with about one-fourth portion and then rammed with a rod which is provided with bullet nose at the lower end. The diameter of the rod is 16 mm and its length is 60 mm. The strokes to be given for ramming vary from 20 to 30. The remaining portion of the cone is filled in with similar layers and then the top of concrete surface is struck off such that the cone is full of concrete. The cone is then gradually raised vertically and removed. The concrete is allowed to subside and then the height of concrete is measured. The slump of concrete is obtained by deducting the height of concrete after subsidence from 30 cm.

Table 3.2 shows the recommended slumps of concrete for various types of concrete and Table 3.3 shows the classification of concrete mixes on the basis of slump.

## 2. Testing of Hardened Concrete

**1. Compressive Strength** It may be defined as the maximum compressive load that can be taken by concrete per unit area. It has been shown that with special care and control, concrete can be made to bear loads as high as  $80 \text{ N/mm}^2$  or even more. In practice, however,

concrete with compressive strength between 10–50 N/mm<sup>2</sup> can be easily made on the site for common type of construction.

**Table 3.2** Recommended slumps of concrete

S.No.	Type of concrete	Slump
1.	Concrete for road construction	20 to 40 mm
2.	Concrete for tops of curbs, parapets, piers, slabs and walls that are horizontal	40 to 50 mm
3.	Concrete for canal linings	70 to 80 mm
4.	Concrete for arch and side walls of tunnels	90 to 100 mm
5.	Normal RCC work	80 to 150 mm
6.	Mass concrete	25 to 50 mm
7.	Concrete to be vibrated	10 to 25 mm

**Table 3.3** Classification of concrete mixes

Slump	Nature of concrete mix
No slump	Stiff and extra stiff mix
From 10 to 30 mm	Poorly mobile mix
From 40 to 150 mm	Mobile mix
Over 150 mm	Cast mix

The compressive strength, also called the crushing strength, of concrete is determined by loading axially cube shaped (or cylindrical shaped) specimens made out of the concrete. The tests are carried out 3 days, 7 days and 28 days after the casting of the samples. It is the 28 days compressive strength which is taken as a standard value for concrete of a particular batch.

It has been observed that the compressive (crushing) strength of concrete is influenced by a very large number of factors. The most important of these factors are the following:

(i) **Types of cement** The composition, quality and age of the cement used in making concrete influences its strength. Thus, cement that has been stored for considerable time make concrete of lower strength despite all the other factors being the same. Cement with higher proportions of tri-calcium silicates produce concrete that show higher strengths, at least in earlier stages. Similarly, finer the particle size of the cement, higher is the ultimate compressive strength.

(ii) **Nature of aggregates** Sand and coarse aggregates are the other two essential components of concrete. A good bond between cement and the aggregate is possible only when the latter have sharp edges, clean surfaces and rough texture. Smooth and rounded aggregates result in comparatively poor bonds. Similarly, the aggregates used in concrete making should have in themselves, good compressive strength. For example, if chalk (very soft limestone) is used in making concrete instead of massive limestone, the resulting concrete will be weak in compressive strength because of the poor strength of the aggregate.



(iii) **Water-cement ratio** The compressive strength decreases, in general, with increasing water-cement ratio (other things being the same). Hence, when minimum water just to ensure complete hydration of the cement is used, the resulting concrete will give maximum compressive strength on proper compaction.

(iv) **Curing conditions** Great importance is attached to proper curing of concrete after its laying for obtaining maximum compressive strength. Incomplete curing and intermittent drying of concrete during the curing period may cause a loss in the compressive strength to the extent of 40 per cent or even more.

(v) **Weather conditions** The same concrete placed in different weather conditions like extremely cold, dry and hot, may develop different strength values. The cause is related to incomplete hydration of the cement in the concrete.

(vi) **Admixtures** Certain admixtures are added to the concrete at the mixing stage for some specific purposes. It has been observed that certain admixtures especially calcium chloride, increase the compressive strength. Some other admixtures (e.g. air entraining agents) however, affect the compressive strength adversely if proper controls are not maintained on water-cement ratio.

(vii) **Methods of preparation** Improper mixing of the concrete and careless transport and storing may result in poor strength despite best cement and aggregates used in it. It is the workmanship that determines the quality of the concrete work in ultimate analysis. A skilled worker can produce best concrete works despite some other deficiencies. An incompetent worker, however, may spoil the entire work despite being given the best designed concrete mix. The voids left in the concrete on compaction and curing have a profound influence on the strength of the concrete.

**2. Tensile strength** Plain concrete (without steel reinforcement) is quite weak in tensile strength which may vary from 1/8 to 1/20 of the ultimate compressive strength. It is primarily for this reason that steel bars (reinforcement) are introduced into the concrete at the laying stage so as to get a concrete which is very strong in compression as well as in tension. In plain concrete, tensile strength depends to a great extent on the same factors as the compressive strength does.

Tensile strength of concrete becomes an important property when it is to be used in road making and runways. It is determined by using indirect methods.

In one of such methods, it is derived from the *flexural strength tests*. In these tests, a beam of concrete is cast in standard dimensions depending upon the nominal size of the aggregate. The beam is properly cured and tested after 28 days. It is simply supported from below and equally loaded at its one-third span points from both supports till failure. The bending moments, obviously, induce compressive stresses at the top and tensile stresses at the bottom of beam. The beam fails in tension. Modulus of rupture or flexural strength is then calculated by using the usual beam formula given below:

$$f_c = \frac{FL}{bd^2}$$

where

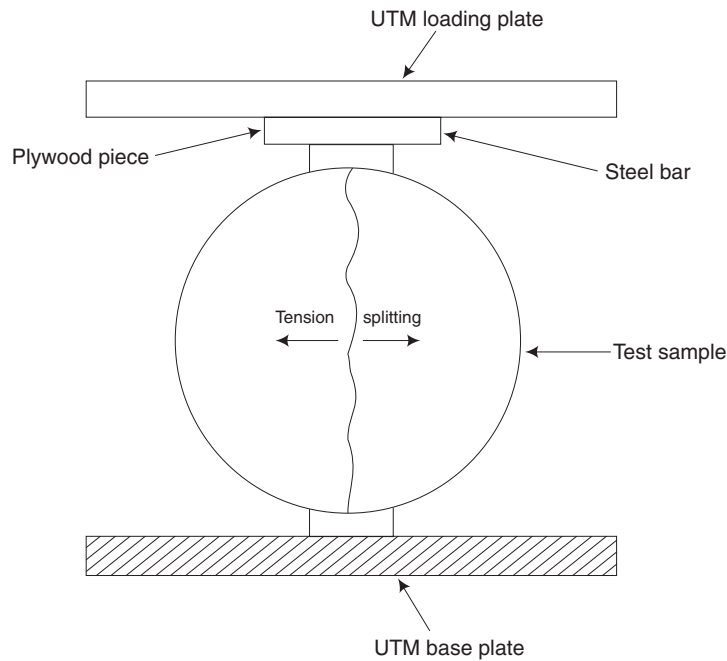
- $f_c$  = flexural strength
- $F$  = maximum applied load
- $L$  = distance between supports
- $b$  = breadth
- $d$  = depth

In the second indirect method, called the *split cylinder method* as shown in Fig. 3.3, a cylinder of specified dimensions is made to fail under tension by applying compressive load across the diameter. This is termed as splitting tensile strength. The testing machine is adjusted to distribute the load along the entire length of the cylinder. From the load at failure, tensile strength is calculated using the following relationship.

$$f_t = \frac{2P}{\pi d}$$

where

- $f_t$  = splitting tensile strength in  $\text{N}/\text{mm}^2$
- $P$  = maximum applied load in N
- $l$  = length of the cylinder (mm)
- $d$  = diameter of the cylinder (mm)



**Fig. 3.3** Split cylinder testing for tensile strength

For approximate use, tensile strength of concrete may be taken between 10–12 per cent of its (cube) compressive strength.

3. *Non-destructive tests for concrete* Estimation of concrete or member strength is the most common requirement of *in-situ* investigations but unfortunately, none of the available methods can be used to provide a reliable value in every situation.

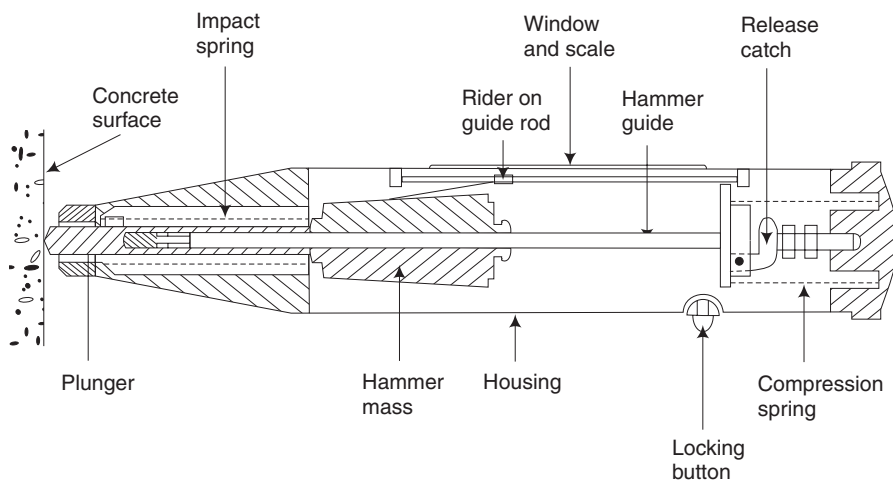
Non-destructive tests with all their limitations play a vital role in strength determination. Two such test methods normally available are the following:

- (a) Rebound test method
- (b) Ultrasonic method

#### (a) Rebound test method

**Rebound test equipment and operation** A Swiss engineer, Ernst Schmidt, developed a practicable rebound test hammer in the late 1940s for the first time and modern versions are based on this test. Figure 3.4 shows the basic features of a typical type of hammer which weighs less than two kg.

The spring-controlled hammer mass slides on a plunger within a tubular housing. The plunger rotates against a spring when pressed against a concrete surface and this spring is automatically released when tensioned, causing the hammer mass to impact against the concrete through the plunger. When the spring controlled mass rebounds it takes with it a rider which slides along a scale and is visible through a small window in the side of the casing. The rider can be held in position on the scale by depressing the locking button. The equipment is very simple to use. The scale reading is known as the rebound number and is an arbitrary measure as it depends on the energy and the mass used. With this number, the compressive strength of concrete can be obtained from the graph attached with the instrument.

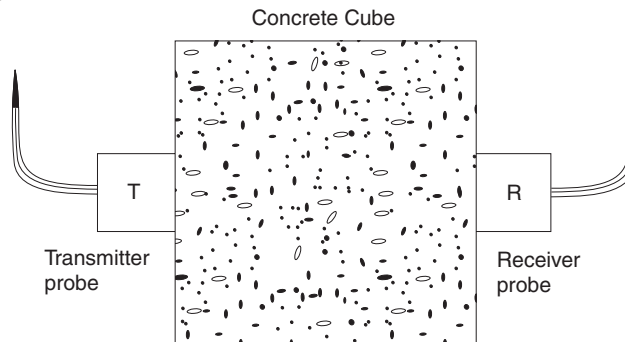


**Fig. 3.4** *Typical rebound hammer*

Procedure The reading is very sensitive to local variations of the concrete, especially aggregate particles close to the surface. It is therefore necessary to take several readings at each test location and to find their average between 9 and 25 readings taken over an area not exceeding 300 mm with the impact points not less than 20 mm from each other or from the edge. The use of grid to locate these points reduce operator bias. The surface must be smooth, clean and dry and properly formed. In case rough surfaces are unavoidable they should be rubbed smooth with carborundum stone.

**(b) Ultrasonic method** In ultrasonic pulse velocity method, the time of travel of an ultrasonic pulse, passing through the concrete to be tested is measured. This is shown in Fig. 3.5. The pulse generator circuit consists of an electronic circuit for generating pulses and also a transducer which transforms these electronic pulses into mechanical energy having vibration frequencies in the range of 15–50 kHz. The time of travel between initial onset and the reception of the pulse is measured electronically. The path length between transducer when divided by the time of travel, gives the average velocity of wave propagation.

With the velocity of wave propagation, the quality and compressive strength of concrete can be obtained as per the classification in Table 3.4.



**Fig. 3.5** Direct transmission of ultrasonic waves

**Table 3.4** Quality gradings for concrete

Velocity km/s	Classification (Quality)	Overall in situ compressive strength N/mm <sup>2</sup>
4.0 and above	Very good	30 to 35
3.5 to 4.0	Good	25 to 30
3.0 to 3.5	Medium	20 to 25
3.0 and below	Poor	15 to 20

### 3.7 STEEL SECTIONS

[May, June 2011, 2014; Nov, Dec 2012]

Steel is very ductile and has elastic properties. Mild steel having a carbon content of 0.1–0.25 per cent is used for structural work. To be used in construction works steel must be available in a certain forms. These are called market forms and are discussed as follows.

### 3.7.1 Bars

Bars are the common form of steel in building construction. These may have either round or square cross sections. Square sections of size 5–32 mm are commonly used in building works. These square bars are used as railings in buildings and for grillwork. Square bars are designated as ISSQ (an acronym for Indian Standard Square) bars.

Bars are available in lengths varying from 10–12 m. The common round bars vary from 6–32 mm in diameter. These round bars are used in reinforced concrete and reinforced brickwork constructions. Certain special type of bars having slight projections on its surface are also used as reinforcement. These are called as deformed bars. Their size generally varies from 8–32 mm.

### 3.7.2 Plates

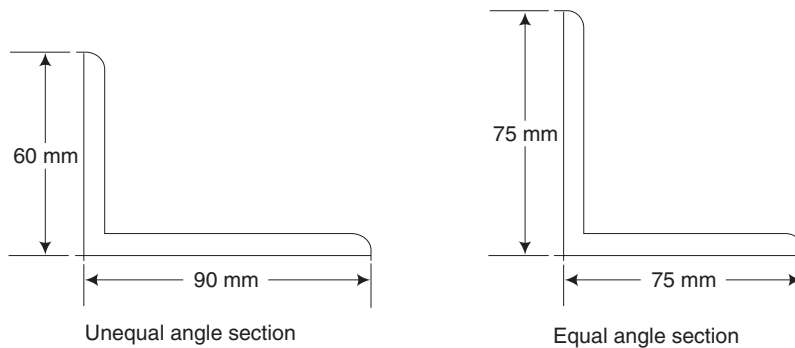
Rolled plates have a maximum area of 30 m<sup>2</sup>. The thickness of the plates varies from 5–28 mm. Plates thinner than 5 mm are called *sheets*. Larger plates are thicker at the centre than at the edges. These plates are used as webs and flanges for deep beams, column flanges, column bases, etc.

### 3.7.3 Flats

These are rolled as in the case of plates but are much longer and have shorter width. The width varies from 18–500 mm and the thickness varies from 3–80 mm. Flats are costlier than plates. These are also used in grill works and railings.

### 3.7.4 Angle Sections

Angle sections may be of equal legs or unequal legs as shown in Fig. 3.6. Equal angle sections are available in sizes varying from 20 mm × 20 mm × 3 mm to 200 mm × 200 mm × 25 mm. The corresponding weights per metre length are 9.0 N and 736.0 N respectively. Unequal angle sections are available from 30 mm × 20 mm × 3 mm to 200 mm × 150 mm × 18 mm. The weights per metre length are 11.0 N and 469.0 N respectively.



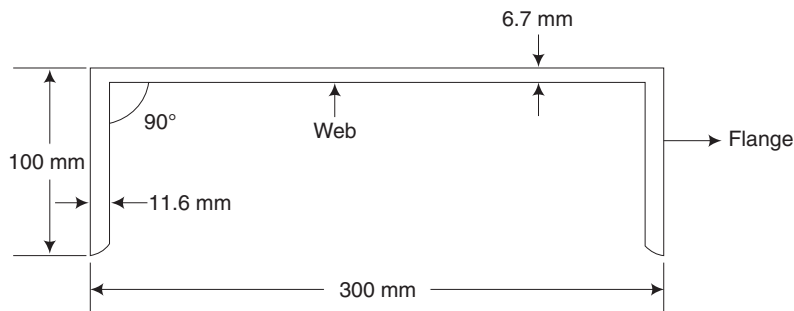
**Fig. 3.6** Angle sections

Angle sections are used in the construction of steel roof trusses, filler joist floors, steel columns, steel beams and as stiffeners in huge girders. They are mainly used in the construction of steel bridges.

### 3.7.5 Channel Sections

A channel section consists of a web with two equal flanges as shown in Fig. 3.7. Typically a channel section is designated by the height of web and the width of flange. These sections are available from 100 mm × 45 mm to 400 mm × 100 mm with weight per metre length of 58.0 N and 494.0 N respectively.

Channel sections are widely used as structural members of the steel-framed structures. These are used in the construction of built-in columns, crane girders, beams and steel bridges.

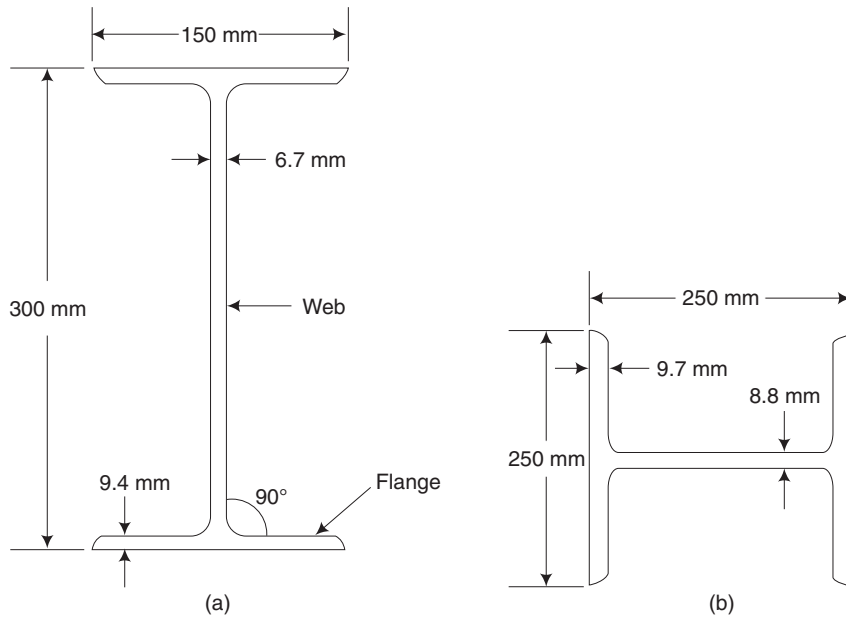


**Fig. 3.7** Channel section

### 3.7.6 I-sections

These are popularly known as rolled steel joists (RS joists) or beams. An I-section consists of two flanges connected by a web as shown in Fig. 3.8 (a). It is designated by overall depth, width of flange and weight per metre length. These are available in various sizes from 75 mm × 50 mm at 61 N/m to 600 mm × 210 mm at 995 N/m. Wide flange beams are available in sizes varying from 150 mm × 100 mm at 170 N/m to 600 mm × 250 mm at 1451 N/m. Sections suitable for columns are available in H-sections which vary in sizes from 150 mm × 150 mm at 271 N/m to 450 mm × 250 mm at 925 N/m as shown in Fig. 3.9 (b).

RS joists are economical in material and are suitable for floor beams, lintels, columns, etc. The economic use of material is achieved by concentrating the material in the two flanges where bending stresses are maximum. Heavy weights with unequal I-sections are used as rails.



**Fig. 3.8** (a) *I-section*, (b) *H-section*, (c) *T-section*

### 3.7.7 T-Sections

A T-section consists of a web and a flange as shown in Fig. 3.8 (c). It is designated by its overall dimensions and thickness.

The sections are available in sizes varying from 20 mm × 20 mm × 3 mm to 150 mm × 150 mm × 10 mm with corresponding weights of 9.0 N/m and 228.0 N/m respectively. Special T-sections with unequal sides, bulbs at the bottom edge of web, etc. are also available.

T-sections are widely used as members of steel roof trusses and to form built-up sections. These are also used in T-connections in steel water tanks. These sections are used in steel chimneys, steel bridges, etc.

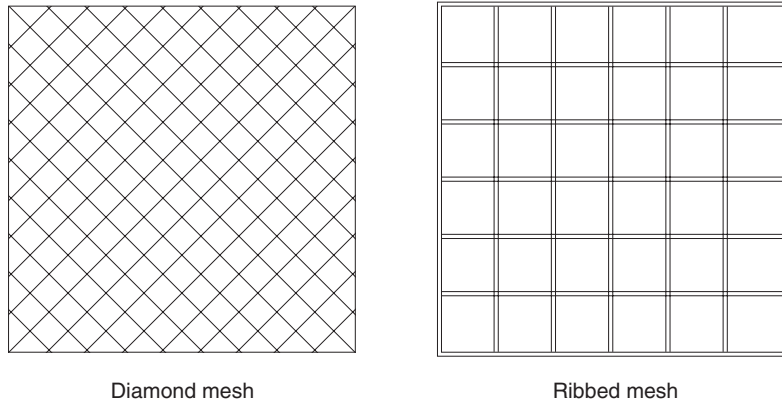
In addition to the above sections, miscellaneous sections such as acute and obtuse angle sections, trough sections and Z-sections are also available. These sections are used to a limited extent in the structural steel work.

### 3.7.8 Expanded Metal

This material is formed by cutting and expanding either plain sheets or ribbed sheets of steel. The manufactured sheets are known as diamond mesh or rib mesh as shown in Fig. 3.9. Diamond mesh has sizes from 30–150 mm across the shorter length of the mesh and is obtainable from 1–3 m long and 5 m wide.

Expanded metal is used as a ferrocement reinforcement for concrete, plaster, pavement formation and as partition wall interiors.

Welded fabric which is also known as BRC fabric is a rectangular or square mesh with an aperture of about 75-300 mm. It is made of high tensile, mild steel wires in rolls or sheets as shown in Fig. 3.9.



**Fig. 3.9** Expanded metal

### 3.7.9 Steel as a Reinforcing Material

#### 1. Reasons for steel to be considered as a good reinforcing material

- (i) It develops a good bond with concrete and hence the stresses are transferred from one material to another.
- (ii) It has high tensile strength.
- (iii) It has high modulus of elasticity.
- (iv) Its temperature coefficient of expansion and contraction is same as that of concrete and so thermal stresses do not develop.
- (v) It is cheap and readily available.

#### 2. Choice of reinforcing steel

- (a) Reinforcing steel should be chosen such that it can be incorporated in the concrete to form a monolithic structure.
- (b) The reinforcing steel should be of the smaller section to avoid stress concentration.

#### 3. Forms of reinforcing steel

- (a) **Round bars** It is a commonly adopted form of reinforcing steel.
- (b) **Flat bars** It is more useful in tanks and pipes as they increase effective thickness.
- (c) **Square bars**
- (d) **Reinforcement in the form of fabric** It is used in roads, walls and floor slabs where tensile stresses develop more than in one direction. It is more convenient than placing individual bars at right angles to each other. It claims more tensile strength, better bond with concrete, checking of shrinkage and temperature cracks.



#### 4. Types of reinforcing steel

- (a) Mild steel
- (b) High yield strength deformed bars or Tor steel

##### (a) Mild Steel

1. Stress-strain curve From the tension test on mild steel, load vs extension or stress-strain diagram is plotted as in Fig. 3.10.

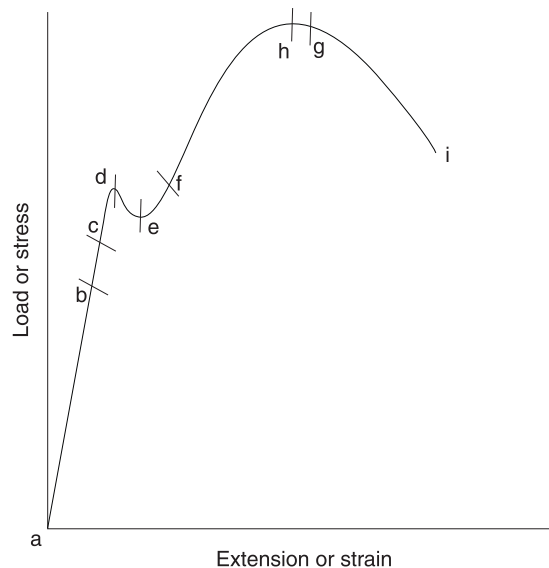
(i) Elastic stage (a to c) Load is increased gradually in the region (a to b) where the stress is directly proportional to strain. That is material obeys Hooke's law works up to b which is known as the limit of proportionality.

Beyond the limit of proportionality, material ceases to obey Hooke's law, i.e., the curve falls away from straight line *ab* produced. However, material remains elastic up to *c* which is called elastic limit though for all practical purposes *b* and *c* are the same.

(ii) Yield stage (d to e) Beyond the elastic limit load on the specimen increases with strain till the point *d* is reached. Beyond *d*, there is a sudden drop in load from *d* to *e*. *d* is known as upper yield point and *e* is denoted as lower yield point. Large deformation with no increase in load occurs in *ef* which is called plastic yielding.

(iii) Ductile stage (f to g) Beyond *f*, the material offers resistance to further straining up to the point *g* and *fg* is called ductile stage.

(iv) Plastic yielding stage (g to h) Specimen extends almost at constant load. From *g* to *h*, the deformation is called plastic yielding, *h* being ultimate load point where the load is the highest and corresponding stress is called ultimate stress.



**Fig. 3.10** Stress-strain curve for mild steel

(v) Load extension stage ( $hi$ ) Final stage  $hi$  occurs very rapidly. In this stage specimen extends under decreasing load. At the breaking point  $i$ , the neck forms and it breaks down into two pieces.

2. Properties of mild steel Following are the properties of mild steel.

1. It can be magnetised permanently.
2. It can be readily forged and welded.
3. It cannot be easily hardened and tempered.
4. It has fibrous structure.
5. It is malleable and ductile.
6. It is not easily attacked by salt water.
7. It is tougher and more elastic than wrought-iron.
8. It is used for all types of structural work.
9. It rusts easily and rapidly.
10. Its melting point is about  $1400^{\circ}\text{C}$ .
11. Its specific gravity is 7.80.
12. Its ultimate compressive strength is about 80–120 kN per  $\text{cm}^2$ .
13. Its ultimate tensile and shear strengths are about 60–80 kN per  $\text{cm}^2$ .
14. Chemical composition:
 

Sulphur	0.06%
Phosphorous	0.065 %
Carbon	up to 0.1%

3. Usage It is observed that steel is required for the existence of the heavy and light engineering industries, ship building, railways and rolling stock, automobiles, sheet metal industries, power generation and electrical industries, etc. It should also be noted that the entire range of electrical engineering industry depends upon the property of magnetism of steel.

#### (b) High yield strength deformed bars or Tor steel

1. Definition To increase the resistance to slipping between steel bars and the concrete, the surface of the bars is sometimes roughened. Such bars are known as deformed bars or ribbed tor steel or HYSD bars.
2. Manufacturing It is manufactured by controlled cold twisting of hot rolled deformed bars.
3. Chemical composition Carbon—0.3%; Sulphur—0.055%; Phosphorous—0.055%.
4. Grades Tor 40 with a yield strength of  $415 \text{ N/mm}^2$ ; Tor 50 with a yield strength of  $500 \text{ N/mm}^2$ .
5. Economy It is given in Table 3.5.

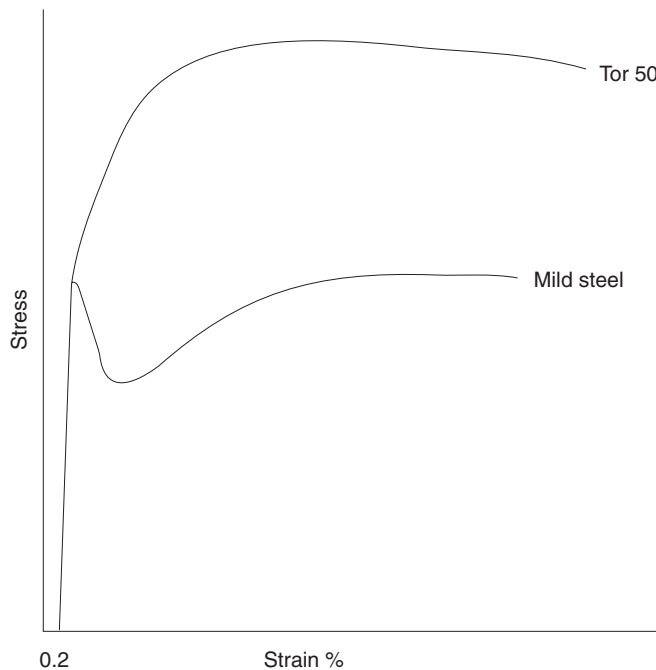
Table 3.5

	Mild steel	Tor steel	Per cent of saving in weight	Total saving
Tension	100%	60%	40%	33%
Compression	100%	70%	30%	
Shear distribution	100%	75%	25%	
Reinforcement	100%	80%	20%	

## 6. Properties

- (i) Tor steel is weldable.
- (ii) Ultimate strength is 55000 N/mm<sup>2</sup>.
- (iii) Elongation is 12 per cent.
- (iv) Stress–strain curve is shown in Fig. 3.11.

7. Usage Tor steel is a safe, efficient, economical reinforcement suitable for all types of RCC constructions such as buildings, roads, bridges, reservoirs, irrigation projects, hydroelectric, thermal and nuclear power projects, docks and harbours, marine structures, pile foundations, public health engineering works, precast concrete, etc.



**Fig. 3.11** Stress-strain curve for Tor steel and mild steel

### 8. Advantages

- (i) It has 65 per cent greater yield strength.
- (ii) It has 100 per cent greater bond strength.
- (iii) It has highest fatigue strength.
- (iv) It has high bendability.
- (v) It has satisfactory and easy weldability.
- (vi) It gives lesser crack width.
- (vii) It provides 20 per cent more factor of safety due to hyper resistance.
- (viii) It is suitable for both tension and compression reinforcement.
- (ix) It does not need end hooks.
- (x) Net economy is achieved in cost of reinforcing steel up to 40 per cent in tension and up to 30 per cent in compression.

## 3.8 WOOD

Timber is a form of wood suitable for building or engineering purposes. It is obtained from trees. All trees are divided into the following two groups based on their mode of growth.

- (i) *Endogenous trees* are those which grow by the formation of layers of new wood crossing and penetrating the fibres of the wood previously formed, e.g., bamboo, palmyrah, coconut, etc.
- (ii) *Exogenous trees* are those which grow outwards by the addition of rings of young wood, e.g., teak, sal, etc. The cross-section of these trees shows distinct concentric rings, called annual rings. Timbers obtained from the exogenous trees are mainly used in engineering works. Exogenous trees are again sub-divided into
  - (a) *Conifers* or evergreen trees which yield soft wood, e.g., pine, deodar, etc.
  - (b) *Deciduous* or broad-leaf trees which yield hard wood, e.g., teak, sal, etc.

Timbers used for engineering works are mostly derived from deciduous trees.

### 3.8.1 Characteristics of Soft Timber

- (i) Soft timber is light in weight.
- (ii) It is light in colour.
- (iii) It is resinous.
- (iv) It has straight fibres.
- (v) It has distinct annual rings.
- (vi) It is comparatively weak.
- (vii) It can be split easily.

### 3.8.2 Characteristics of Hard Timber

- (i) Hard timber is heavy in weight.
- (ii) It is dark in colour.
- (iii) It is non-resinous.
- (iv) It is close grained.
- (v) It does not show clear annual rings.
- (vi) It is strong.
- (viii) It is durable.

### 3.8.3 Structure of an Exogenous Tree

The cross-section of an exogenous tree is shown in Fig. 3.12.

*Pith* is the innermost, central portion of a tree. It consists of cellular tissues.

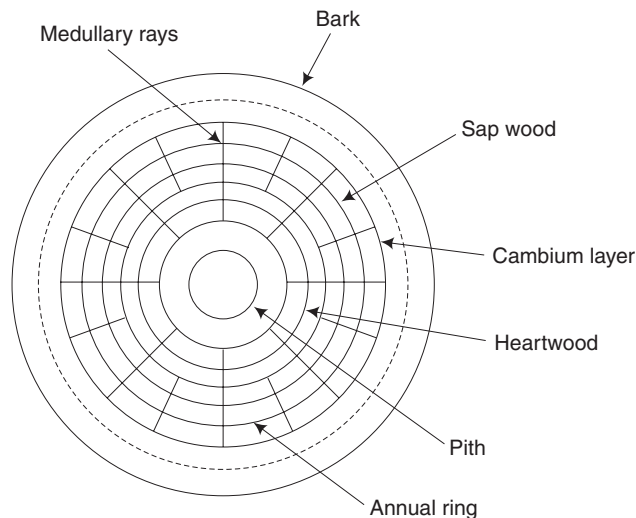
*Heartwood* is the inner annual rings surrounding the pith. Heartwood is darker in colour and is strong and durable. Heartwood is used for all engineering works.

*Sapwood* is the portion containing the outer annual rings between the cambium layer and the heartwood. It is light in colour as compared to heartwood. Sapwood cannot be used for any engineering work because it contains large amount of moisture and is liable to decay quickly.

*Cambium* layer is the soft ring surrounding the outermost ring of sapwood.

*Bark* is the outermost layer or skin of the trunk which covers the wood.

*Medullary rays* are the thin radial fibres extending from pith to cambium layer.



**Fig. 3.12** *Cross-section of wood*

### 3.8.4 Seasoning of Timber

The process of reducing the moisture from timber is known as seasoning. Freshly felled tree contains large amount of moisture. If the percentage of moisture is more than 20 per cent then different types of fungus and insects attack the wood. Hence timber needs seasoning. Following methods can be used for seasoning the timber.

1. *Natural Seasoning or Air Seasoning* In this method, sawn pieces of timber are stacked on stone or brick supports, a little above the ground in layers with sufficient space between them under a shed. They are left this way to get free circulation of air for a long period (two to four years). This is a slow method of seasoning but it is cheap and simple.

2. *Water Seasoning* In this method, the logs of wood are immersed in water, preferably in the running water of stream or river for two to four weeks. By doing so, sapwood is removed. The logs are then taken out and kept in open air to dry out. Such logs neither warp nor develop cracks but become brittle and their strength is also reduced.

3. *Boiling* In this method, the timber is either boiled in water or exposed to the action of water for about four hours. It is then taken out and slowly dried. Even though the period of seasoning is less, it is an expensive method.

4. *Electrical Seasoning* In this method, high frequency alternating current is passed through the timber. The timber gets heated and dries out. This method results in uniform seasoning of wood but the capital cost of equipment needed is more. This method is used in the manufacture of plywood.

5. *Chemical Seasoning* In this method, green timber is soaked in saturated salt solution, then removed and seasoned in the ordinary way. The interior moisture is drawn out by the saturated salt solution and the timber part dries before the outer one.

6. *Kiln Seasoning* In this method, the timber is stacked in a chamber or kiln. The chamber is artificially heated to 40° to 90°C by passing hot air in it for three to 12 days. The time and temperature required for seasoning depends on the type of the timber. This is one of the best artificial methods for seasoning wood. By using this method, moisture content in wood can be lowered to a large extent in a shorter period. This method also ensures the availability of well seasoned wood throughout the year.

### 3.8.5 Properties of Wood

Most important properties of wood may be discussed under the following general headings.

1. *Colour and Odour* Most trees are characterised with a typical colour and odour. A freshly cut teakwood has a golden yellow shade. The softwoods like deodar and pine show light (white) colours. As regards to odour (smell), quite a few woods are immediately identified by their characteristic smell. Teak wood has an aromatic smell.

2. *Specific Gravity* Wood is a very light material, its specific gravity being always less than one (that of water). Woods show good deal of variation in their specific gravity. Some

varieties may be as light as 0.3 whereas in other varieties of timber, the specific gravity may be up to 0.9. This depends on their structure and presence of pores in them.

3. *Moisture Content* All woods are hygroscopic in nature. They gain moisture from atmosphere. Wood may absorb moisture more than 2–2.5 times than its own weight. A moisture content of 12–15 per cent in air-seasoned woods is considered quite safe for timber being used in any construction.

4. *Grain* In a normal wood, the tracheids and vessels (collectively called as fibres) grow parallel to the length of the tree trunk. This type of structure is called a straight grain. The fibres may be very tightly and closely packed giving rise to a fibre grained texture in wood. In other cases, they may be broad and quite wider (comparatively). Such a structure is then termed as coarse grained. Sometimes the fibres do not grow essentially parallel to the trunk. These may grow in a twisted, spiral or interlocked manner. Such structure is called cross-grained.

5. *Shrinkage and Swelling* The newly cut wood loses moisture when made to dry naturally or artificially. On drying, the wood undergoes a shrinkage, Similarly, dry wood on getting rain soaked or wetted may undergo considerable swelling. Thick-walled cells shrink more than the thin walled cells. It is for this reason that the hardwoods shrink more than the softwoods.

6. *Strength* The most important fact about the strength of timber is that it is not the same in all the directions. The strength of wood is determined with reference to the direction of grain of the wood under load. Besides grain, many other factors also influence the strength of timber. These are

(a) **Density**—Higher the density of timber, greater will be its strength.

(b) **Moisture content**—Higher the moisture content, lower is the strength of timber.

(c) **Presence of defects**—There may be a number of natural and artificial defects in timber such as cross-grain, knots and shakes, etc. All of them cause a decrease in the strength of the timber.

### 3.8.6 Uses of Timber

- (i) It is used for door and window frames, shutters of doors and windows, roofing materials, etc.
- (ii) It is used for formwork of cement concrete, centering of an arch, scaffolding, etc.
- (iii) It is used for making furniture, agricultural instruments, sports goods, musical instruments, etc.
- (iv) It is used for making railway coach wagons.
- (v) It is used for making toys, engraving work, matches, etc.
- (vi) It is used for railway sleepers, packing cases, etc.
- (vii) It is used for temporary bridges and boat construction.

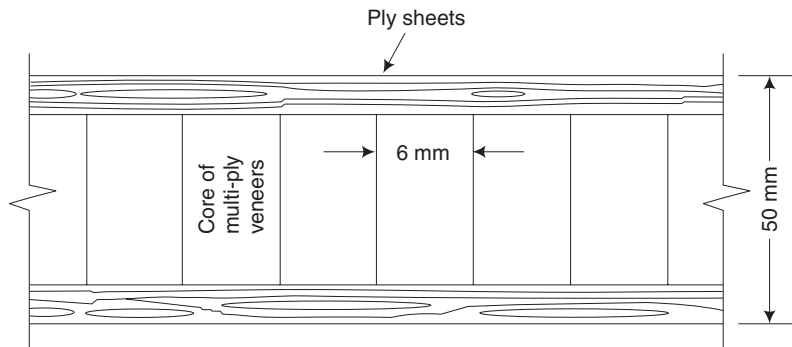
### 3.8.7 Plywood

The meaning of term *ply* is a thin layer. Plywoods are boards which are prepared from thin layers of wood or veneers. Three or more veneers in odd numbers are placed one above the other such that the direction of grains of successive layers are at right angles to each other. They are held in the desired position by application of suitable adhesives. The placing of veneers normal to each other increases the longitudinal and transverse strength of plywoods.

Plywoods are used for various purposes such as ceilings, doors, furniture partitions, panelling walls, packing cases, railway coaches, formwork for concrete, etc.

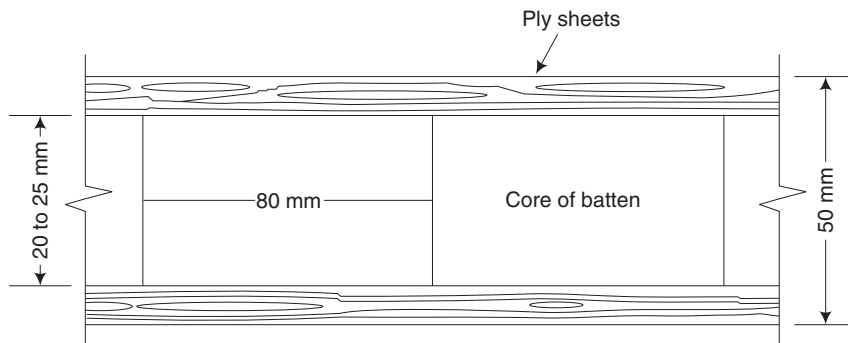
**Forms of Plywood** Plywoods are available in different commercial forms such as batten board, lamin board, metal faced plywood, multi-ply, three-ply, veneered plywood, etc.

**Batten Board** It is a solid block with core sawn thin wood as shown in Fig. 3.13. The thickness of core is about 20 mm to 25 mm and the total thickness of board is about 50 mm. These boards are light and strong. They do not crack or split easily.



**Fig. 3.13** *Batten board*

**Lamin Board** It is similar to batten board except that the core is made of multi-ply veneers as shown in Fig. 3.14. The thickness of each veneer does not exceed 6 mm and the total thickness of the board is about 50 mm.



**Fig. 3.14** *Lamin board*



In metal faced plywood, the core is covered by a thin sheet of aluminium, copper, bronze, steel, etc. This plywood is rigid and it is cleaned.

The plywoods made from more than three plies are designated as multi-ply. The number of veneers is odd. The thickness may vary from 6 mm to 25 mm or more.

The plywoods prepared from three plies only are known as three-ply. In veneered plywood, the facing veneer is of decorative appearance and it is used to develop an ornamental effect.

### **Advantages**

1. Plywoods are light in weight.
2. They are available in different sizes.
3. Plywoods do not split in an axial direction.
4. They possess uniform tensile strength in all directions.
5. They are not easily affected by moisture.

## **3.9 PLASTICS**

Plastics are organic substances which consist of resins in combination with a moulding compound. The synthetic resins may be phenol, vinyl, cellulose, etc. and the moulding compound may be fillers, plasticizers, solvents, pigments, hardeners, etc.

### **Advantages**

1. They have high resistance to corrosion.
2. They are light in weight and hard.
3. They are not affected by fungus, vermins and rot.
4. They can be used as thermal and electrical insulations.
5. They can be easily moulded.
6. They have good shock-absorbing capacity.
7. They have pleasing appearance.
8. They are cheap.

**Types of Plastics can be divided into two types.**

1. Thermoplastics
2. Thermo-setting plastics

### **3.9.1 Thermoplastics**

Plastics which become soft when heated and hard when cooled are called thermoplastics. The process of softening and hardening may be repeated for an indefinite time. It is possible to shape and reshape these plastics by means of heat and pressure. One important advantage of this variety of plastics is that the scrap obtained from old and worn out articles can be effectively used again.

The following are some of the important thermo plastics.

1. *Acrylic* Methylmethacrylate is an important constituent of this class of plastics. These are more transparent, rough and strong and do not shudder under impact. It is not affected by moisture and light acids. It is used in place of glass doors and windows and safety glass in automobile and aircrafts.
2. *Cellulose acetate* They are made from cotton seed and used as electric cables, hand rails, etc.
3. *Polythene* Transparent, chemically unaffected by moisture and temperature. Used for making pipes, covers for curing of cement and moisture proof packings.
4. *Perpex* Formed in the shape of sheets which do not break easily. Used as lamp shades, electric fittings and various other building usages.
5. *Poly vinyl chloride* It is a product obtained from vinyl chlorides and acetate. It resists attacks by acids and alkalis. It is light weight and withstands wear and tear. It is used as drainage pipes, floor-finish, emulsion paints, etc.

### 3.9.2 Thermo-setting Plastics

The thermo-setting plastics are the plastics which become rigid when moulded at suitable pressure and temperature. This type of plastic passes originally through thermo plastic stage. Thermo-setting plastics are strong, durable and hard. They are mainly used in engineering applications of plastics.

The commonly used thermo-setting plastics are phenol formaldehyde, phenol-furfuraldehyde and urea-formaldehyde plastics.

*Phenol formaldehyde* It is formed by heating phenol and benzene in the presence of suitable catalysts.

*Phenol-furfuraldehyde* It is formed by digesting husks of rice, oat, ground-nut with  $H_2SO_4$  distilling the mixture to separate the furfuraldehyde vapour and allowing the vapours to react with phenol in presence of catalysts.

*Urea-formaldehyde* Urea reacts with formaldehyde in presence of catalysts. These are used for making dishes, drinking glasses, plates, etc.

*Uses*

1. They are used for making plumbing fixtures, fittings and water storage tanks.
2. They are used for making floor and wall tiles.
3. They are used to produce pipes.
4. They are used to form flat sheets used for enclosure panels.
5. Foamed plastics are used for roofing.
6. They are used for doors and windows frames.
7. Plastics are used as an insulating material.

## 3.10 PROPERTIES OF BUILDING MATERIALS

### 3.10.1 Introduction

Building materials are found to be the basic elements for all engineering structures. So the behaviour of the structure depends on the behaviour of the basic elements, i.e. on the various characteristics and properties of the building material. Such properties may be classified into various categories as follows.

1. Physical properties
2. Mechanical properties
3. Chemical properties
4. Electrical properties
5. Magnetic properties
6. Optical properties
7. Thermal properties

From constructional aspects, the physical and mechanical properties are predominant. Hence it is essential for a civil engineer to have knowledge on the various physical and mechanical properties of building materials.

### 3.10.2 Physical Properties

Various physical properties of a building material are as follows.

- (i) Bulk density
- (ii) Chemical resistance
- (iii) Coefficient of softening
- (iv) Density
- (v) Density index
- (vi) Durability
- (vii) Porosity
- (viii) Specific heat
- (ix) Thermal conductivity
- (x) Thermal capacity
- (xi) Water absorption
- (xii) Permeability

(i) *Bulk Density* It is defined as the mass per unit volume of material in its natural state, i.e., including volume of pores and voids. Table 3.6 lists bulk densities of different building materials.

(ii) *Chemical Resistance* The ability of the material to resist against the action of acids, alkalis, gases and salt solution is known as its chemical resistance. Chemical resistance is carefully examined while selecting material for sewer pipes, hydraulic engineering installations, sanitary facilities, etc.

**Table 3.6** Bulk densities of common building materials

S.No.	Building materials	Bulk density in $\text{kN/m}^3$
1.	Clay brick	16 to 18
2.	Dense limestone	18 to 24
3.	Granite	25 to 27
4.	Gravel	14 to 17
5.	Heavy concrete	18 to 25
6.	Light concrete	5 to 18
7.	Sand	14.5 to 16.5
8.	Steel	78.5

(iii) *Coefficient of Softening* It is the ratio of compressive strength of material saturated with water to that in dry state. Materials having coefficient of softening more than or equal to 0.8 are referred to as the water-resisting materials.

(iv) *Density* It is defined as the mass per unit volume of the material in its homogeneous state, i.e. neglecting the volume of pores and voids.

(v) *Density Index* The ratio of bulk density of the material to its density is known as its density index. Thus, it denotes the degree to which its volume is filled up with solid matter. Density index for most of the building materials is less than unity.

(vi) *Durability* The property of a material to resist the combined action of atmospheric and other factors is known as its durability. The life and maintenance cost of any structure depends upon the durability of the materials which it is composed of.

(vii) *Porosity* The degree by which the volume of material is occupied by pores is termed as porosity. It is the ratio of volume of voids to the total volume of the specimen.

(viii) *Specific Heat* The term specific heat indicates the quantity of heat (expressed in kilocalories) required to heat one N of material by one degree centigrade.

(ix) *Thermal Conductivity* Thermal conductivity of a material is defined as the amount of heat in kilocalories, that will flow through a unit area of the material with unit thickness in unit time and when the difference of temperature on its faces is also unity. The reciprocal of thermal conductivity of a material is termed as its thermal resistivity.

(x) *Thermal Capacity* The property by which the material absorbs heat is termed as its thermal capacity. It is obtained by the following equation

$$T = H / (M \times (t_1 \sim t_2))$$

where

$T$  = thermal capacity in  $\text{J/N } ^\circ\text{C}$

$H$  = quantity of heat required to increase the temperature of a material from  $t_1$  to  $t_2$  in J

$M$  = mass of material in N

$t_1 \sim t_2$  = temperature difference of material before and after heating in  $^\circ\text{C}$

(xi) *Water Absorption* The ability of a material to absorb and retain water is termed as its water absorption. It is expressed either as percentage of weight or percentage of volume of dry material. It mainly depends on the bulk density and porosity of the material.

(xii) *Permeability* The capacity of a material to allow water to pass through it under pressure is referred as its permeability. It denotes the quantity of water that will pass through an unit cross-sectional area of the material in one hour at constant pressure.

### 3.10.3 Mechanical Properties

The various mechanical properties of building material are as follows.

- (i) Abrasion
- (ii) Elasticity
- (iii) Plasticity
- (iv) Strength
- (v) Impact strength
- (vi) Wear
- (vii) Fatigue
- (viii) Hardness
- (ix) Brittleness
- (x) Ductility
- (xi) Malleability
- (xii) Toughness

**(i) Abrasion** It is the property of a material by which it resists the action of moving load. It is found by dividing the difference in weights of the specimen, before and after abrasion with the area of abrasion.

**(ii) Elasticity** The property by which a material regains its original shape and position after the removal of external load is known as elasticity.

**(iii) Plasticity** It is the property of a material, by which no deformation vanishes, when it is relieved from the external load.

**(iv) Strength** The ability of a material to resist failure under the action of external load is known as its strength. The loads to which a material is commonly subjected to are compression, tension and bending. The corresponding strength is obtained by dividing the ultimate load with the cross-sectional area of the specimen.

**(v) Impact strength** It is defined as the quantity of work required to cause failure per unit of its volume. Thus, the impact strength indicates the toughness of the material.

**(vi) Wear** The failure of a material under the combined actions of abrasion and impact is known as its wear. It is usually expressed as a percentage of loss in weight and it is very important to decide the suitability of a material for use of road surfaces, railway ballast, etc.

**(vii) Fatigue** When the materials are subjected to repetitive fluctuating stress, they will fail at a stress much lower than that required to cause fracture under steady loads. This property is known as fatigue.

**(viii) Hardness** It is the ability of a material to resist penetration by a harder body. It plays an important role in deciding the workability and use of a material for floors and road surfaces. For stone materials, hardness can be determined with the help of Mohr's scale of hardness. It is a list of ten materials arranged in the order of increasing hardness as shown in Table 3.7. The level of hardness of a material lies between the hardnesses of two materials, i.e. the one which scratches and the other which is scratched by the material to be tested.

**(ix) Brittleness** A material is said to be brittle when it cannot be drawn into a wire by tension. A brittle material fails suddenly under pressure without appreciable deformation preceding the failure. Concrete, glass, cast-iron, rock materials, etc. are some of the examples of brittle materials.

**(x) Ductility** It is a property of a material by which it can be drawn into a wire by tension.

**(xi) Malleability** The property by which a material can be uniformly extended in a direction without rupture is known as malleability. This property finds its applications in many operations such as forging, hot rolling, etc.

**(xii) Toughness** Toughness is the property of a material that enables it to absorb energy without fracture. This property is useful in shock loading.

**Table 3.7**

<i>S.No.</i>	<i>Material</i>	<i>Remarks</i>
1.	Talcum	Readily scratched by finger nail
2.	Rock-salt or gypsum	Scratched by finger nail
3.	Calcite	Readily scratched by a steel knife
4.	Fluorite	Scratched by a slightly pressed steel knife
5.	Apatite	Scratched by a heavily pressed steel knife
6.	Feldspar	Slightly scratches glass and is not scratched by a steel knife
7.	Quartz	Readily scratches glass and is not scratched by steel knife
8.	Topaz	Readily scratches glass and is not scratched by steel knife
9.	Corundum	Readily scratches glass and is not scratched by steel knife
10.	Diamond	Readily scratches glass and is not scratched by steel knife

### *Short-Answer Questions*

1. Give examples for igneous, sedimentary and metamorphic rocks.
2. How are igneous rocks formed?

3. What are the major operations involved in the manufacture of bricks?
4. What are the dimensions of a standard brick?
5. What are the raw materials used in manufacture of cement?
6. Why gypsum is added during the manufacture of cement?
7. What is meant by hydration of cement?
8. What is the need for reinforcement in RCC?
9. Draw stress–strain diagram for mild steel.
10. What is meant by M15 concrete?
11. How are bricks classified?
12. How are rocks classified based on its formation?
13. What do you mean by reinforced concrete? What is the necessity of reinforcing the concrete?
14. What is expanded metal and where it is used?
15. What are the uses of channel and T-sections?
16. What are the main functions of a civil engineer?
17. What are the objectives of surveying?
18. What are the constituents of a brick.
19. List various types of cement.
20. What are the advantages of reinforced cement concrete?
21. What are the types of light weight concrete and polymer concrete?
22. What is the main disadvantage of normal concrete?
23. What are the several ways in which aerated concrete is manufactured?
24. What do you mean by no-fine concrete?
25. What is high density concrete and where is it mainly used?
26. List the monomers normally used in polymer concrete.
27. What are the applications of PIC?
28. What is meant by FRC?
29. What are the functions of fibres in FRC? State the different types of fibres.
30. Define workability.
31. Define compressive strength of concrete.
32. What are the functions of admixtures?
33. What do you understand by non destructive testing of concrete?
34. List out the test methods normally available for non-destructive testing of concrete.
35. What is the main advantage of using tor steel?
36. Draw the stress–strain curve for tor steel.

37. Write down the chemical composition of tor steel. What are the grades of tor steel?
38. What are endogenous and exogenous trees?
39. Draw the cross-section of an exogenous tree.
40. Define the following terms.
  - (i) Pith
  - (ii) Cambium
  - (iii) Bark
  - (iv) Medullary rays
  - (v) Heartwood
  - (vi) Sapwood
41. What is seasoning of timber?
42. What are the uses of timber?
43. What are plywoods?
44. Define plastics. What are the different types of plastics?
45. Give examples for thermo plastics and thermo-setting plastics.
46. Define hardness.
47. Define fatigue and ductility.
48. Define porosity.
49. Define water absorption.
50. Define thermal conductivity.
51. Define mortar
52. What is gauged mortar?
53. What is the type of mortar used for plastering and pointing works?
54. Why steel is considered as a good reinforcing material?
55. What are the various forms of reinforcing steel?

### *Exercises*

1. List the uses of the following construction materials: bricks, stones, cement, cement concrete and steel.
2. What are the qualities of a good brick?
3. What are the requirements for a stone which is to be used as a building material?
4. Explain the properties of cement.
5. Which are the normal steel sections available in the market? Give neat sketches.
6. Explain in detail, the functions of a civil engineer.
7. Explain the constituents of brick.
8. Describe the various types of cement, specifying the applications for each.



9. Briefly explain the different types of light weight concrete and list out its advantages.
10. Write short notes on the following types of concrete.
  - (i) High-density concrete
  - (ii) Polymer concrete
  - (iii) Fibre reinforced concrete
11. Describe briefly the factors affecting workability.
12. Explain, how you will measure the workability of the concrete mixture.
13. Briefly explain about the testing of hardened concrete.
14. Explain the various factors affecting the compressive strength of concrete.
15. Explain the methods of testing the tensile strength of concrete with a neat sketch.



**UNIT-3**

**BUILDING COMPONENTS AND  
STRUCTURES**



# Chapter 4

## FOUNDATION

### 4.1 SELECTION OF SITE

With the knowledge of the properties and uses of various construction materials, the next step is to study about the actual construction procedure. The first and foremost job in construction is to select a suitable site for the building. A properly selected site of the building gives enhanced beauty to the building without any extra expenditure.

The following points should be considered while selecting the site for any particular building:

1. Soil at the building site should not be of artificially made-up type. Buildings constructed over such soils normally undergo differential settlement and cracks are quite common in such buildings.
2. The site should not be undulating since this leads to increase in cost for levelling the ground.
3. The site should have its general slope, sloping away from the site in order to enable easy drainage of the building.
4. Civic services, such as main water supply mains, electric lines, telephone lines, drainage sewers, should be near the site so that no additional costs are incurred.
5. The groundwater table in the site should not be high.
6. Type of the building also affects the site selection. For example, industrial buildings should be situated outside the city, residential buildings must be near schools and hospitals, and public buildings should be located in open areas so that all the requirements may be fulfilled.
7. The selected site should be as far as possible large enough to provide sufficient light and air to the building.
8. The building site should not be in a depression since this will cause drainage problems as well as affect the aesthetic appearance.
9. If the site is sloping, it should be rising towards the back. This improves the elevation and also gives the feeling of comfort. On sloping sites, planning with

differential floors becomes possible. The garage and the miscellaneous utilities can be accommodated in the basement.

10. The site should be connected with good communication lines such as good system of roads and railways.
11. The site should possess good soil at reasonable depths so that the foundation cost is reduced.
12. The selected site should be adequate to accommodate all the essential accessories required in the building.
13. Residential buildings should not be located near workshops and factories since such locations are subjected to continuous noise.
14. A site along seashore is good from the entertainment point of view but sea breeze being damp affects health. Metallic fittings are liable to corrode here.
15. The topographical features of the site with natural and artificial surroundings affect the selection of site to great extent. For instance, in a region of the city having large buildings, a small residential building may not be aesthetically appealing.
16. For industrial buildings, the site selected should be such that
  - (a) all the raw materials required for the industry must be available nearby
  - (b) the labourers should be available from the nearby areas
  - (c) the site must have enough space for future expansion, of industry, for the construction of residential areas for workers, etc.
  - (d) suitable disposal plant to treat the solid or liquid wastes produced by the industry must be available at reasonable distance
17. Climate plays an important role in selecting sites for industrial buildings. For example, a cool and moist weather is more favourable for weaving and textile mills.

## 4.2 SUBSTRUCTURE

[Nov, Dec 2014; Apr, May 2015, Regulation 2008]

A structure essentially consists of two parts, namely, the *super structure* which is above the plinth level and the *substructure* which is below the plinth level. Substructure is otherwise known as the foundation and this forms the base for any structure. Generally, about 30 per cent of the total construction cost is spent on the foundation. The soil on which the foundation rests is called the *foundation soil*.

## 4.3 OBJECTIVES OF A FOUNDATION

[Nov, Dec 2011, 2012]

A foundation is provided for the following purposes:

1. To distribute the total load coming on the structure on a larger area
2. To support the structures
3. To give enough stability to the structures against various disturbing forces, such as wind and rain

4. To prepare a level surface for concreting and masonry work

#### 4.4 SITE INSPECTION

The general inspection of the site serves as a good guide for determining the type of foundation to be adopted for the proposed work. Hence, it is desirable to visit the site of work and inspect the same carefully. The inspection of the site helps in getting the data with respect to the following items:

1. Behaviour of ground due to variations in the depth of water table
2. Disposal of storm water at the site
3. Nature of soil by means of visual examination
4. Movement of ground due to earthquake, landslide, etc.

In order to know the quality and thickness of underground soil, test pits are made up to the foundation level, the soil is excavated and examined. Electrical methods are also adopted to determine the soil quality from the resistance offered by the soil for the passage of current.

#### 4.5 SOILS

##### 4.5.1 General

Soil is a complex material produced by the weathering of solid rock. It is the unaggregated or uncemented deposits of mineral and/or organic particles or fragments covering a large portion of the earth's crust.

For engineering purposes, soil is defined as a natural aggregate of mineral grains, that have the capacity of being separated by means of simple mechanical processes, e.g., by agitation in water. Soil Engineering, Soil Mechanics or Geotechnique is one of the youngest disciplines of civil engineering involving the study of soil, its behaviour and application as an engineering material.

##### 4.5.2 Types of Soils

The various types of soils are as follows:

1. Gravel
2. Sand
3. Silt
4. Clay

**1. Gravel** Soil particles of which more than 50 per cent have a size larger than 4.75 mm are called gravel. It is cohesionless and consists of unaltered mineral grains, which are angular to well-rounded in shape. Gravel is a very good foundation soil.

**2. Sand** It consists of cohesionless particles, of which more than 50 per cent have a size smaller than 4.75 mm. Sand particles are mostly unaltered mineral grains. Sand is also a good foundation soil.

**3. Silt** Silt comprises fine particles of weathered rocks with little or no plasticity. The presence of flake-shaped particles and/or organic and vegetable matters makes the silt-plastic. Organic silts are highly compressible and they have a light grey to dark grey colour. Silt is not quite suitable for building foundation.

**4. Clay** It is composed of microscopic and sub-microscopic particles of weathered rock. Clay becomes plastic in the presence of water. Plastic clay has very low permeability. Clay is not a good foundation soil at places where water is likely to come in contact with the soil.

### 4.5.3 Soil Classification

The purpose of soil classification is to arrange various types of soils into groups according to their various engineering properties. For civil engineering purposes, soils may be classified by the following systems:

1. Particle size classification
2. IS classification system and unified soil classification
3. Textural classification

**1. Particle size classification** In this system, soils are classified according to the grain size. To indicate grain sizes, terms such as boulder, cobble, gravel, sand, silt and clay are used. The grain size of the various types of soils is given in Table 4.1.

**2. IS classification system and unified soil classification** This system is based on both grain size and plasticity properties of the soil and is therefore applicable to any engineering use. In this system of classification, soils are broadly divided into the following three categories.

- (i) Coarse-grained soils
- (ii) Fine-grained soils
- (iii) Highly organic soils

**Table 4.1** Grain size of various types of soils

S.No.	Soil	Grain-size
1.	Boulder	Greater than 300 mm
2.	Cobble	80 mm–300 mm
3.	Gravel	4.75 mm–80 mm
	1. Fine gravel	4.75 mm–20 mm
	2. Coarse gravel	20 mm–80 mm
4.	Sand	0.075 mm–4.75 mm
	1. Fine sand	0.075 mm–0.425 mm
	2. Medium sand	0.425 mm–2.0 mm
	3. Coarse sand	2.0 mm– 4.75 mm
5.	Silt	0.002 mm–0.075 mm
6.	Clay	Less than 0.002 mm



**(i) Coarse-grained soils** In these soils, more than half the total material by mass is larger than 0.075 mm IS sieve size. They are further divided into the following two subdivisions.

- (a) Gravel
- (b) Sand

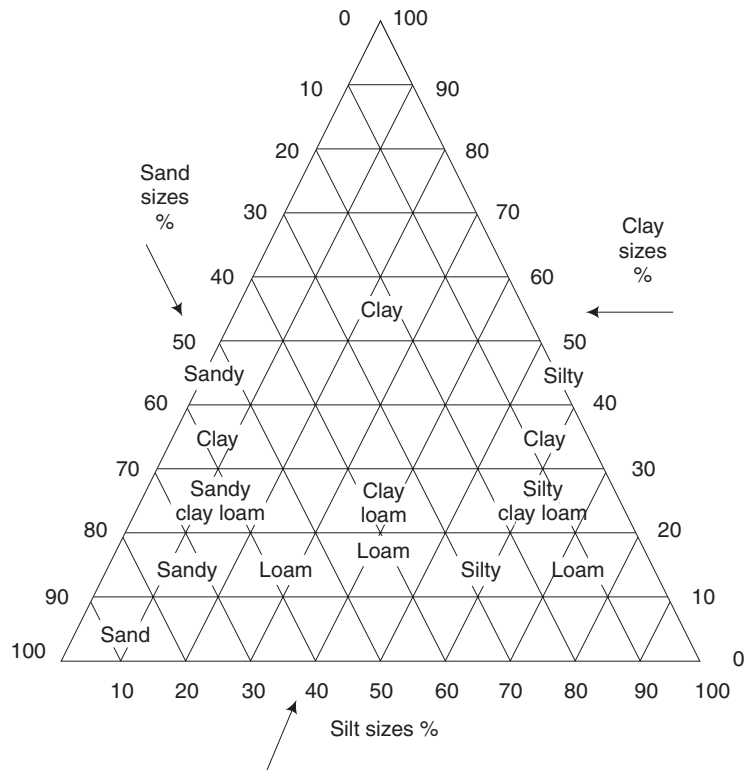
**(ii) Fine-grained soils** In these soils, more than half the material by mass is smaller than 0.075 mm IS sieve size. They are further divided into the following three subdivisions.

- (a) Inorganic silts and very fine sands
- (b) Inorganic clays
- (c) Organic silts and clays and organic matter

**(iii) Highly organic soils** These soils contain large percentages of fibrous organic matter, such as peat and the particles of decomposed vegetation. In addition, certain soils containing shells, concretions, cinders and other non-soil materials in sufficient quantities are also grouped in this division.

**3. Textural classification** Classification of composite soils based on the particle size distribution is known as textural classification. This classification is based on the percentages of sand, silt and clay sizes making up the soil. Such a classification is more suitable to describe coarse-grained soils rather than clay soils whose properties are less dependent on the particle size distribution. Probably the best known of these textural classifications is the triangular classification of US Public Roads Administrations shown in Fig. 4.1.

In the figure for the given percentages of the three constituents forming a type of soil, lines are drawn parallel to the three sides of the equilateral triangle, as shown by arrows in the chart. For example, if a soil is composed of 20 per cent sand, 20 per cent silt and 60 per cent clay, the three lines drawn accordingly intersect in the zone marked for clay. Hence, such a soil will be termed clay.



**Fig. 4.1** Textural classification

#### 4.5.4 Bearing Capacity of Soil [May, June 2009, 2010, 2011; Nov, Dec 2009, 2012]

This term is used to indicate the maximum load per unit area which the soil will resist safely without displacement. By dividing the ultimate bearing power of soil by a factor of safety, the safe bearing capacity is obtained.

On completion of a structure, there may be some displacement in the position of the foundation. For ordinary framed structures of concrete, the permissible angular distortion is  $1/500$  and the desirable value is  $1/1000$ . The maximum differential settlement should not exceed 25 mm in case of foundations on sandy soil and 40 mm in case of foundations on clayey soil.

In case of non-cohesive soils, such as sand and gravel, the allowable bearing capacity should be reduced by 50 per cent, provided that the water table is above or near the bearing surface of the soil. The bearing capacity of reclaimed soils or shrinkable soils can be taken as  $50 \text{ kN/m}^2$  in the absence of the site data.

The bearing capacity of the soil can be found by loading the soil, noting the settlement and by dividing the maximum load by the area on which the load is applied. The maximum load is obtained from the graph between the load and settlement.

#### 4.5.5 Methods of Improving Bearing Capacity of Soils [May, June 2009; Nov, Dec 2012]

In some cases, the bearing capacity of soil is so low that the dimensions of the footings, work out to be very large and uneconomical. Under such situations, it becomes necessary to improve the bearing capacity of the soils, which can be done by the following methods.

- (i) Increasing the depth of foundation
- (ii) Compacting the soil. This can be done by using the following methods.
  - (a) Running moist soil
  - (b) Rubble compaction into the soil
  - (c) Flooding the soil
  - (d) Vibrating the soil
  - (e) Vibroflotation method
  - (f) Compaction by pre-loading
  - (g) Using sand piles
- (iii) Draining the subsoil water
- (iv) Confining the soil mass
- (v) Grouting with cement
- (vi) Chemical treatments like injecting silicates, etc.

### 4.6 LOADS ON FOUNDATIONS

The type of foundation to be used depends upon the loads borne by it. There are three types of loads borne by the foundation—dead load, live load and wind load.

### 4.6.1 Dead Load

This is the self-weight of the various components of a building. The provision for the future construction must also be made in the dead-load calculation. In order to calculate the dead load, a knowledge of weight of the common building materials is necessary.

### 4.6.2 Live Load

This is also known as superimposed load and is the moveable load on the floor. This includes the weight of persons standing on a floor, weight of materials stored temporarily on a floor, weight of snow, etc.

### 4.6.3 Wind Load

In case of tall buildings, the effect due to wind should be considered. The exposed sides and roofs of such buildings are subjected to wind pressure and its effect is to reduce the pressure on the foundation in the windward side and to increase the pressure in the leeward side.

## 4.7 ESSENTIAL REQUIREMENTS OF A GOOD FOUNDATION

[May, June 2009, 2012; Apr, May 2015]

The following are the essential requirements of a good foundation:

1. The foundation should be so located that it is able to resist any unexpected future influence which may adversely affect its performance.
2. The foundation should be stable or safe against any possible failure.
3. The foundation should not settle or deflect to such an extent that will impair its usefulness.

## 4.8 TYPES OF FOUNDATION

[Nov, Dec 2009; May, June 2010; Apr, May 2015]

Foundation may be broadly classified into the following two categories.

1. Shallow foundation
2. Deep foundation

A *shallow foundation* is one in which the depth is equal to or less than its width. When the depth is more than the width, it is termed as a *deep foundation*.

### 4.8.1 Shallow Foundation

[May, June 2010, 2011, 2012; Nov, Dec 2010, 2014;  
Apr, May 2015, Regulation 2008]

When the depth of the foundation is less than or equal to its width, it is defined as a shallow foundation. The two main types of shallow foundation discussed in this section are the isolated footing and the combined footing.

The various types of shallow foundations are

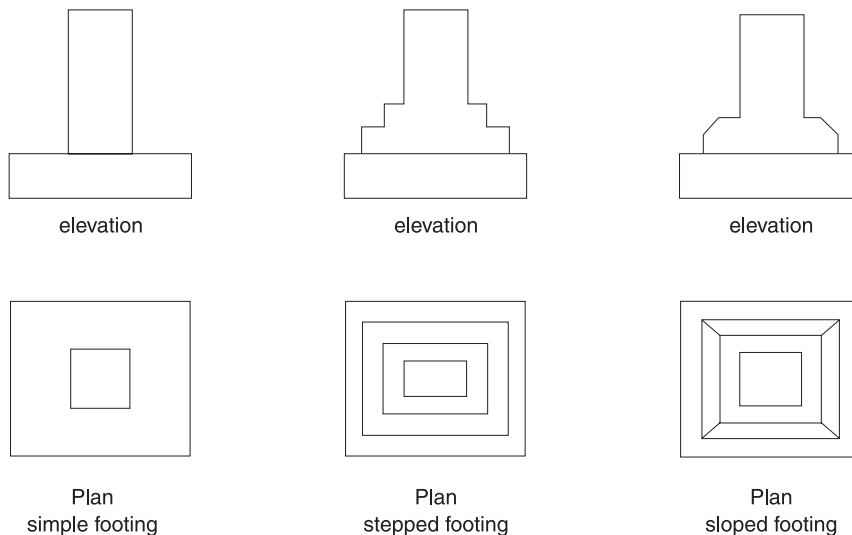
- Isolated column footing
- Wall footing
- Combined footing

- Cantilever footing
- Continuous footing
- Inverted arch footing
- Grillage foundation
- Raft or Mat foundation
- Stepped Foundation

### 1. Isolated Footing

[May, June 2012]

In framed structures where several columns are to be constructed, isolated footings can be adopted. The columns involved can be provided with masonry or concrete footing. If masonry footing is provided, steps are given and the foundation area is thus increased so that the stresses developed at the base are within the limit. Concrete can be moulded to any shape and hence a concrete footing may be a sloping one to provide sufficient spread. In case of masonry footing, the projection of each step must be  $1/2$  brick thick and each step is made of 1 or 2 bricks put together. Masonry footing and RCC footing are shown in Fig. 4.2. Isolated footing is provided under a column to transfer the load safely to the soil bed. If the column is loaded lightly, a spread is given under the base of the column. This spread is known as footing. For heavily loaded column, the total width of the footing may be very high. This is attained in three or four steps and is called *stepped footing*. If the total width of the footing is attained by gradually increasing the width towards the bottom, then it is called *sloped footing*.

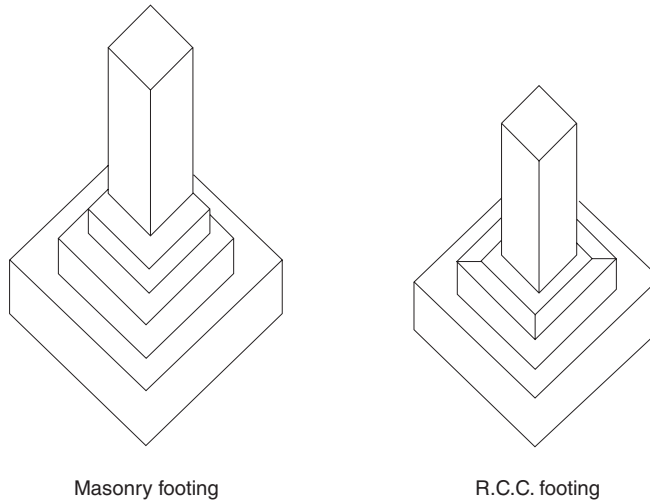


**Fig. 4.2** *Isolated or Column footing*

### 2. Wall Footing

[May, June 2012]

If the footing is provided throughout the length of the wall in the case of load-bearing walls, then it is called wall footing. Wall footings can be either simple or stepped.



**Fig. 4.3** Textural classification

**Depth of footing** The minimum depth of footing is given by the Rankine's formula as,

$$D = P/W \left( \frac{1 - \sin \phi^2}{1 + \sin \phi} \right)$$

where,

$D$  = minimum depth of footing

$P$  = safe bearing capacity of soil in  $\text{kg}/\text{m}^2$

$W$  = unit weight of soil in  $\text{kg}/\text{m}^3$

$\phi$  = angle of repose of soil in degrees

The minimum depth of footing for the load bearing wall is limited to 90 cm for the stability.

**Width of footing** It is obtained by dividing the load including dead load, live load and wind load etc. by the allowable bearing capacity of the soil.

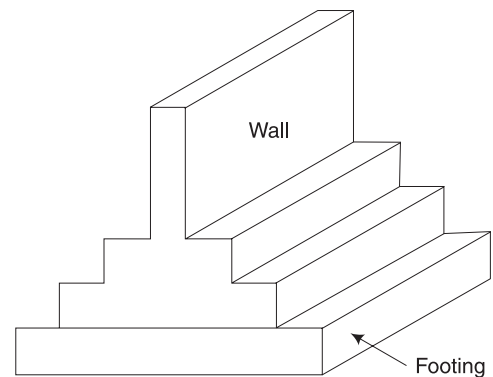
$$B = T/P$$

where,

$B$  = Width of footing in metre

$T$  = Total load per metre run in kg

$P$  = Safe bearing capacity of the soil in  $\text{kg}/\text{m}^2$

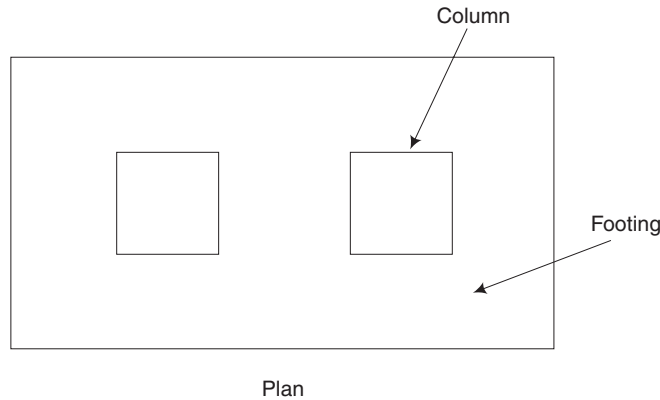


**Fig. 4.4** Wall footing

### 3. Combined Footing

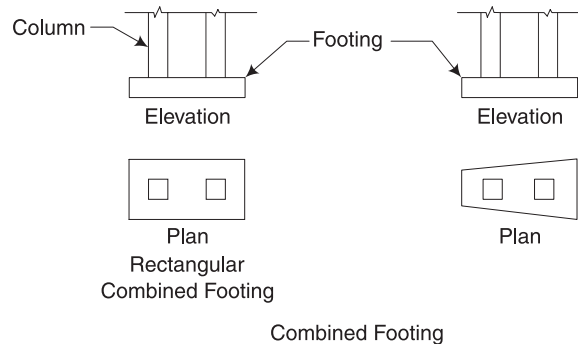
This type of footing is adopted when the space between two columns is so small that the foundation for individual columns will overlap. Combined footings are proportioned in such a way that the centre of gravity of the loads coincides with the centre of gravity of

the foundation. Hence these footings have either a trapezoidal or a rectangular shape. The plan of a combined footing is shown in Fig. 4.5.



**Fig. 4.5** *Combined footing*

If a footing is constructed for two or more columns, it is called combined footing. The shape of the combined footing is proportional in such a way that the centre of gravity of the resultant area is in the same vertical line as the centre of gravity of the loads. Generally, the shape of the footing is rectangular or trapezoidal as shown in Fig. 4.6.



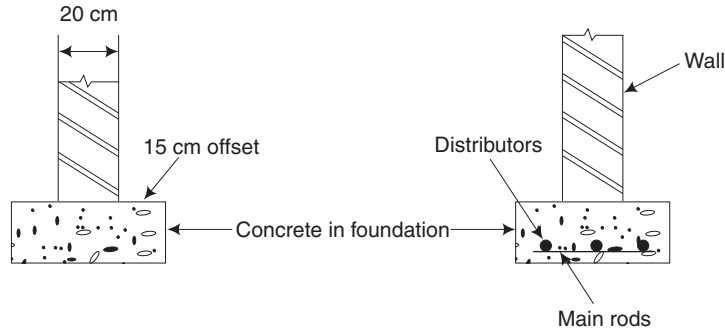
**Fig. 4.6** *Combined footing*

#### 4. Strip Footing

Strip footing is one of the different types of shallow foundation. This is used where soil of good bearing capacity is available at a depth of less than 3 m from the ground level. Since the footing is provided throughout the length of the wall in case of load bearing walls, it is also called as wall footing. Strip footings are classified as follows:

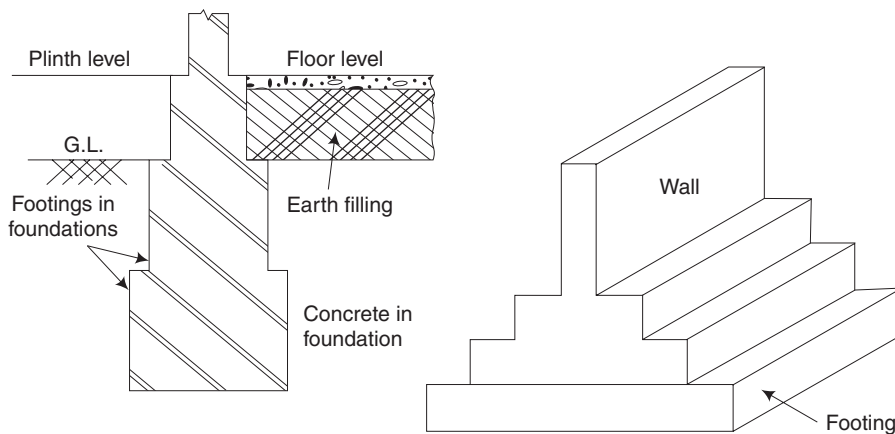
**1. Simple footing** Simple footings are provided in case of walls of very light structures like residential buildings. In simple footing, cement or lime concrete is used in foundation.

The projection beyond the face of the wall (offset) of the concrete base is 15 cm on either side as shown in Fig. 4.7.



**Fig. 4.7** Simple footing

**2. Stepped footing** Stepped footings are provided where the ground has a slope. Otherwise it becomes uneconomical to provide foundations at the same level. It consists of two or more footings of brick or stone masonry and a concrete bed below the ground level as shown in Fig. 4.8. The overlap between two layers of foundation concrete slab is equal to the depth of concrete slab or two times the height of the step, whichever is more. The depth of concrete bed is generally kept in even number of masonry courses. **[May, June 2014]**



**Fig. 4.8** Stepped footing

**Width of footing** It is obtained by dividing the total load including dead loads, live loads and wind loads, etc., by the allowable bearing capacity of the soil.

$$\text{Width of footing} = \frac{\text{Total load per metre run in } N}{\text{Safe bearing capacity of the soil in } N/m^2}$$

**3. Depth of footing** The minimum depth of the footing is given by the Rankine's formula as given below.

$$D = \frac{P}{W} \left( \frac{1 - \sin \phi}{1 + \sin \phi} \right)^2$$

where

$D$  = Minimum depth of footing

$P$  = Safe bearing capacity of the soil

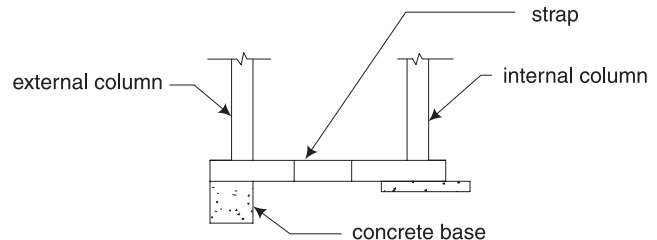
$W$  = Unit weight of the soil in  $\text{N/m}^3$

$\phi$  = Angle of repose of the soil in degrees

The minimum depth of footing for the load bearing wall is limited to 900 mm for the stability criteria. [May, June 2011]

### 5. Cantilever Footing

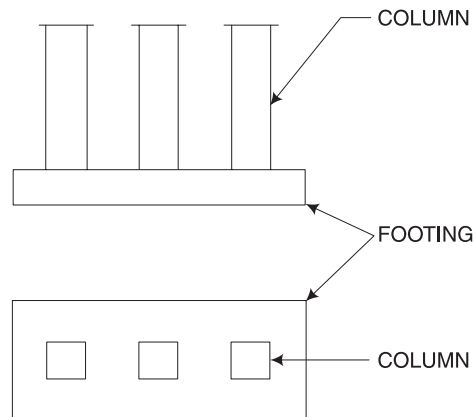
Cantilever footing consists of an eccentric footing for the exterior column and a concentric footing for the interior column and they are connected by a strap or a cantilever beam. Such footings are used when it is not possible to place a footing directly below a column because of limitations of boundary or eccentric loading conditions. The load from the exterior column is balanced by a load of the interior column acting about a fulcrum.



**Fig. 4.9** *Cantilever footing*

### 6. Continuous Footing

In this type of footing, a single continuous RC slab is provided as foundation for three or more columns in a row. This type of footing is more suitable to prevent the differential settlement in the structure and for the safety against earthquake.



**Fig. 4.10** *Continuous footing*

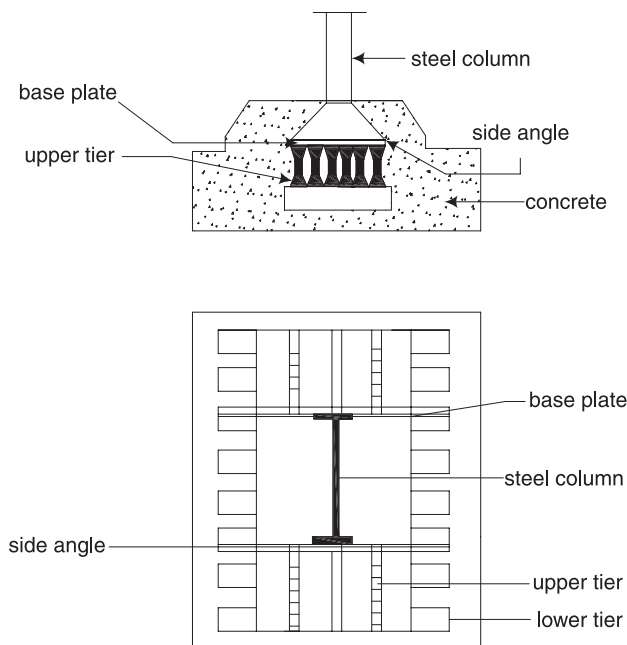


### 7. Inverted Arch Footing

In this type of footing, inverted arches are constructed between two walls at the base. It is suitable for soils of low bearing capacity and when the depth of the foundation is to be kept less. The end columns must be strong enough to resist the outward pressure caused by such action. This type of foundation is suitable for bridges, sensors, tanks, etc.

### 8. Grillage Foundations

Grillage foundation is used to transfer the heavy structural loads from steel columns to a soil having low bearing capacity. It is constructed by rolled steel joists (RSJ) which are placed in single or double tier. In double-tier grillage, the top tier is placed at right angles to the bottom tier. The distance between the flanges of RSJ should be equal to 1.5 to 2.0 times the width of the flange or 30 cm whichever is smaller. The steel joists of the grillage are kept in position by pipe separators and nuts. The whole arrangement of the rolled steel joists is completely embedded in concrete. The concrete filling is not supposed to take any load but it keeps the steel joists in position and prevents them from corrosion. The bed of concrete should have a minimum depth of 15 cm. A grillage foundation may be constructed for a single column or for more than one column.



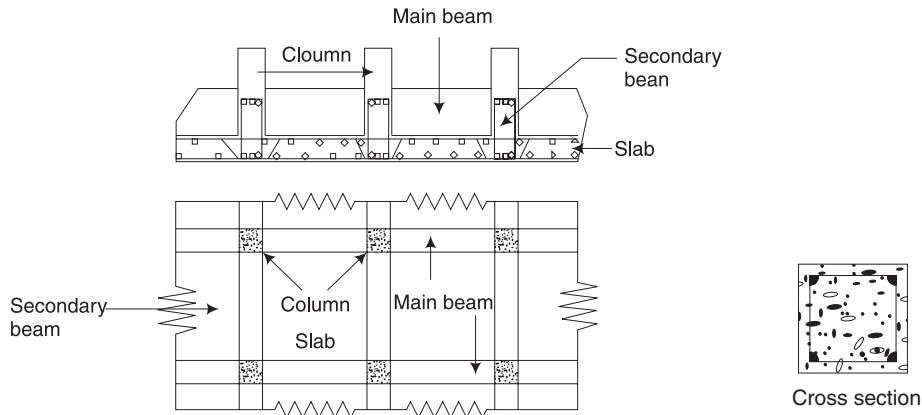
**Fig. 4.11** Grillage foundation

### 9. Raft Foundation or Mat Foundation

[Nov, Dec 2011]

When the load of the structure is very heavy and the bearing capacity of the soil is very low then raft foundation is adopted. In this type of foundation, the load is transmitted to the soil by means of a continuous slab that covers the entire area of the bottom of a structure similar to a floor. Due to low bearing capacity, large isolated footings are

necessary to support the structure. If the sum of the base areas of the footings required to support a structure exceeds about half the total building area then it is preferable to combine the footings into a single raft. In such case, raft foundation exerts the minimum contact pressure and also counteracts the effect of hydrostatic uplift.



**Fig. 4.12** Raft foundation

## 10. Deep Foundation

[Nov, Dec 2012]

Deep foundation consists of pile and pier foundations. Pier foundations are rarely used for buildings. This consists in carrying down through the soil a huge masonry cylinder which may be supported on solid rock.

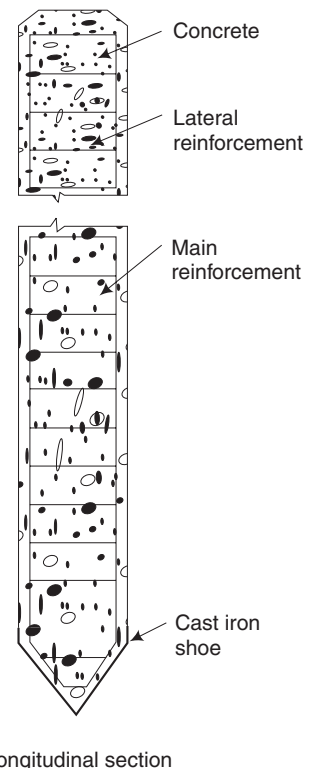
### 4.8.2 Different Types of Foundations

[May, June 2010; Nov, Dec 2010, 2012]

**1. Pile foundation** Pile is an element of construction used as foundation. It may be driven in the ground vertically or with some inclination to transfer the load safely. Loads are supported in two ways, i.e., either by the effect of friction between the soil and the pile skin or by resting the pile on a very hard stratum. The former is called friction the pile and the latter one is the load bearing pile.

Friction piles may be made of cast iron, cement, concrete, timber, steel, wrought iron and composite materials. Load bearing piles are steel sheet piles, concrete piles and timber piles. Piles may be cast-in-situ or precast. They may be cased or uncased.

**2. Under-reamed piles** Structures built on expansive soils often crack due to the differential movement caused by



**Fig. 4.13** Under-reamed pile

the alternate swelling and shrinking of soil. Under-reamed piles provide a satisfactory solution to the above problem. Figure 4.13 shows the details of an under-reamed pile.

The principle of this type of foundation is to transfer the load to a hard strata which has sufficient bearing capacity to take the load.

Single and double under-reamed piles may also be provided for foundations- of structures in poor soils overlying firm soil strata. In such soils if double under-reamed piles are provided, both the under-reams shall rest within the firm soil strata.

**3. Timber pile** In this type, trunks of trees are used as piles. The wood should be free from any defect. These piles may be circular or square. The dimension varies from 30 cm to 50 cm. The length of a timber pile should not exceed 20 times its top width to avoid bulking. At the bottom of the pile, an iron shoe is provided and at the top a steel plate is fixed.

**4. Composite piles** These piles are made up of two portions of different materials driven one above the other.

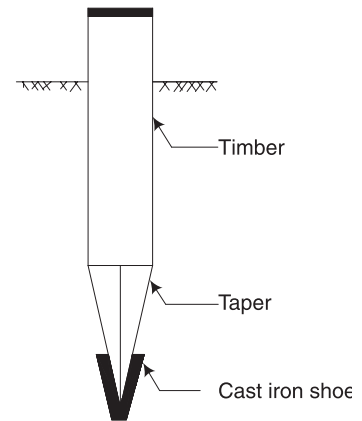
Common types of composite piles in use are

1. Timber and concrete
2. Steel and concrete

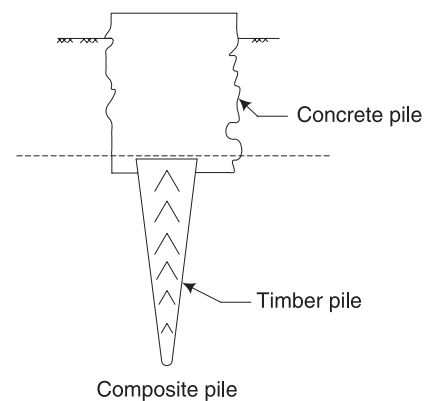
In the timber and concrete composite pile, the timber portion is used below the lowest level of the ground water table, and the concrete piles, usually cast-in-situ, is formed above it. This combination gives the twin advantage of durability of concrete piles and the cheapness of timber piles. In steel and concrete composite piles a steel piles, or H pile is attached to the lower end of concrete pile.

**5. Steel pile** Steel piles are made in three forms: rolled steel H-section piles, box piles and tube piles. There can be no restriction on length due to high strength. However, steel piles may be affected by corrosive agents like salt, moisture, acid or oxygen. To prevent the steel pile from corrosion, its thickness may be increased or encased in concrete or chemical coating with paint is applied.

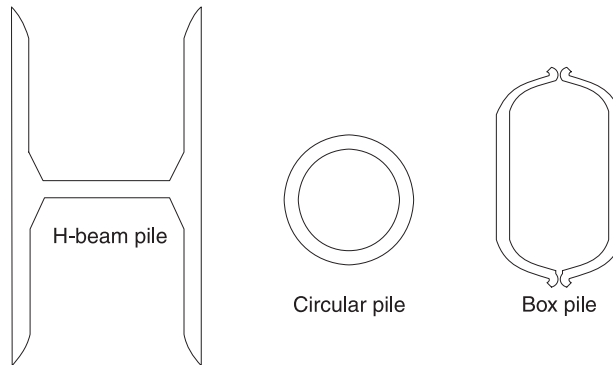
See Fig. 4.16. In this, H-Section pile having wide flanges is used. The pile projects slightly above the ground level and foundations as a column. Due to its small cross section, it can be driven into the soil easily.



**Fig. 4.14** *Timber pile*



**Fig. 4.15** *Composite pile*



**Fig. 4.16** *Steel piles*

A box pile is rectangular or octagonal. It is filled with concrete. When an H-Section pile is difficult to be driven, a box pile is preferred.

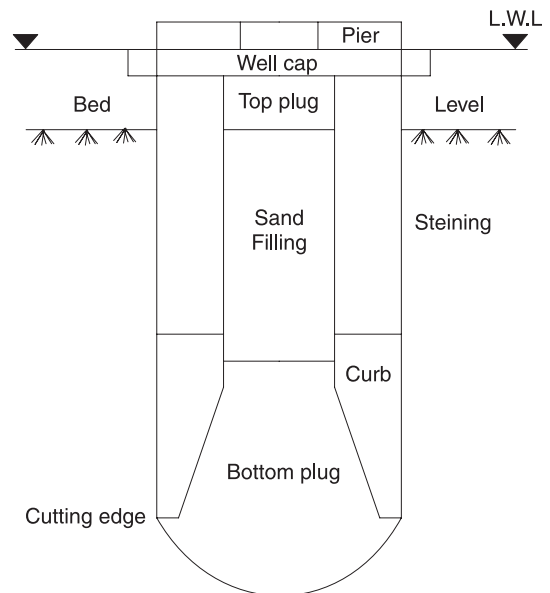
#### 4.9 CAISSON FOUNDATION OR WELL FOUNDATION

This is generally used for making foundations under water, such as ducks, bridges, etc. It is not a solid structure like a pier but is hollow inside, resembling a well. The load is transferred through the surrounding wall around called staining. The well is constructed and brought to the site. Then it is gradually driven down by digging the soil from inside. The bottom is plugged with concrete and the hollow portion is filled with sand. The whole well is then covered with a well cap above which the super structure is constructed.

A well foundations has the following advantages:

1. It can go to a large depth.
2. Its cost of construction is low.

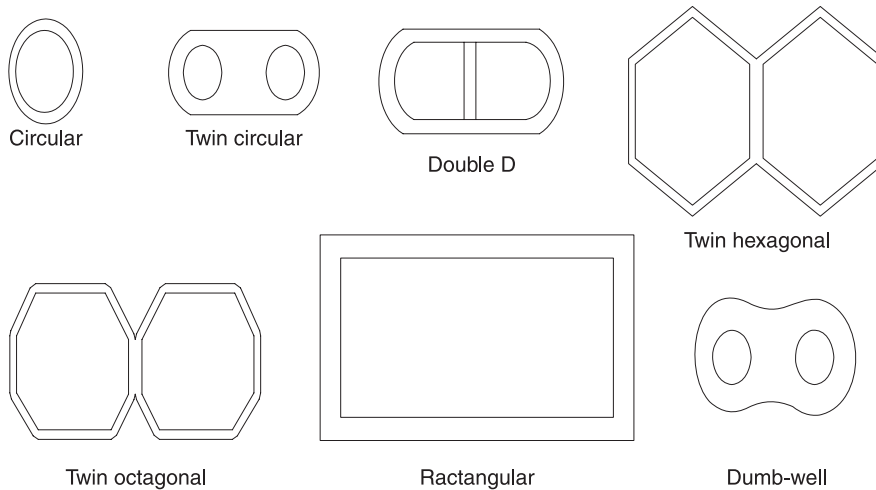
The typical section of a well foundation consists of cutting edge, well curb, bottom plug, staining, top plug and well cap, etc, as shown in Fig. 4.17.



**Fig. 4.17** *Well foundation*

There are different types of shapes of wells in plan such as,

1. Circular
2. Twin circular
3. Double D



**Fig. 4.18** Shapes of wells in foundation

4. Dumb well
5. Twin hexagonal
6. Twin octagonal
7. Rectangular

#### 4.10 FAILURE OF FOUNDATIONS AND REMEDIAL MEASURES

##### 1. Unequal Settlement of Subsoil

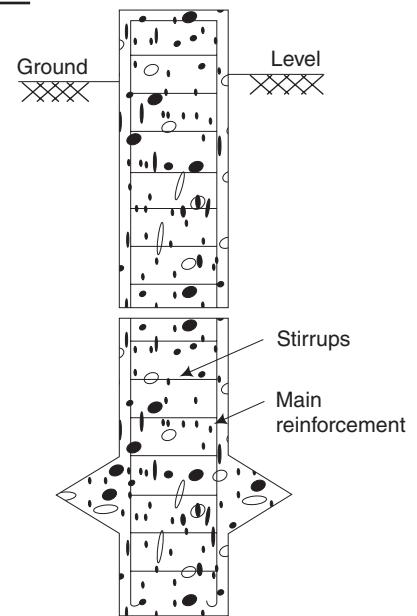
Due to unequal distribution of load on the foundations, varying bearing capacity of the soil, eccentricity of the load, etc., unequal settlement occurs. In order to prevent this, the foundations should rest on rock or hard moorum. Also, it should be seen that the allowable bearing pressure of the soil is not exceeded and proper attention should be given to the eccentricity of the load.

##### 2. Unequal Settlement of Masonry

Mortar joints may shrink and compress, which may lead to unequal settlement of the masonry. In order to avoid this settlement, the mortar to be used in the masonry should be stiff, the masonry should be raised evenly and should be watered properly.

##### 3. Withdrawal of Moisture from the Sub-Soil

This occurs at places where there is considerable variation in the height of the water table. The precaution needed to avoid this type of failure is to drive piles up to the hard-rock level.



**Fig. 4.19** Under-reamed pile

#### **4. Lateral Pressure on the Superstructure**

The thrust of a pitched roof or wind action on the superstructure causes the wall to overturn. The remedial measure is to provide a foundation of a suitable width.

#### **5. Horizontal Movement of Earth**

Very soft soil is liable to give way under the action of load. In such cases it is desirable to construct retaining walls or to drive sheet piles to prevent sliding of earth.

### **4.11 FOUNDATIONS FOR MACHINERY**

[May, June 2013]

The design of a machine foundation is more complex than that of a foundation which supports only static loads. In machine foundations, the designer must consider the dynamic forces caused due to the operation of machine, in addition to static loads. These dynamic forces are in turn transmitted to the foundation supporting the machine. The designer should therefore be well conversant with the method of load transmission from the machine, as well as with the problems concerning the dynamic behaviour of the foundation and the soil underneath the foundation.

#### **4.11.1 General Requirements of Machine Foundations**

The following requirements should be satisfied based on design considerations:

1. The foundation should be able to carry all the imposed loads without causing shear or crushing failure.
2. The settlements should be within the permissible limits.
3. The combined centre of gravity of machine and foundation should be in the same vertical line as the centre of gravity of the base plane.
4. No resonance should occur. Hence the natural frequency of foundation – soil system should be either too large or too small compared to the operating frequency of the machines. For low speed machines, the natural frequency should be high and vice-versa.
5. The amplitudes under service conditions should be within permissible limits.
6. All rotating and reciprocating parts of a machine should be well-balanced so as to minimise the unbalanced forces or moments.
7. Wherever possible, the foundation should be planned so as to permit a subsequent alteration of natural frequency by changing the base area or the mass of the foundation as necessary.

From the practical point of view, the following requirements should be fulfilled:

1. The groundwater table should be as low as possible and groundwater level should be deeper by at least  $1/4$  the width of foundation below the base plane. This limits the vibration propagation.
2. Machine foundations should be separated from adjacent building components by means of expansion joints.
3. Any steam or hot-air pipes embedded in the foundation must be properly isolated.

4. The foundation must be protected from machine oil by an acid-resisting coating or a suitable chemical treatment.
5. Machine foundations should be taken to a level lower than the level of the foundations of adjoining buildings.

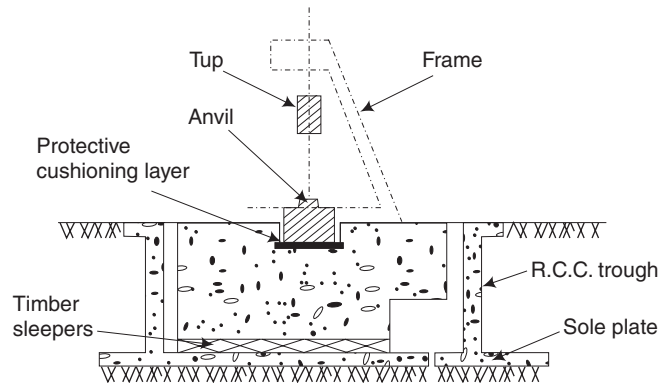
#### 4.11.2 Types of Machine Foundations

Machine foundations can be classified into three categories:

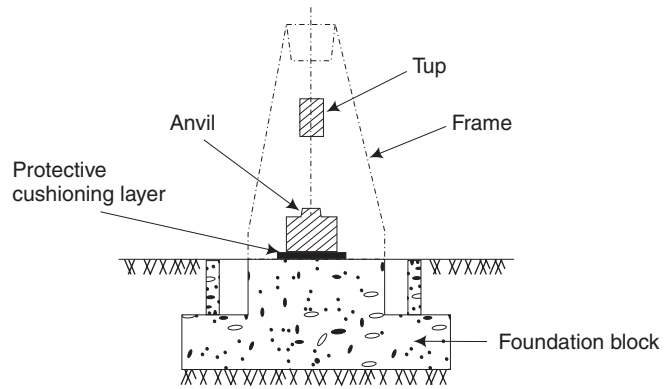
1. Block foundation usually adopted for reciprocating machines and light rotary machines.
2. Block and trough foundation for impact machines, such as drop and forge hammers.
3. Frame foundation generally adopted for heavy rotary machines, such as turbo generators.

#### 4.11.3 Foundations for Impact Type Machines

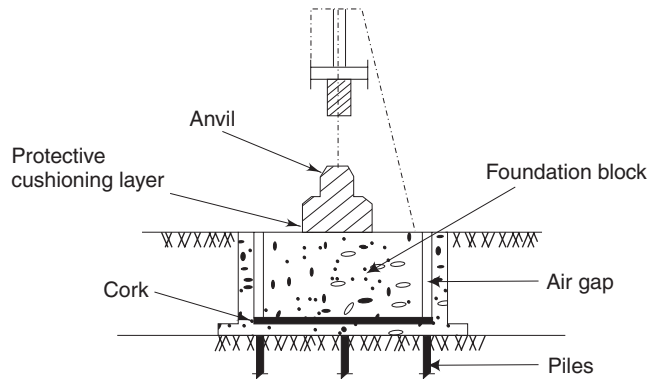
Three types of foundations for the drop or forge hammers are shown in Fig. 4.20. As shown in the figure, the frame supports the tup which is a weighted block striking the material being forged on the anvil. The anvil in effect is a base block for a hammer on which material is forged into shape by repeated striking of the tup. The anvil rests on a foundation block, which is a mass of reinforced concrete. The foundation block may rest directly on the ground as in Fig. 4.20 (b), or on a resilient mounting



(a) Foundation having an elastic support



(b) Foundation resting directly on soil



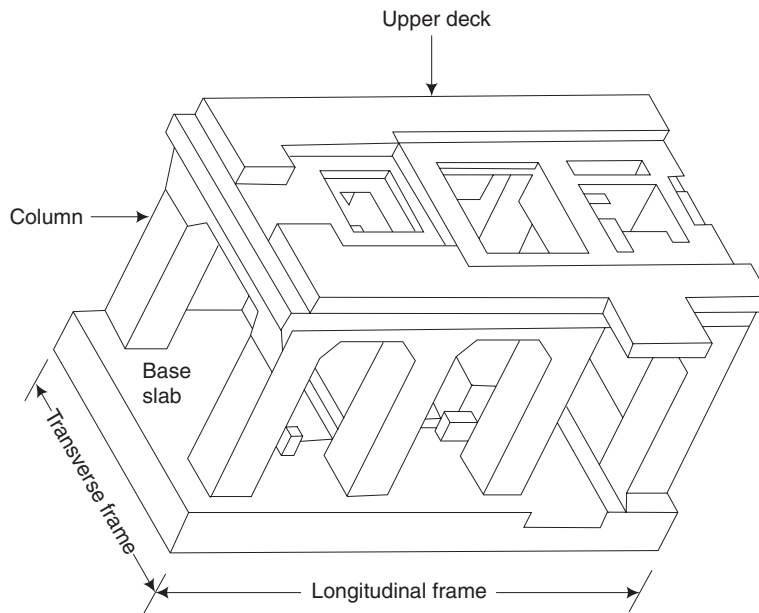
(c) Foundation resting on piles

**Fig. 4.20** Foundations for hammers

such as timber sleepers, springs, cork layer, or any soft insert as shown in Fig. 4.20 (a). The RCC trough containing the foundation block may rest on a sole plate or may be carried on piles as in Fig. 4.20 (c). An elastic cushioning of suitable material and thickness is provided between the anvil and the foundation block in order to prevent bouncing of the anvil and creation of large impact stresses and consequent damage to the top surface of the concrete in the foundation block. This is shown as protective cushioning layer in Fig. 4.20 (c).

#### 4.11.4 Foundation for Heavy Rotary Type Machines

The design of a foundation for heavy rotary type machines, such as steam turbo generators, involves vibration considerations which are generally complicated. Special features relating to the design of such foundations should be advised by the manufacturers. These machines are generally supported on frame foundations as shown in Fig. 4.21.



**Fig. 4.21** Typical frame foundation for turbo generators

A heavy base slab is advantageous in the damping of the vibrations. The effective thickness of the base slab is kept at least  $1/10$  of its length, or the minimum width of the column. The weight of the base should not be less than the total weight of the machine plus the weight of the foundation without the base slab.

The soil stress should be restricted to 50–70 per cent of the allowable stress under static load. Wider contact of foundation with the soil is preferable. It is suggested that the foundation at contact with the machine base should be at least 150 mm larger than the



base all around. The depth of foundation is 0.75 m in the ground even for inconsequential machines and more for larger machines.

For reciprocating machines, rigid block types are generally used. It is advisable to make the entire block in one operation without a construction joint. It is advisable to provide a nominal reinforcement of about 0.2 per cent of the cross-sectional area in the axes of displacement.

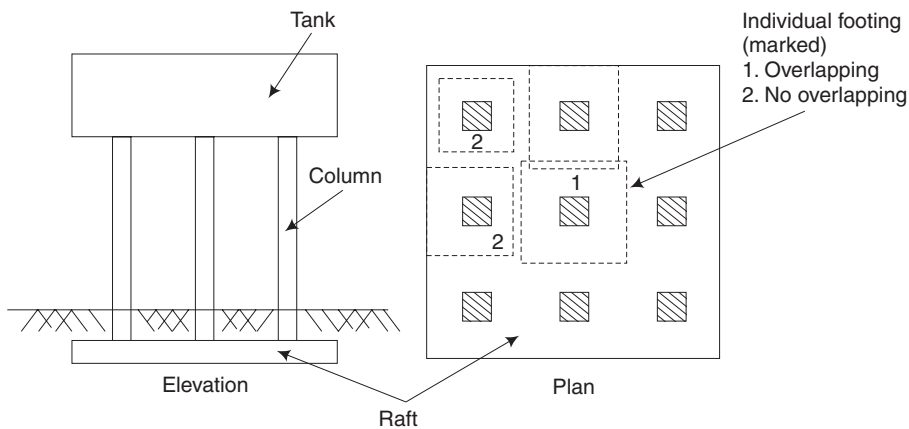
Machine foundations should normally be isolated from the neighbouring structure by an air gap or with soft inserts.

## 4.12 FOUNDATIONS FOR SPECIAL STRUCTURES

By special structures we mean unconventional or rarely occurring structures such as buildings. There are a number of such special structures, which may be above or below ground, on-shore or off-shore, civil or defense, and commercial or industrial. The foundations for some special structures is discussed in the following sections.

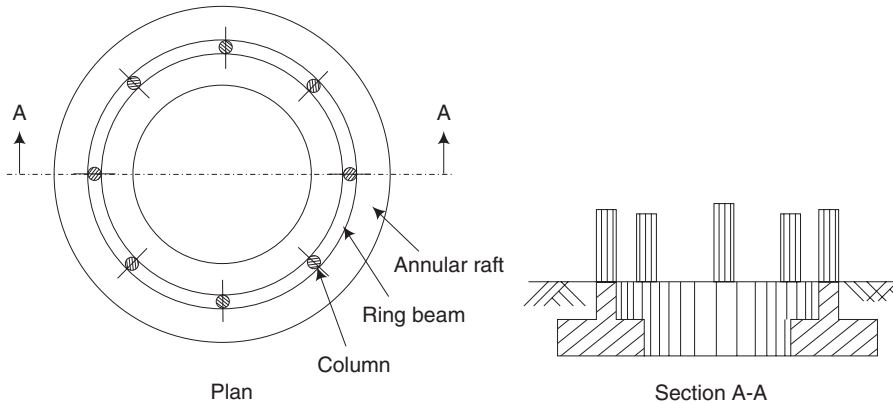
### 4.12.1 Foundations for Water Tanks and Silos

Overhead structures like water tanks, grain silos, etc., which are supported on columns can be considered as an example of special structures. The columns of these structures can be founded on soil by means of footings, rafts (or mats) of the beam and slab type or flat slab type, piles or piers, with cap, depending upon the load and soil conditions (Fig. 4.22). When footings are used, strap beams may be provided to connect the columns at their base and to overcome the effects of differential settlements. Under conditions of heavy loads, weak soil and closely spaced columns, individual footings if overlap have to be ruled out and a raft becomes a necessity. Even when the footings do not overlap, but cover more than half the base area, a raft proves to be a more economical system than that of individual footings.



**Fig. 4.22** Raft foundation for overhead water tanks

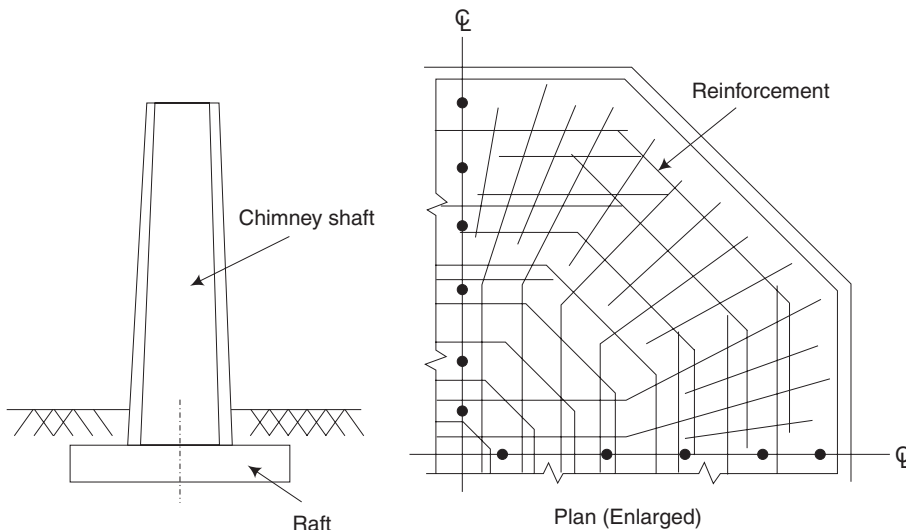
When the columns form a circular row, a circular or annular raft is very often used as the foundation on to which the load is transmitted as a circular line load through a ring beam, which supports the columns. Figure 4.23 shows such a foundation.



**Fig. 4.23** *Annular raft foundation*

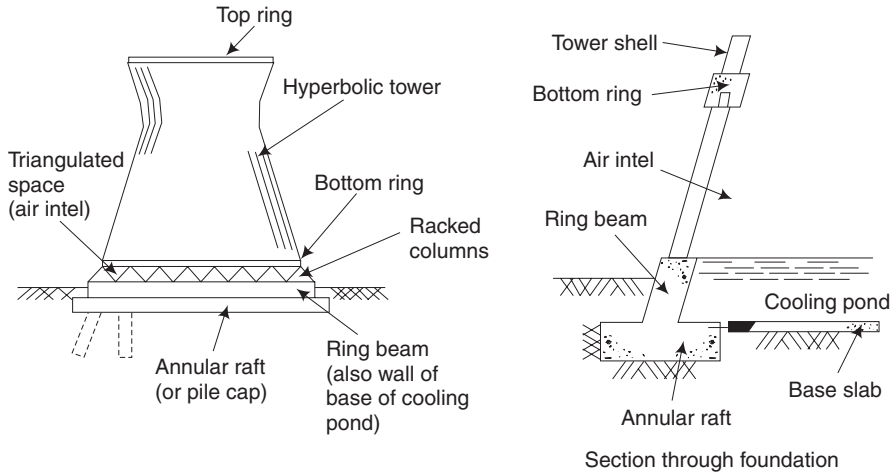
#### 4.12.2 Foundations for Chimneys and Cooling Towers

Tall cylindrical structures such as chimneys are normally founded on circular rafts, when the soil conditions are favourable. For facilitating construction, these circular rafts are normally detailed octagonally. Figure 4.24 shows this type of foundation.



**Fig. 4.24** *Octagonal raft for chimney*

Cooling towers, are normally in the form of a hyperboloid of revolution and are usually found in thermal power stations. Figure 4.25 shows such a foundation. An annular raft may prove to be a convenient foundation for such towers on good soil. Deep foundations, if needed, could be of piles or caisson.



**Fig. 4.25** Foundations for cooling towers

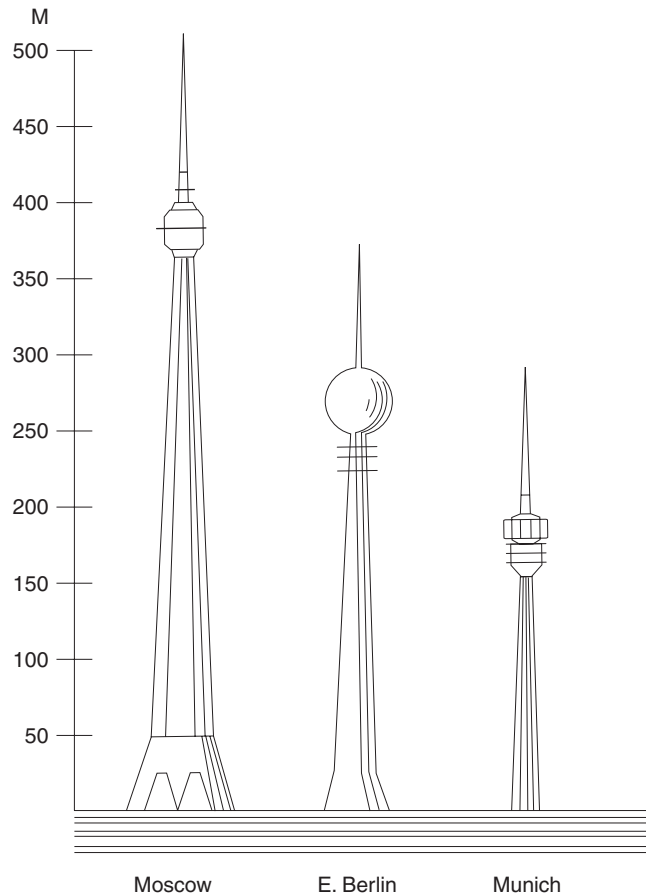
### 4.12.3 Foundations for Telecommunication Towers

Tall reinforced concrete telecommunication towers for television, radio, telephone (microwave), etc., are normally founded on an annular raft through a conical substructure. In addition to the flexural effect due to soil reaction, the foundation ring is also subjected to hoop tension due to the horizontal component of the inclined thrust from the cone. To resist this, prestressing is sometimes resorted to. The tallest of these structures is the Moscow TV Tower at Ostankino shown in Fig. 4.26. This structure has a total height of 533 m and a weight of 550 MN. It has a ring foundation (decagonal, prestressed) with an outside diameter of 74 m and a thickness of 9.5 m. It is founded at a depth of 3.5 m below the ground level, to a mean soil pressure of  $274 \text{ kN/m}^2$ . The foundation soil is compressible to a depth of 35 m, which has incompressible rock underneath.

Even though reinforced concrete telecommunication towers are very popular in Europe, particularly in West Germany, but similar towers in India are practically made of steel and are mostly founded on piles.

### 4.12.4 Foundations for Transmission Line Towers

All tall tower-shaped structures are subjected to large horizontal forces due to wind. These horizontal forces transmit both horizontal loads and moments at the foundation level. (In a general case, even twisting moments can be transmitted.) When the vertical

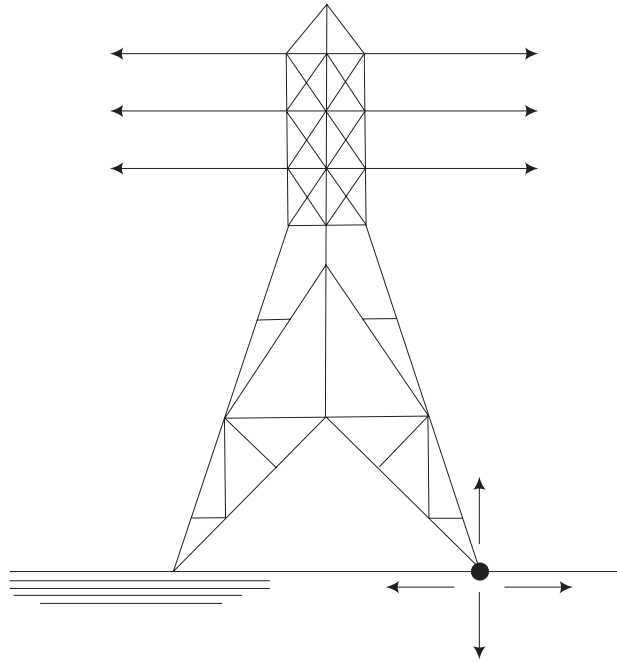


**Fig. 4.26** Conical substructure for telecommunication towers

loads are comparatively smaller, these moments can produce a resultant tension in the foundation elements such as footings and piles. Wind may not always act and in a general case, it may act in any direction. Hence, the soil and structural aspects of the design of the concerned foundation element should cater simultaneously to the maximum values of compression, tension and horizontal forces, which may also act in either direction as explained in Fig. 4.27.

Some typical foundations for transmission line towers are illustrated in Fig. 4.28. For small towers the foundation can be in the form of blocks into which the tower legs are properly anchored. Individual reinforced concrete footings or combined footings may have to be used for higher loads.

Under-reamed piles which are normally used as foundations in expansive soil can be effectively used as foundations for the legs of transmission line towers even in ordinary soil. They can be used either as a single pile or in a group, depending upon the load and



**Fig. 4.27** *Transmission line tower: Forces on foundation*

the capacity of the individual pile. The function of these piles in expansive soils is to transmit the loads to the stable zone which lies under the zone susceptible to swelling and shrinkage due to moisture variation. When the loads are compressive, the under-ream or the bulb serves to increase the bearing area, while under tension it serves as an anchor for the pile in the stable zone. This dual function explains the effectiveness of under-reamed piles as potential foundations for transmission line towers.

Following are the different foundations for transmission line towers as shown in Fig. 4.28.

- (a) Block foundation
- (b) Piled foundation with capping block
- (c) Pillar foundations
- (d) Augered belled foundation
- (e) Footing
- (f) Anchored leg
- (g) Grillage foundation
- (h) Combined footing (elevation)
- (i) Beam and slab raft (Plan)
- (j) Under-reamed piled foundations
- (k) Screw pile foundation

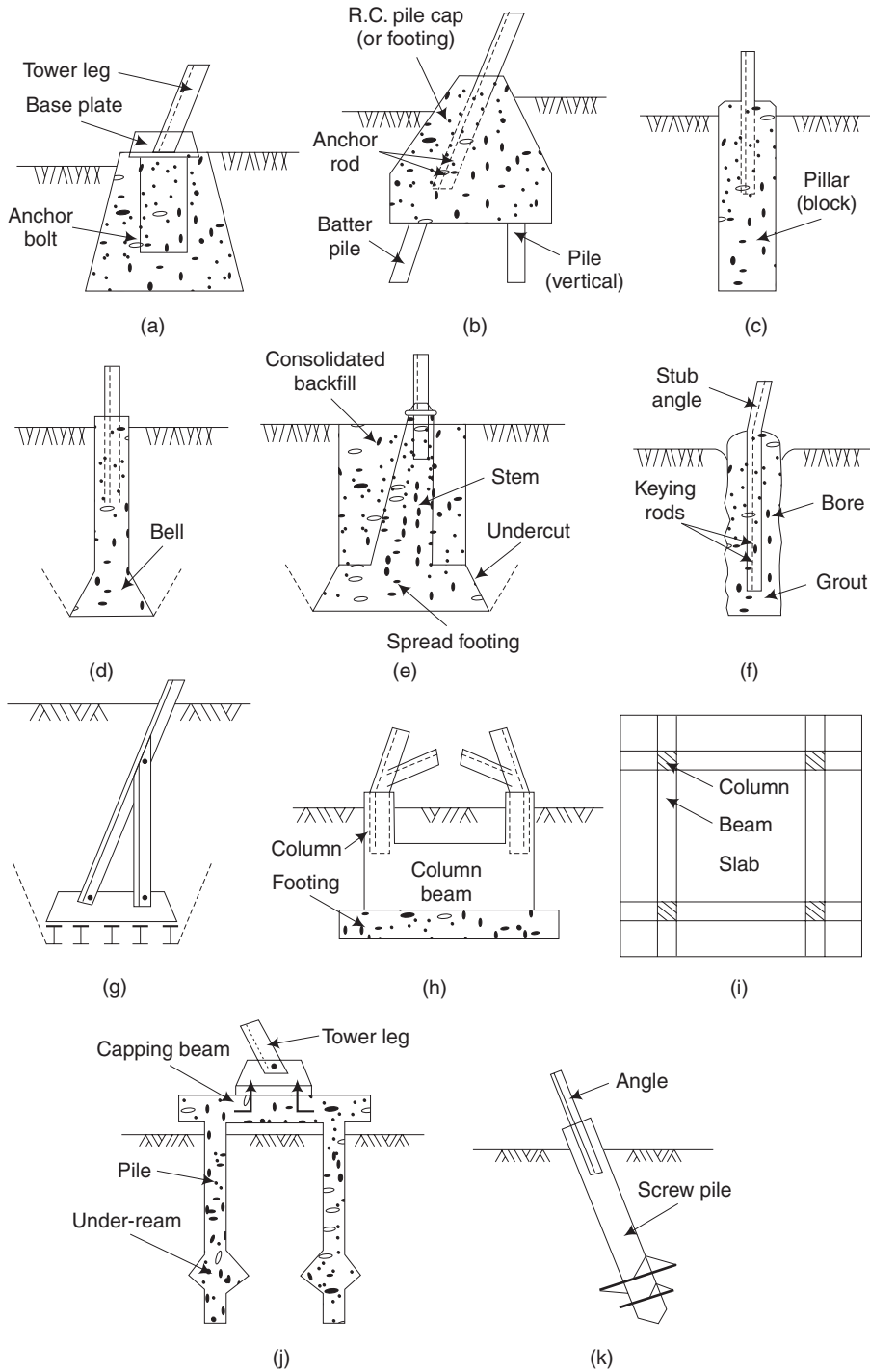
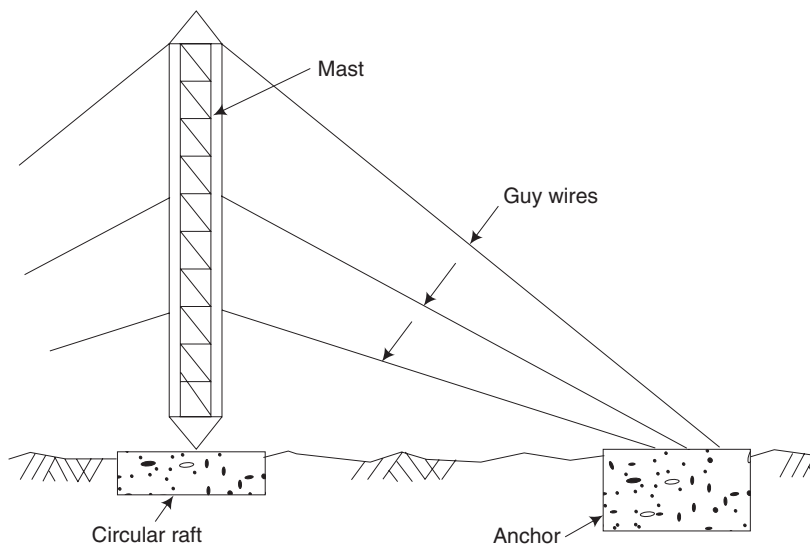


Fig. 4.28 Foundations for transmission line towers

#### 4.12.5 Foundations for Guyed Structures

Guyed steel masts and towers are often used to carry radio antennas and for similar telecommunication purposes. The guy wires serve to absorb all horizontal forces. This helps to reduce the structural sections of the mast towards the lower part which would have otherwise been heavy due to the high moments from the horizontal forces, besides arresting the sway of the mast which is not desirable from the functional point of view. Not only masts, but stacks are also sometimes guyed. A minimum of three guy wires ( $120^\circ$  apart) are needed in all cases. If necessary, guy wires can be taken from more than one location on the mast. While the mast itself may be supported on a plain circular footing or a conical shell rooting (upright or inverted) the guy wires should be terminated at suitable anchors (Fig. 4.29). These anchors may take the form of block footings, piles or piers depending upon the capacity required. The anchors are used to resist the vertical and horizontal components of the inclined tension in the guy wires. The magnitude of the vertical component of the tension can be brought down by keeping the angle of the wire (from the horizontal) as low as practicable, but this would be at the expense of extra length and increased horizontal force.

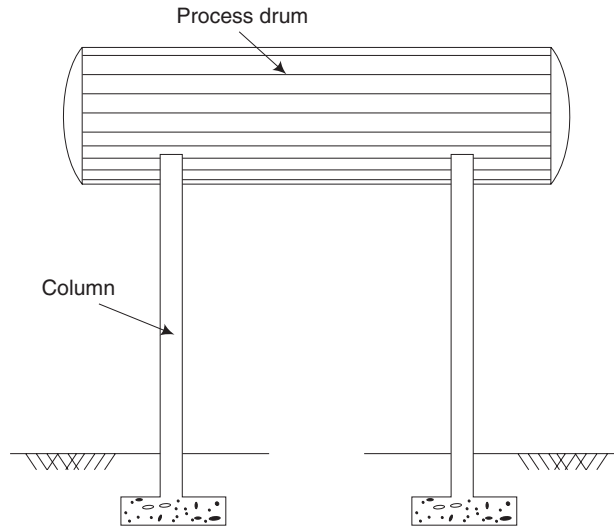


**Fig. 4.29** Guyed mast

#### 4.12.6 Foundations for Industrial Structures

Industrial structures, particularly those found in chemical and processing industries, pose a number of problems not normally encountered in case of ordinary residential and commercial structures. These are mainly in the form of forces which include not only wind forces, fluid thrust, etc. but even forces created by thermal expansion and contraction. Structures in this group include process towers and stacks supported on octagonal footings

or pile groups, drum exchangers, pipe lines and bents which may be above ground, on ground or below ground. Figure 4.30 shows such a type of foundation.



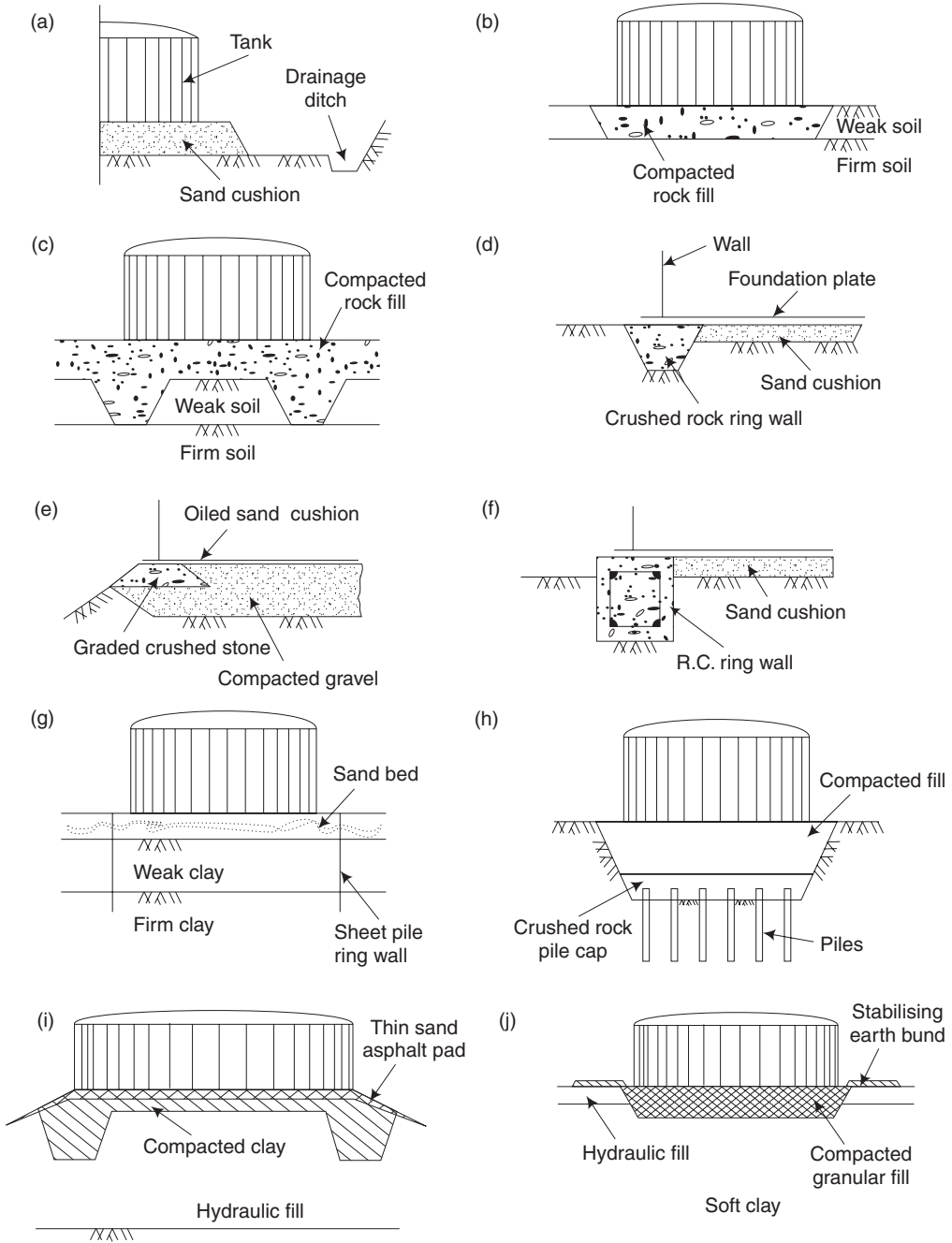
**Fig. 4.30** Foundation for an industrial process drum

#### 4.12.7 Foundations for Ground Storage Tanks

Cylindrical ground storage tanks of substantial dimensions for fluids, are used in petroleum refineries, chemical plants and many other manufacturing industries, for storing both raw materials and finished products. These tanks are made of thin steel plates welded together. They are basically of two types, i.e., with floating roof and with fixed roof.

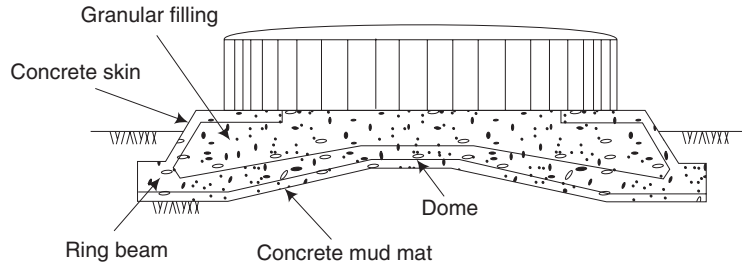
These storage tanks present special foundation problems, as they are often required to be founded on soft coastal and estuarine soils. The tanks are relatively very light compared to the material (fluid) stored in them. Since the bottom plates are sufficiently flexible, they are able to transmit their liquid load on to the soil without much structural interaction. Since the bulb of pressure can extend to considerable depths depending upon the diameter of the tank, settlements of the order of a metre are common in the case of larger tanks. Oil companies, however, are wary of adopting pile foundations in such soils, as the cost of the foundation can exceed by several times the cost of the tank itself. Hence, attempts are normally directed to make the foundation as cheap as possible and consistent with performance. Among the several types of foundations available, those with oiled sand pad, crushed rock or concrete ring wall, interlocking sheet pile ring wall and piled foundations with crushed rock pile cap are suitable types for soils in the order of their decreasing quality. Some of these types are illustrated in Fig. 4.31. The advantage of providing thicker foundation bases lies in dispersing the load mostly through the base, thereby reducing the bearing pressure on the soil below.





**Fig. 4.31** *Ground storage tank foundations*

An ingenious foundation incorporating a thin reinforced concrete dome as an economic alternative to pile foundation is illustrated in Fig. 4.32.



**Fig. 4.32** Durley dome foundation for oil storage tanks

### Short-Answer Questions

1. A column transmits a load of 2800 kN. The safe bearing capacity of the soil is 400 kN/sq.m. What are the dimensions of the foundation required.
2. Which materials are usually used for friction piles?
3. Name the foundation that may be adopted for expansive soils.
4. Distinguish between shallow foundation and deep foundation.
5. What are the points to be considered while selecting the site for any particular building?
6. List the types of machine foundations.
7. Define safe bearing capacity.
8. What are the essential requirements of a good foundation?
9. What are the different loads acting on the foundation of a building?
10. Under what circumstances is a combined footing preferred to an isolated one?
11. Explain the following types of foundations with neat sketches.
  - (a) Isolated footing
  - (b) Combined footing
  - (c) Under-reamed pile foundation
12. What are the usual causes of failure of foundations?
13. Write short notes on IS classification system for soil.
14. Under what circumstances stepped footings are provided?
15. What is simple footing?
16. How will you calculate the width and depth of a shallow foundation?
17. What do you mean by special structures?
18. Give some examples of special structures.
19. Under what conditions does raft foundation become necessary?

20. What are the functions of guy wires in masts and towers?
21. In what ways do under-reamed piles serve as potential foundations for transmission line towers?

### *Exercises*

1. List the objectives of a foundation.
2. Explain under what conditions can an isolated footing be adopted.
3. What is a deep foundation?
4. Explain under what circumstances a pile foundation is adopted.
5. What are the basic needs of a foundation for a machine?
6. Explain with neat sketches the block foundation used for impact-type machines.
7. Explain the classification of soils in detail.
8. Describe briefly the methods for improving the bearing capacity of the soil.
9. Describe briefly strip footing with a neat sketch.
10. Explain with neat sketches, the raft foundation for water tanks.
11. Briefly explain the foundations for
  - (i) Chimneys and cooling towers
  - (ii) Telecommunication towers
12. Explain in detail some typical foundations for transmission line towers with neat sketches.
13. Give a detailed account on foundations for
  - (i) Guyed structures
  - (ii) Industrial structures
14. With neat sketches, explain the various types of foundations for ground storage tanks.



# Chapter 5

## SUPERSTRUCTURE

### 5.1 INTRODUCTION

The superstructure consists mainly of walls, doors, windows and lintels. The purpose of the superstructure is to provide the necessary utility of the building, structural safety, fire safety, sanitation and ventilation.

The art of construction in stone or in brick is called masonry. The former is called stone masonry while the latter is called brick masonry.

### 5.2 BRICK MASONRY

#### 5.2.1 Technical Terms

Some of the common terms used in the brick masonry are illustrated in this section in Fig. 5.1(a) and Fig. 5.1(b).

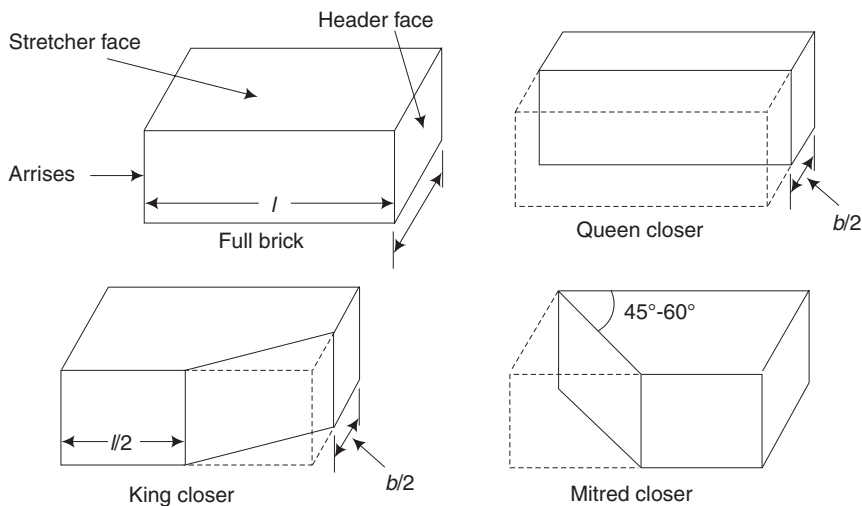
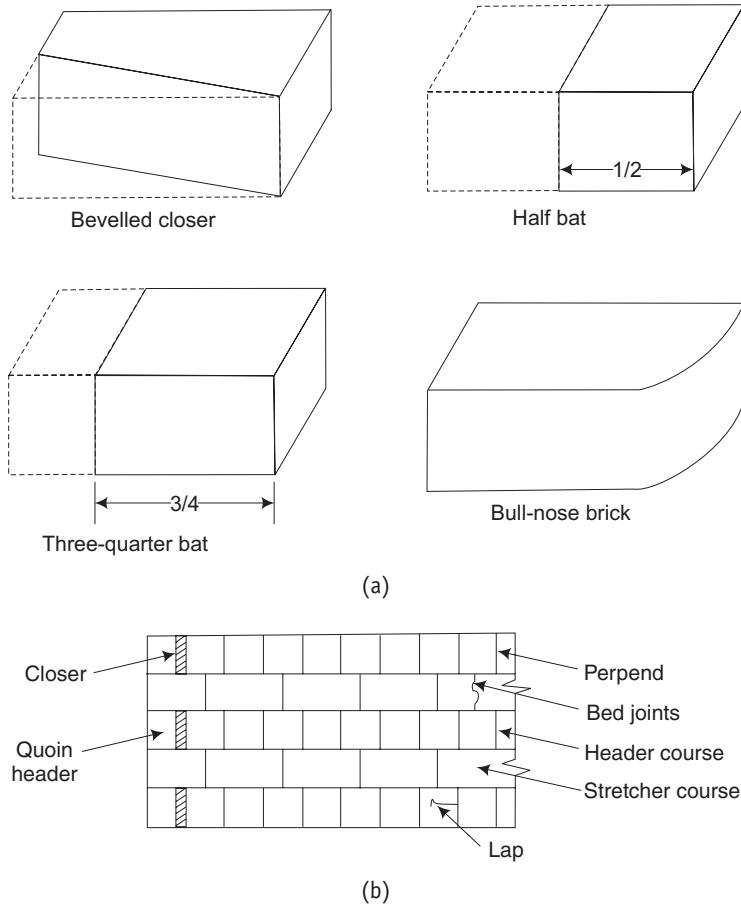


Fig. 5.1 (contd.)



**Fig. 5.1** Components of brick masonry

**Arrises** The edges formed by the intersection of plane surfaces of a brick are called arrises.

**Stretcher** This is a brick laid with its length parallel to the face or direction of a wall. A layer of bricks containing stretchers is called a stretcher course.

**Header** This is a brick laid with its breadth or width parallel to the face or direction of a wall. A course (layer of bricks) containing headers is a header course.

**Bed joint** The horizontal layer of mortar upon which bricks are laid is called a bed joint.

**Perpends** The vertical joints either in the length or in the cross directions are known as perpends. For a good bond, the perpends in alternate layers should be one above the other.

**Lap** The horizontal distance between the vertical joints in two successive courses is termed as lap.

**Closer** A piece of brick that is used to close up the bond at the end of brick courses is known as a closer. It helps preventing the vertical joints of successive courses coming one over the other. The types of closer are the following:

1. **Queen closer** This is obtained by cutting the brick longitudinally into two equal parts. This is generally placed near the quoin header to obtain necessary lap.
2. **King closer** This is obtained by cutting a triangular portion of the brick such that half a header and half a stretcher are obtained on the adjoining cut faces. A king closer is used near door and window openings to get satisfactory arrangement of mortar joints.
3. **Bevelled closer** This is obtained by cutting a triangular portion of half the width but of full length of the brick. This is used for splayed brick work.
4. **Mitred closer** This is obtained by cutting a triangular portion of the brick through its width and making an angle of  $45\text{--}60^\circ$  with the length of the brick. It is used at corners, junctions etc.

**Bat** This is a piece of brick cut parallel to its width so as to form half or three quarter of a brick known as half bat or three-quarter bat.

**Bullnose** A brick moulded with a rounded angle is termed as a bullnose and it is used for a rounded quoin.

**Cownose** A brick moulded with a double bullnose on end is termed as a cow nose.

**Squint quoin** A brick which is cut or moulded in such a way that an angle other than right angle is formed in the plan is known as squint quoin.

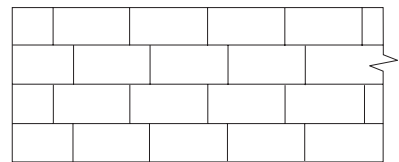
### 5.2.2 Bonds in Brick Work

[Nov, Dec 2011]

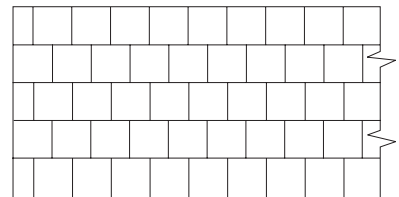
A bond is an arrangement of layers of bricks by which no continuous vertical joints are formed. Bricks can be arranged in various forms. The following are the types of bonds in brick work:

1. **Stretcher bond** All the bricks are arranged in stretcher courses. The stretcher bond is useful for one-brick partition walls as there are no headers in such walls. As the internal bond is not proper, this is not used for walls of thickness greater than one brick. A stretcher bond is shown in Fig. 5.2.

2. **Header bond** In this type, all the bricks are arranged in header courses. It is used for curved surfaces since the length will be less. If a stretcher bond is used in a curved surface, it will project beyond the face of the wall. Figure 5.3 shows a header bond.



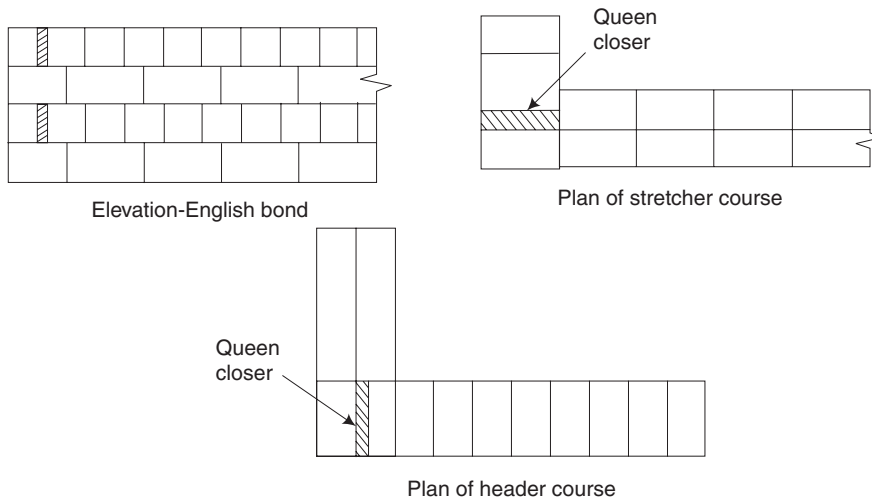
**Fig. 5.2** *Stretcher bond*



**Fig. 5.3** *Header bond*

### 3. English bond

#### (a) One-brick wall



**Fig. 5.4** English bond (one brick wall)

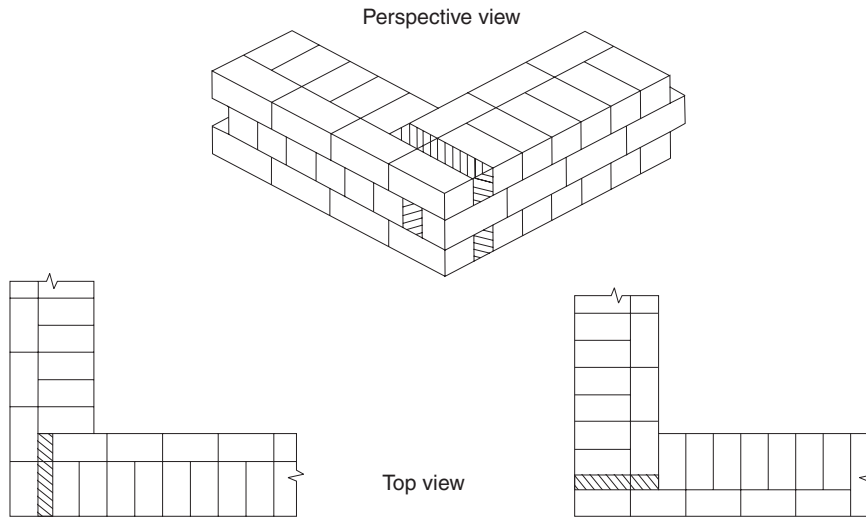
English bond is the most commonly used type of bond. It is the strongest type of bond. It is used for all wall thicknesses.

- (a) **Alternate Courses** English bond consists of headers and stretchers in alternate courses in elevation.
- (b) **Queen Closer** A queen closer is placed next to the quoin header, in each header course to the full thickness of the wall. This is done to break the continuity of the vertical joints in the successive courses. Thus, a lap joint is provided to create the bond.
- (c) **Alternative Header** Each alternative header lies centrally over a stretcher of the stretcher course.
- (d) **Wall Thickness in Even Number of Half-Bricks** If the wall thickness is an even number of half-bricks, the same course will show either headers or stretchers on both the face and back. That is, the appearance on both face and back are the same.
- (e) **Wall Thickness in Odd Number of Half-Bricks** If the wall thickness is an odd number of half-bricks, the same course will show headers of the face and stretchers on the back or stretchers on the face and headers on the back of the wall.
- (f) **Continuous Vertical Joints** Continuous vertical joints should not be allowed except at the stopped end.
- (g) **Wall Thickness of Two Bricks or More** For walls of thickness of two bricks or more, the interior or hearting of these thicker walls should be filled with headers only.



(h) **Thinner Header Course** There are more vertical joints in the header course than in stretcher course. Hence, the joints in the header course should be thinner than in the stretcher course.

(b) **One-and-a-half brick wall** In English bond, stretcher and header courses are laid alternately in the facing of the wall. In this, the queen closer is placed next to the quoin header to break the continuity of the vertical joints. Each alternate header is centrally placed over a stretcher. If the thickness of the wall is an even number of half brick, the wall presents the same appearance on both the faces, otherwise the same course will present stretchers on one face and header on the other (Fig. 5.5).



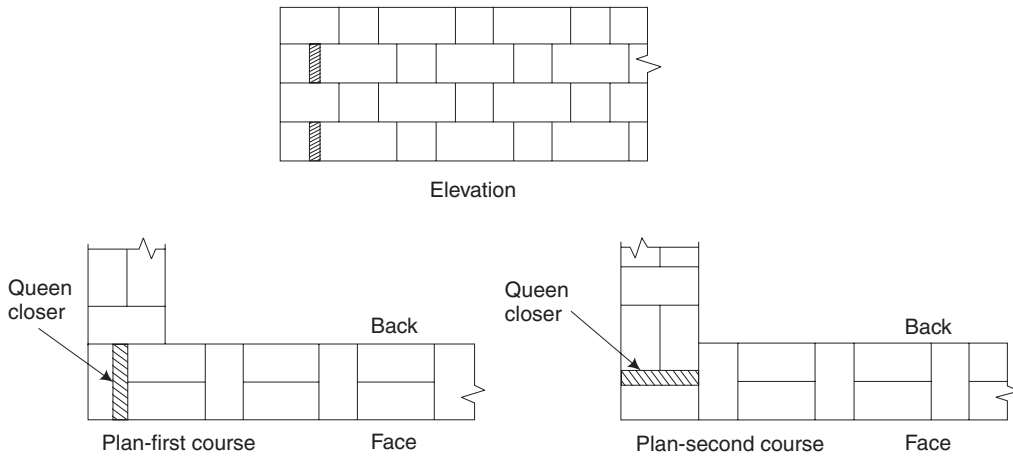
**Fig. 5.5** *One-and-a-half brick wall in English bond*

**4. Flemish bond** In this type of bond, the headers are distributed evenly as shown in Fig. 5.6 and hence creates a better appearance.

The peculiarities of a Flemish bond are as follows:

- (a) In every course headers and stretchers are placed alternately.
- (b) The queen closer is put next to the queen header in alternate courses to develop the lap.
- (c) Every header is centrally supported over a stretcher below it.
- (d) The Flemish bond may be either a double Flemish bond or a single Flemish bond.

In a double Flemish bond, headers and stretchers are placed alternately in front as well as in rear elevations. For this type of bond, if the wall thickness is equal to an odd multiple of half bricks, then half bats and three quarter bats have to be used. For walls of thickness equal to even number of half bricks, no bats will be required. A stretcher or a header in the front elevation will appear as a stretcher or header in the rear elevation also. This has a better appearance than the English bond but not so strong as the English bond.



**Fig. 5.6** *Flemish bond— one-brick thick wall*

A single Flemish bond consists of a Flemish bond in the front and an English bond in the rear along with the filling. This type of bond is used when expensive bricks are used for the front and requires a minimum wall thickness of  $1\frac{1}{2}$  bricks.

- (e) As in the English bond, the bricks in the same course do not break the joints with each other and the joints are straight.
- (f) In this bond, short continuous vertical joints are formed.
- (g) Brick bats are to be used for walls having a thickness equal to uneven multiple of half bricks.

### **Comparison of English Bond and Flemish Bond**

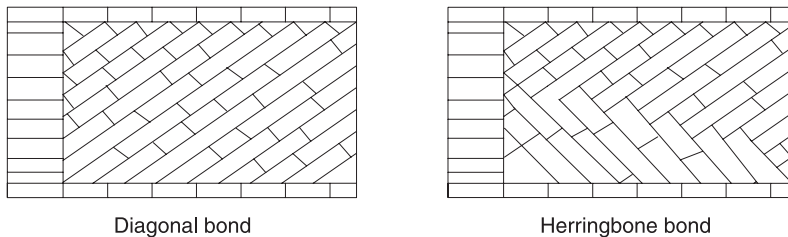
Sl.No	Aspects	English Bond	Flemish Bond
1.	Strength and wall thickness	Strength is more, for walls of thickness $1\frac{1}{2}$ bricks or more	Strength is more, for walls of 1 brick thickness; for thicker wall, strength is less
2.	Appearance	Appearance on the facing is not pleasing	Appearance on the facing is more pleasing and uniform
3.	Stretchers and headers	Alternate courses of stretchers and headers	Alternate arrangement of a stretchers and a header in each course
4.	Cost	More costly, as less number of brick bats are used	Less costly since a large number of bats are used
5.	Breaking of joint	Maintaining of correct breaking of joint is difficult	Maintaining of correct breaking of joint is easy
6.	Labour	Skilled labour is not required; hence, it is easy and fast to construct.	More skilled and experienced labour is required
7.	Mortar	Less mortar is used	More mortar is required

## 5. Raking Bonds

In this type of bond, the bonding bricks are kept at an inclination to the direction of the wall. The raking course is generally provided between the two stretcher courses. This bond is used in thick walls.

Raking bonds are two types:

1. Diagonal bond
2. Herringbone bond



**Fig. 5.7**

Raking bonds are used for thick walls. These are of the following two types:

### 1. Diagonal bond

See Fig. 5.7. In this bond, bricks are laid diagonally. Internal placing of bricks is made in one direction only at certain angle of inclination, after face bricks are laid. The angle selected is to ensure minimum breaking of bricks.

### 2. Herringbone bond

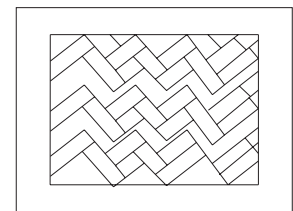
In this bond, the bricks are laid at an angle of 45° from the centre in both the directions.

## 6. Zig-Zag Bond

See Fig. 5.8. In the bond, the bricks are laid zig-zag. This method is used for paving or making ornamental finish in the brick floor.

Bricks cut to triangular shapes and of suitable size are packed in the small triangular spaces at the ends.

**Garden Wall Bond** This type of bond is used for the construction of garden walls, boundary walls, compound walls, where the thickness of the wall is one brick and the height does not exceed two meters.

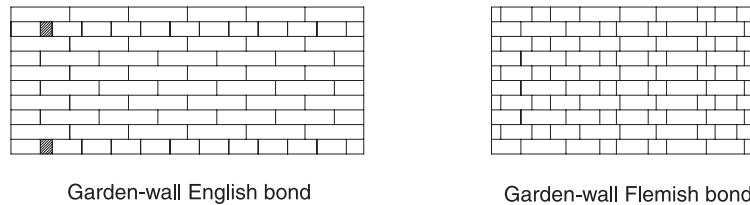


Zigzag bond

**Fig. 5.8**

Garden wall bonds are two types:

- (i) Garden wall English Bond In this bond, the header course is provided only after three to five stretcher courses.
- (ii) Garden wall Flemish bond In this bond, each course contains one header after three to five stretchers continuously placed throughout the length of the course.



**Fig. 5.9** *Garden-wall bond*

### 5.2.3 Dimensions of a Brick Masonry Wall

In order to make a brick masonry wall safe, its thickness must be sufficient enough to withstand the loads coming on it. The loads acting on a wall are dead loads, live loads, and wind loads. The vertical loads may be concentric or eccentric.

The tendency of the wall to overturn due to the effect of wind pressure depends on the overall height of the wall. The distance between the top of floor concrete and the highest part of the wall is the overall height. The height of a floor is also important while designing a wall. For domestic buildings, the floor height may be 3-4 m.

The length of the wall is fixed on the basis of its tendency to buckle laterally. Its thickness also depends on the strength of bricks as well as the strength of cement mortar.

### 5.2.4 Points to be Observed while Supervising the Construction of Brick Work

1. The bricks to be used should conform with the requirements of the specification of the work.
2. The bricks should be saturated with water so as to prevent absorption of moisture from the mortar.
3. Bricks should be laid with the frog located uppermost and the mortar should completely cover the bed.
4. Brick work should be carried out in a proper bond.
5. The mortar to be used should be of good quality.
6. The brick work should be raised uniformly.
7. In brick work, brick bats should not be used except as closers. All brick bats of size less than half brick should be rejected.
8. Single scaffolding should be adopted to carry out brick work at higher levels.
9. The vertical faces should be checked with a plumb bob and the inclined faces should be checked with the templates.
10. After construction, brick work should be well watered for a period of about two to three weeks if lime mortar is used and for about one to two weeks if cement mortar is used.

### 5.2.5 Cracks in a Brick Masonry Wall

In most of the structures cracks appear in a brick masonry wall due to the following reasons:

1. Combining the brick work with other materials having greater deflections and strains.
2. Effect of deflection and shrinkage of the concrete slabs resting on walls.
3. Development of internal forces due to moisture absorption, temperature variations, etc.

The measures to prevent cracking in masonry walls are given below:

1. The foundation supporting masonry walls should be designed with sufficient stiffness.
2. The provision of horizontal and vertical expansion joints in the walls helps in reducing the occurrence of cracks.
3. The usage of concrete with low shrinkage characteristics also prevents cracking.
4. It is preferable to have short spans for the floor slabs.

## 5.3 STONE MASONRY

Stone is a natural choice for masonry, where it is available in plenty. Its durability has been demonstrated in our temples and massive structures. Coal tar, paraffin, linseed oil or solution of alum and soap are the preservatives used to prevent the stone from the effects of rain water, wind, etc.

Stone masonry is the construction carried out using stones with mortar. But, because of high cost of transportation, painful and costly work of dressing and the need for experienced labour, stone masonry is presently not popular. Further, stone-masonry walls occupy more space compared to brick-masonry walls.

### *Types of Stones*

Types of stones used in stone masonry are

- Dense stones like granites and quartzite
- Fire-resistant stones and sandstones
- Soft stones like limestone, marble and slate used for carvings, arches, etc.

### *Uses of Stone Masonry*

- Foundation, floor, walls, lintels, columns, roofs, etc.
- Walls, roofs, lintels for temples, monuments, etc.
- For facing works in brick masonry to give massive appearance

### 5.3.1 Dressing of Stones

After quarrying, stones are to be dressed for surface finish. Dressing of stones is the art of cutting the stones to the shape required for use in the structures. It is done at the quarry itself. Quarry dressing has the following advantages in comparison to sit dressing:

- Cheap labour is available at the quarry site.
- Freshly quarried stones contain some moisture called quarry sap. Hence, they are comparatively soft and can be easily dressed.
- It is possible to sort out the stones at the quarry for different works. Irregular and rough portions of the stones can be removed then and there in the quarry. Thus, the weights of the stones as well as transportation of stones are reduced.

#### ***Tools used for dressing of stones***

*Hammers* Mason hammer, scrabbling hammer, mash hammer, waller's hammer, spalling hammer, fare hammer

*Chisels* Crow chisel, soft stone chisel, draught chisel, plain chisel, splitting chisel, punch chisel and point chisel

*Axes*

*Punching machine*

***Types of dressing*** Stones for different types of stone masonry are dressed as follows:

#### 1. *Hammer Dressing*

For rubble masonry, stones are roughly dressed with hammers. The surface thus obtained is called hammer-dressed. The stones are made roughly square or rectangular or polygonal using a waller's hammer. The exposed face of the stone may be roughly shaped by using a mash hammer. The lower and upper surfaces of the stones are almost dressed flat.

#### 2. *Chisel Dressing*

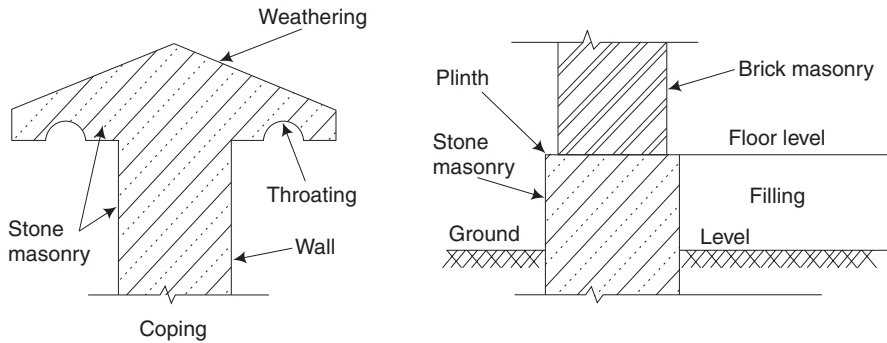
For good Ashlar masonry, the faces of stones are finely dressed by means of chisels. A draught chisel is sunk round the margin of the stone. Its front face is dressed to rock face. Sometimes, to make the entire face truly smooth, chisel draughts are sunk diagonally on the stone face and the intermediate portions are brought down to a level with the help of dressing tools. At length, the chisel marks are removed by rubbing the surface with a stone slab and fine sand.

#### 3. *Axed Finish*

Axed Finish is employed in hard stones like granites. An axe is used for the dressing operation.

#### 4. *Polished Finish*

Granite, marble and trap take a good polish. This is achieved manually or by the aid of polishing machines.



**Fig. 5.10** *Technical terms in stone masonry*

### 5.3.2 Technical Terms

The technical terms in stone masonry are illustrated in Fig. 5.10.

**Natural bed** The surface on which the materials were originally deposited in the formation of rock is known as natural bed. Rocks, from which stones for masonry are obtained, have distinct planes of division along which stone can easily be split. These planes are the natural beds of the stone.

**Plinth** Plinth is the projecting course at the ground-floor level. It is used to indicate the height of ground-floor level from ground level. The plinth course protects the interior of a building from rain water, frost, etc.,

**Course** Course is a layer of stones (or bricks). The thickness of a course is equal to the thickness of a stone (or brick) plus the thickness of one mortar joint.

**String course** String course is a continuous horizontal course of masonry, provided at every floor level. This course remains projecting from the face of the wall. It is intended to improve the elevation of the structure.

**Lacing course** Lacing course is a horizontal course provided to strengthen a wall of regular small stones.

**Quoins** Quoins is the external coners or angle of a wall surface. The stone or brick used to form the quoin is known as quoin stone or quoin brick.

**Spalls** Spalls are stone chips broken off from large-sized stones during dressing and shaping.

**Bed joint** It is the horizontal joint between two consecutive courses of stone masonry.

**Corbel** Corbel is a stone piece provided in a wall. It projects partly outside. The projecting stone surface acts as bearing for the structural member such as beam, roof truss, wall plates, etc., resting on it.

**Pin header** Pin header is a long stone provided vertically in the stone masonry. It ensures a bond between successive courses.

**Cornice** Cornice is a moulded course of stone masonry. It is placed at the top of a wall or ceiling near the top of the building.

**Sill** Sill is the bottom surface of a door or a window opening.

**Coping** Coping is a course of stone, concrete or brick placed on the exposed top of parapet wall or compound wall. It protects the wall from seepage of rainwater through joints at the topmost course of the wall. A coping is suitable weathered and throated.

**Throating** Throating is a small groove cut on the underside of a sill, coping, cornice or sunshade. It is provided to discharge rainwater without trickling down to the walls.

**Weathering** Weathering is a slope provided to the top surface of stones used for coping, cornice and sill to drain off the water immediately.

**Through stone or bond stones** In stone masonry, some long stones at regular intervals are placed through the full thickness of a wall to develop bond. Such stones are known as through stones or bond stones.

**Jambs** Jambs are the vertical sides of the openings of masonry for doors, windows, etc. Jambs may be plain or splayed or may be provided with the recess to receive the frames of doors and windows.

**Reveals** Reveals are the exposed vertical surfaces left on the sides of an opening after the door or window frame is fitted in position.

**Hearting** Hearting is a filled-up core of a rubble wall.

**Lintels or heads** Lintels are the horizontal stones provided at the top of the openings for doors, windows, etc.

**Cramp** Cramp is a metal connection used in stone masonry construction.

### 5.3.3 Classification of Stone Masonry

[May, June 2013]

Stone masonry is classified based on the thickness of joints, continuity of courses and finish of face. The two broad classifications are given below:

- |   |  |
|---|--|
| <b>1. Rubble Masonry</b>                              | <b>2. Ashlar Masonry</b>                     |
| (i) Random rubble masonry<br>un-coursed and coursed   | (i) Ashlar fine masonry                      |
| (ii) Squared rubble masonry<br>un-coursed and coursed | (ii) Ashlar rough-tooled masonry             |
| (iii) Polygonal rubble masonry                        | (iii) Ashlar rock or quarry faced<br>masonry |
|   | (iv) Ashlar chamfered masonry                |
|   | (v) Ashlar facing masonry                    |

#### 1. Rubble Masonry

A rubble stone masonry wall is made up of irregular sizes and shapes. The stones obtained from the quarry are broken into small sizes and are directly used in the construction work.



In some cases, these stones may be shaped to suit the requirement, with the help of hammers just by removing excess projections. These stones have rounded natural face or angular faces or angular broken pieces.

Rubble masonry is further classified into three types. They are explained below.

- (i) **Random Rubble Masonry** Random rubble masonry uses stones of irregular shapes. The stones are arranged in a random fashion. The joints are pointed to achieve a good appearance. The efficiency of this type depends on the workmanship of the stone mason.

Random rubble masonry may be either uncoursed or coursed as explained below.

- (a) **Uncoursed Random Rubble Masonry** See Fig. 5.11(a). It is the cheapest type of stone masonry. Stone blocks are not dressed, but used in the masonry as obtained from the quarry. They are of varying sizes and placed in irregular pattern.

The vertical joints are not constructed in plumb. So, no regular courses are achieved. Larger stones are used at the bed level and in the corners. However, at 30 cm to 60 cm height intervals, the stones may be leveled.

Spaces between larger stones are filled with spalls (small stones of irregular sizes) and packed in mortar. Bond stones are used at random intervals. The appearance is not very pleasing.

Uses It is used for compound walls, godowns and walls of unimportant structures.

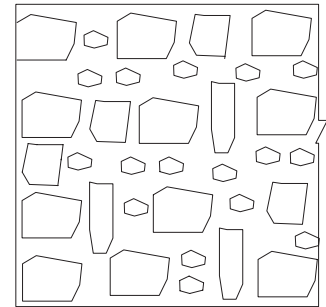


Fig. 5.11(a) Uncoursed random rubble masonry

- (b) **Coursed Random Rubble Masonry** See Fig. 5.11(b). In Coursed Random Rubble Masonry, stones of 5 to 20 cm size are used. Stones are hammer dressed.

Stones of equal height are used in every course of the stone masonry. Thus, masonry work is carried out in courses.

The stones are arranged such that the vertical joints of two adjacent courses do not coincide. Through Stones are used at every 2 meter distance in each course to form bond.

Uses: This type of masonry is used for residential buildings, industrial buildings, compound walls, warehouses, etc.

- (ii) **Squared Rubble Masonry** In squared rubble masonry, the stones are roughly squared with straight edges and sides with hammer blows.

- (a) **Un-coursed Square Rubble Masonry** See Fig. 5.11(c). In this type, the stones are of varying sizes of different heights, but with straight edges and

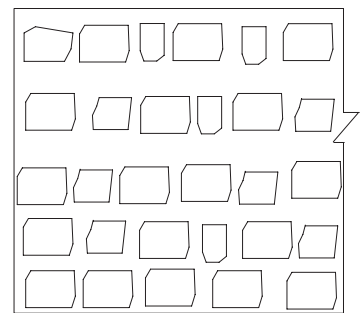


Fig. 5.11(b) Coursed random rubble masonry

sides. They are laid in irregular pattern. Hence, no regular courses are achieved.

A uniform joint is made in the facing of the masonry for better appearance.

(b) **Coursed squared Rubble Masonry**

See Fig. 5.11(d). This type of masonry also uses the same stones as used for uncoursed squared rubble. But, the work is carried out and leveled in courses of different heights.

Each course may consist of quoins, jamb and bonders.

- (iii) **Polygonal Rubble Masonry** In this type, the stones are hammer finished on the face of the wall to an irregular polygonal shape. These stones are bedded in position to show the face joints, running irregularly in all the directions.

## 2. Ashlar Masonry

In Ashlar Masonry, no irregular stones are used. The entire construction is done using square or rectangular dressed stone blocks of required dimensions. The beds, sides and faces of the stones used in this masonry are all dressed finely with chisel.

The height of stones varies from 25 to 30 cm. This masonry is laid in courses with thin end joints. It is the highest grade of masonry and costly. By arranging stones in various patterns, different types of appearance can be obtained. The backing of ashlar masonry may be built with stone rubble or brick masonry.

- (i) **Ashlar Fine Masonry** See Fig. 5.12. This type of ashlar masonry is very costly. In this masonry, all the stone blocks used should be finely chisel dressed on all the beds, sides and faces.

Height of each course is generally not less than 30 cm. Thickness of mortar joint should never be more than 3 mm. The face stones are laid as headers and stretchers

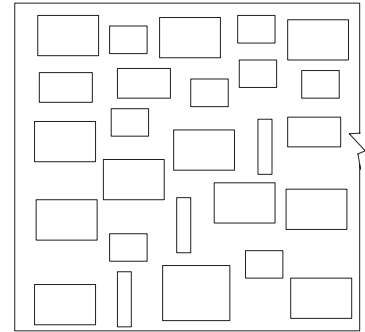


Fig. 5.11(c) Un-coursed squared rubble masonry

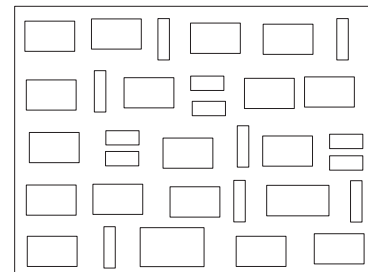


Fig. 5.11(d) Coursed squared rubble masonry

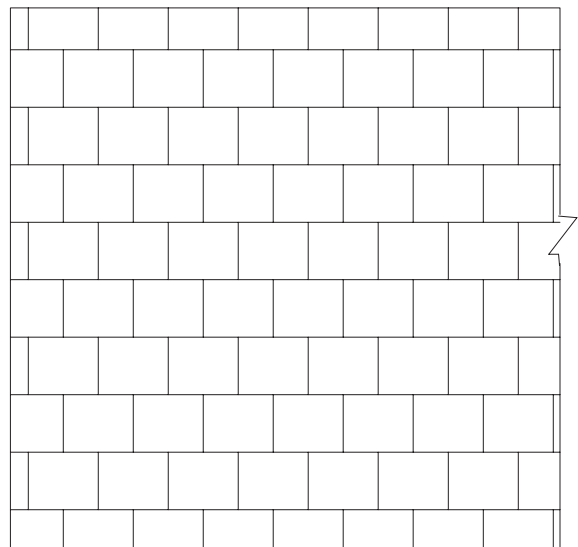


Fig. 5.12 Ashlar fine masonry

alternatively. For walls having thickness less than 75 cm. Through stones should be used at suitable intervals at each course for proper bond. This type of masonry gives perfect smooth appearance.

- (ii) **Ashlar Rough – Tooled Masonry** In this type of masonry, the beds and sides of each stone block are finely chisel dressed just in the same manner as for ashlar fine. But, the exposed face is dressed by rough tooling.

A strip about 25 mm wide and made by means of chisel is provided around the perimeter of the rough dressed face of each stone. The thickness of mortar should not be more than 6mm.

- (iii) **Ashlar Rock or Quarry Faced Masonry** In this type, a strip of 25 mm wide, made by means of a chisel is provided around the perimeter of the exposed face of each stone as in the case of rough-tooled masonry.

However, the remaining portion of the face of the stone is left in the same form as received from the quarry. It is not dressed. It is kept as such so as to give rock or quarry facing. Each stone block is maintained to its size with perfect straight sides, faces and beds and truly rectangular in shape. The thickness of mortar joint may be up to 10mm.

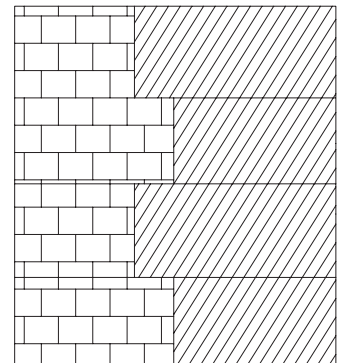
- (iv) **Ashlar Chamfered Masonry** This is a special form of rock-faced ashlar masonry. In this masonry, a strip provided around the perimeter of the exposed face is chamfered or beveled at an angle of  $45^\circ$  using the chisel to a depth of 25mm. Due to this, a groove is formed in between the adjacent blocks of stone.

Around this chamfered strip, another strip of 10 mm to 12 mm wide is dressed with the help of chisel. The space inside this strip is kept rock-faced, except the large projections that are removed by a hammer.

- (v) **Ashlar Facing Masonry** See Fig. 5.13. This masonry may be called as a combination of ashlar masonry and rubble masonry. In this type of masonry, only face work is provided with rough tooled or hammer dressed stones. Backing of the wall may be made in rubble masonry or brick masonry or concrete.

The beds and sides except exposed face are dressed perfectly fine and square. Thickness of joint does not exceed 6 mm.

Uses This type of construction is used for heavy engineering works such as retaining walls, sea walls, etc.



**Fig. 5.13** Ashlar facing masonry

- (vi) **Ashlar Block-in-Course Masonry** This type of masonry is an intermediate approach between the ashlar masonry and rubble masonry. It is constructed of large stone blocks. The faces of each stone block are hammer dressed. This masonry has regular courses. It is actually coursed rubble masonry of superior variety. The height of the blocks is kept the same in any course, though it is not necessary to keep uniform height for all the courses.

### 5.3.4 Points to be Observed while Supervising the Construction of Stone Masonry

1. The stones to be used should conform with the requirements of work.
2. The stones should be well watered so that absorption of water from mortar is prevented.
3. Stones are laid on their natural bed.
4. Stone work should be carried out in proper bond with sufficient number of through stones.
5. The mortar should be of good quality.
6. Stone work should be raised uniformly. If a cross wall is to be constructed later, steps should be provided in the wall.
7. Double scaffolding should be used to carry out stone work at a higher level.
8. The vertical faces must be checked with a plumb and inclined surfaces with wooden templates.
9. The stone work should be cured for 2-3 weeks if laid in lime mortar and for 1-2 weeks if cement mortar is used.

### 5.3.5 Principles of Stone Masonry Constructions [Apr, May 2015, Regulation 2008]

1. **Quality** Stones of stone masonry should be hard, strong, tough and durable.
2. **Dressing** Proper dressing of stones have to be done according to the type of masonry.
3. **Natural Bed** All the stones should be laid on the natural bed only.
4. **Mortar** Cement mortar or sometimes rich lime mortar in suitable proportion is used.
5. **Pressure Acting on the Stone** Stones in the stone masonry are laid such that the pressure acting on the stones is perpendicular to the natural bed of the stones.
6. **Tensile load** Stone masonry work should not be designed to take any tensile load.
7. **Watering** Stones should be watered before use to prevent water absorption from mortar.
8. **Course of stones** Different courses of stones laid perpendicular to the line of action of pressure on the stones.
9. **Through Stones** Through stones should be used sufficiently such that they cover about 15 to 25% of the area in elevation. This is to ensure proper bonding.
10. **Surface of Stone Masonry** Surfaces of stone masonry should always be kept wet while the work is in progress and also till the mortar has set.
11. **Vertical Joints** Extreme care has to be taken by providing proper bond to prevent formation of vertical joints. Vertical joints should be staggered.
12. **Lap between Bond Stones** Bond stones running to full thickness of walls should be used at regular intervals. For thicker walls, the minimum overlap between the bond stones should be 15 cm.
13. **Facing of Stone Masonry** Small stone pieces are used for facing of stone masonry.
14. **Hearting** Hearting of masonry should be properly packed with stone chips and mortar.

15. **Verticality** Verticality of faces of stone masonry walls are checked with a plumb Rule.
16. **Inclined Surfaces** Inclined surfaces should be checked with wooden templates.
17. **Unequal Settlement** Stone wall should be raised uniformly throughout its length. It will avoid possible unequal settlement.
18. **Future Work** If a cross wall is to be built later, steps should be provided in the wall.
19. **Void in Masonry** Voids in stone masonry should not be dry-packed or filled with small size aggregates. Instead, they should be well-packed with large aggregate and mortar.
20. **Stepped Raking** Unfinished end of stone masonry should be raked back. This stepped raking develops proper bond between the old and the new works.
21. **Curing** After the construction is over, the whole masonry work should be kept cured for two to four weeks.
22. **Double Scaffolding** Double scaffolding should be used to carry out stone work at a higher level of the structure.

**Table 5.1** Comparison of brick masonry with stone masonry

[May, June 2009; Nov, Dec 2011; Apr, May 2015]

Sl.No	Aspects	Brick Masonry	Stone Masonry
1.	Availability	Bricks are manufactured using clay	Stones are available in nature and obtained from quarries.
2.	Handling	Handling is easy	Handling is difficult
3.	Labour	Semi-skilled labour is needed	Skilled labour is necessary
4.	Strength	Reasonably good compressive strength	Very high compressive strength
5.	Durability	Reasonably durable and moderate long life	Highly durable and long lasting
6.	Maintaining the Bond	Made to regular size and shape. Due to this, proper bond can be maintained.	Stones require dressing for maintaining the bond.
7.	Quantity of Mortar required	Less	More
8.	Plastering	Plastering is needed	Plastering is not done.
9.	Moisture Absorption	Absorbs moisture from atmosphere	Stones are watertight
10.	Mortar Joint	Thin and uniform	Thick
11.	Wall Thickness	Thinner walls can be constructed	Difficult to construct walls of thickness less than 30 cm
12.	Openings and Connections	Construction of openings and connections are easy	Dressing of stones is required to achieve this
13.	Cost of Construction	Less	High

Contd.

Contd.

14.	Maintenance Cost	More	Less
15.	Architectural Treatment	Less Suited treatment	Amenable to architectural
16.	Fire Resistance	Highly Fire Resistant	Reasonably resistant to fire
17.	Dead Load	Dead load of walls is less	Dead Load is more
18.	Special Lifting Devices	Not Needed	Needed
19.	Appearance	Elegant appearance, used in residential, commercial buildings, etc.	Massive appearance, hence used for monumental works, temples, bridges, etc.

## 5.4 RCC STRUCTURAL MEMBERS

Nowadays, plain and RCC structural member like foundation, beams, columns, lintels, roofs, etc., are abundantly used in the construction of all types of buildings. This type of construction has withstood the test time. Its advantages are manifold. It is highly durable, strong, economical, quickness in construction, improved appearance, etc., Different types of finishes can be given to concrete.

### 5.4.1 Beams

Beams are horizontal members of a structure, carrying transverse loads. Beams carry the floor slab or the roof slab. They transfer all the loads (the dead load and live loads) including its self weight to the vertical members of the structures. The vertical members may be columns or walls supporting the beams. Ultimately, the loads from the columns or walls are transmitted to the foundation. From the foundation, the loads are safely transmitted to the sub-soil.

The RCC beam is subjected to bending moments and shear. Due to the vertical external load, bending compresses the top fibres of the beams and elongates the bottom fibres. The strength of an RCC beam depends on the composite action of concrete and steel. Since concrete is strong in compression and weak in tension, Reinforcing main steel bars are embedded in the tension zone to give the required tensile strength. Concrete takes all the compressive stresses and main steel bars take all the tensile stresses.

In addition to the main reinforcement, vertical shear bars called stirrups are provided to withstand shearing forces.

Beams may be termed simple beams when the end connections do not carry any end moments due to any continuity developed by the connection. A beam is continuous when it extends across more than two supports and is called a fixed beam if the ends are rigidly attached to other members so that a moment can be carried across the connection. Beams may be classified as follows.

*Girders* Main load carrying members into which floor beams or joists frame.

*Joists* Members used to carry roofing and floors of buildings.

*Lintels* Beam members used to carry wall loads over wall openings.

*Spandrels* Exterior beams at the floor level used to carry part of the floor load and the load due to exterior walls.

*Stringers* Members used in bridges parallel to the traffic to carry the deck slab and commonly frames into transverse members.

### 1. Floor Beams

These are the secondary members of a floor system in a building and the main members in bridge construction into which stringers frame. In most cases for maximising economy, a rolled steel shape is used so that the bending is about the strong axis. Beams can be of steel, concrete, timber or stone; generally, steel and concrete are used.

In case of the reinforced concrete beam, due to the vertical external load, bending compresses the top fibres of the beam and elongates the bottom fibres. Concrete being weak in tension needs to be strengthened to take up the tension induced in the bottom fibres. Hence steel rods are added to concrete at places where tension is induced thereby making the beam strong in compression as well as in tension.

Beam loading will consist of both dead and live loads. Where the span is small and the external load is light, the beam weight may be quite small. When heavy beams are used for large spans, their self-weight may be significant. In any case, the designed section should always be checked for adequacy for the applied loads, and the self-weight of the beam.

### 2. Types of Beams

Depending on the support, a beam may be of any one of the following types:

1. Simply supported beam
2. Fixed beam
3. Cantilever beam
4. Continuous beam
5. Overhanging beam

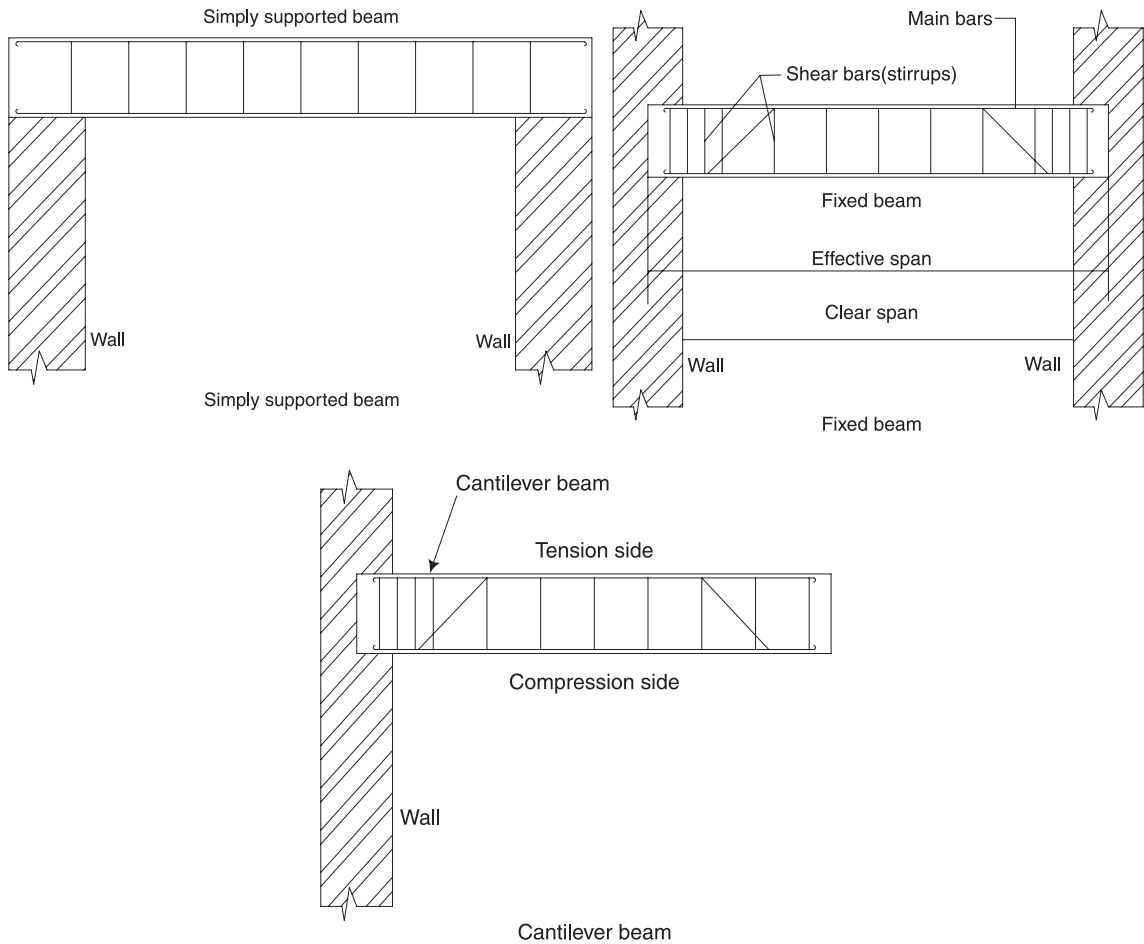
(i) *Simply Supported Beam* A beam supported freely at the two ends on walls or columns is called a simply supported beam. It is important to note that in actual practice, no beam rests freely on the supports (walls or columns) without fixing on the supports. Hence, no beam is practically simply supported. End connections (supports) do not carry any end moments due to the non-continuity developed by the connections of beam and supports.

(ii) *Fixed Beam* In a fixed beam, both the ends of the beams are rigidly fixed or embedded into the supports (walls or columns). Main reinforcement bars and shear bars (stirrups) are placed as in the case of simply supported beams.

Here, bending is constrained at the supports. A moment can be carried across the end connections.

(iii) *Cantilever beam* When a beam is fixed in a wall or column at one end and the other end is free, it is called a cantilever beam. This type of beam has tension zone in the top side and a compression zone in the bottom side.



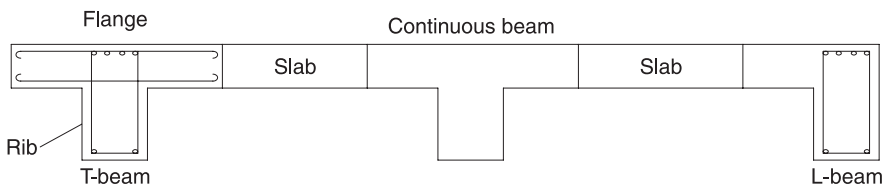


**Fig. 5.14** *Cantilever beam*

**Uses** Cantilever beams are used to support slabs projecting outside the wall or column. Examples are portico, balcony, etc.

*(iv) Continuous Beams*

A beam is said to be continuous beam when it is supported on more than two supports. This beam is more economical for any span lengths.



**Fig. 5.15** *Cantilever beam*

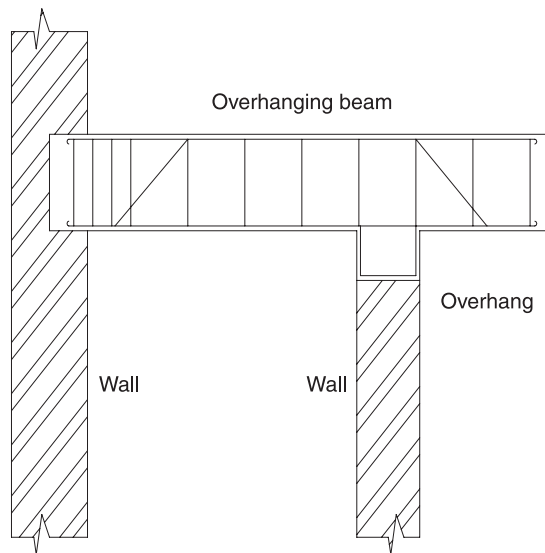


**T-Beam** As the name suggests, the section of this beam is in the shape of 'T'. The design concept of a T-beam is the monolithic action of the slab with the flange and rib portions of the beams. A T-beam is developed when a slab is cast monolithically with the beam and the slab extends on both the sides of the beams.

**L-Beam** An L-beam is developed when a slab extends on one side of the beam only and is monolithic. L-beams are used at the end walls of a room.

(v) *Overhanging Beam*

In an overhanging beam, its end extends beyond the wall or column support. The overhanging of the beam is the unsupported portion of the beam. It may be on side or both the sides of the support.



**Fig. 5.16** *Overhanging beam*

Depending on the reinforcement, a beam may be classified as follows:

(i) **Singly reinforcement beam**

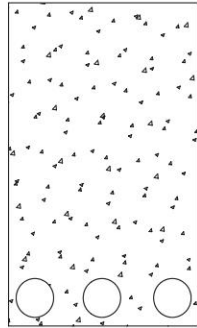
If the main reinforcement of steel bars are provided only on one side of the beam, it is known as singly reinforcement beam.

(ii) **Doubly reinforcement beam**

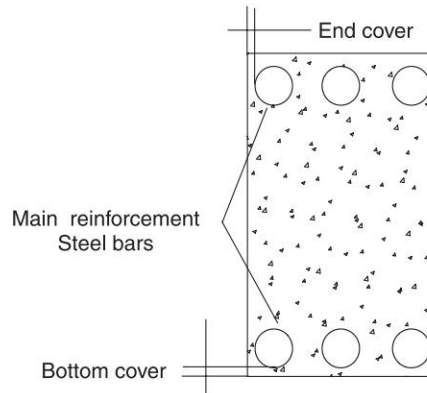
If the main reinforcement of steel bars is provided both at top and bottom (tension and compression zones) of the beam, it is known as a doubly reinforced beam. See Fig. 5.17(b).

**Concrete covers** Main bars are placed uniformly along the perimeter of the column leaving required covers. Concrete cover is the distance between the outer surface of the member and the nearest point of reinforcement.

**Bottom cover and End cover** The minimum bottom cover to be provided in the beam is 25 mm or the diameter of the bar, whichever is more. The end cover is 25 mm or twice the diameter of the bar, whichever is more.



**Fig. 5.17(a)** Singly reinforced beam



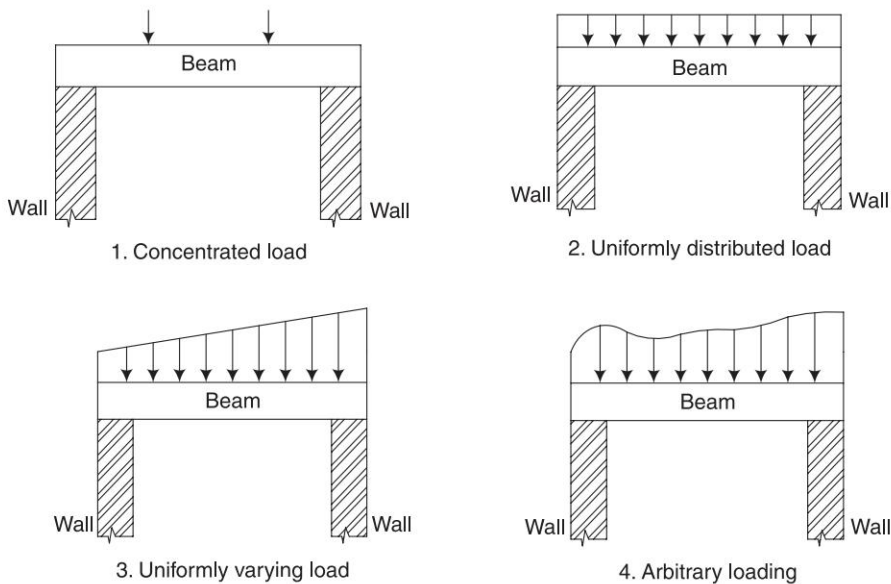
**Fig. 5.17(b)** Double reinforced beam

### **Types of Loading on Beams**

See Fig. 5.18(i), (ii), (iii) and (iv).

Loading on a beam may be different types. They are

- (i) Concentrated loads
- (ii) Uniformly distributed loads
- (iii) Uniformly varying loads
- (iv) Arbitrary loading



**Fig. 5.18** Types of loading on beam

### Steel Beams

Steel beams are generally rolled steel I-sections. I-sections with cover plates may be used when a large modulus of section is required. An I-section may be split and rejoined by welding and used for beams with large spans and light loads. Such a beam is more resistant to bending as the modulus of the section is increased.

An I-section along with a channel section is used when the beam is subjected to lateral loads at the compression flange level of the section.

## 5.5 COLUMNS

[May, June 2013]

A column is a vertical structural member. It transmits the load coming from the slab (ceiling/roof) and beam, including its self-weight to the foundation of the building. Columns may be subjected to a pure compressive load (axial compression) or a combination of compressive load and bending moment. A structural member subjected to an axial compressive load is known as strut.

Compression member in a truss may be known as chord members or web members, depending on their truss location. Columns may also be called by various other names, such as braces or struts.

### 5.5.1 Classification of Columns Based on Dimensions

Failure depends on the length of the member compared to its cross-sectional dimensions. Based on their length, the columns can be classified as long or short.

If  $\frac{l_{\text{eff}}}{a} \leq 12$ , it is a short column and

If  $\frac{l_{\text{eff}}}{a} > 12$ , it is designated as a long column

where

$l_{\text{eff}}$  is the effective length of column which depends on the conditions of the end support, and

$a$  is the least lateral dimension of the column or diameter of column in case of circular columns.

A short column is one in which the ultimate load at a given eccentricity is governed only by the strength of materials and the dimensions of the cross-section. A slender or long column is one in which the ultimate load is also influenced by slenderness, which produces additional bending because of transverse deformations. Thus we see, for short columns, the failure load is characterised by yielding and for long columns by buckling or instability. Members with lengths that fall between short and long columns are called intermediate columns. These fail by both yielding and buckling.

## 5.5.2 Classification Based on Materials of Construction and Shape

### 1. RCC Columns

If the effective length of a compression member is equal to or less than thrice the least lateral dimension, the member is made of plain cement concrete. If the effective length of a compression member is more than thrice the least lateral dimension, the member should be reinforced.

Reinforced concrete columns are of square, rectangular or circular cross sections. The load carrying capacity of the column depends on the strength of concrete and steel. If the percentage of steel used is less in a column, the steel will reach its yield strength prior to concrete. The column will not fail since it can take more load at this stage. Due to this increase in load, steel will yield and the concrete will reach its full strength. Hence, the strength of the entire material is utilised. On the other hand, if the percentage of steel used is large, then concrete fails first and the failure will be spontaneous.

**Uses** RCC columns are used in multi-storeyed buildings and heavily loaded structures. RCC columns are very widely used now-a-days.

### 2. Steel Columns or Stanchions

Steel columns are also known as stanchions. These are widely used in industrial structures. Steel columns are fabricated using rolled steel joists, channels, angles and plates.

A steel column is a vertical compression member. It supports or girders in a building. A girder is a main load carrying member into which floor beams or joists are connected. Joists are beam members, which are used to carry floors and roofs of buildings of light loads supported on long columns.

The shape of the cross section of the steel section and the sectional area should be designed carefully to avoid buckling. The important property required for a compression member is a high value of moment of inertia. I-sections, tubular sections and two equal-angle steel sections may be used for light loads. Single-angle sections should be avoided for steel columns.

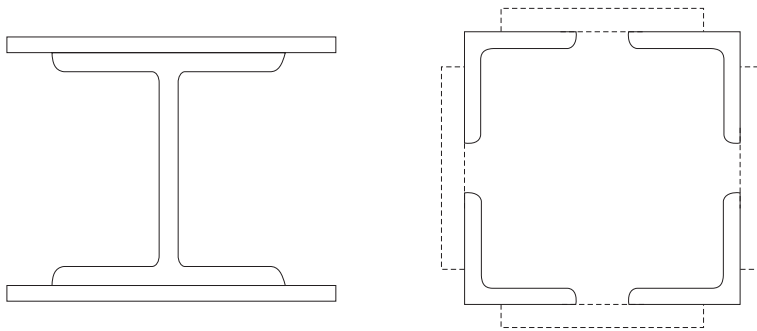
## 5.5.3 Built-Up Sections for Steel Columns

When two or three steel sections of rolled sheets and plates are connected to form a column, it is known as a built-up column or box column. See Fig. 5.19(a). Built-up sections are compression structural members with wide flanges. Hence, these are used for heavy loads. The type of built-up section to be used depends on the type of structure and the end connections of the columns.

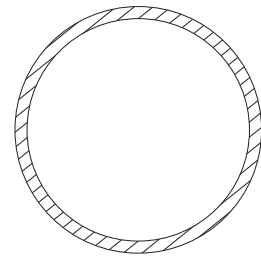
Steel compression members are pipes of circular, square or rectangular cross-sections and sections such as angles, channels, T or I-sections. These may also be built up of rolled sheets and plates. The kind of compression member to be used depends on the end connections and type of structure.

Built-up sections for commonly used compression members are shown in Fig. 5.18 (a). The pipe or round tubing shown in Fig. 5.19 (b) may be used for columns in one-storey warehouses, super markets and residential basements and garages. Wide-flange shapes are commonly used as building columns. Single channels can be used as compression members if intermediate bracing is provided in the weak direction. Angle and T-sections are used mainly as bracing members and compression members in trusses.

Columns can also be made of timber and masonry, which are not often used.



**Fig. 5.19** (a) Built-up sections for columns



**Fig. 5.19** (b) Column pipe

## 5.6 LINTELS

[May, June 2012]

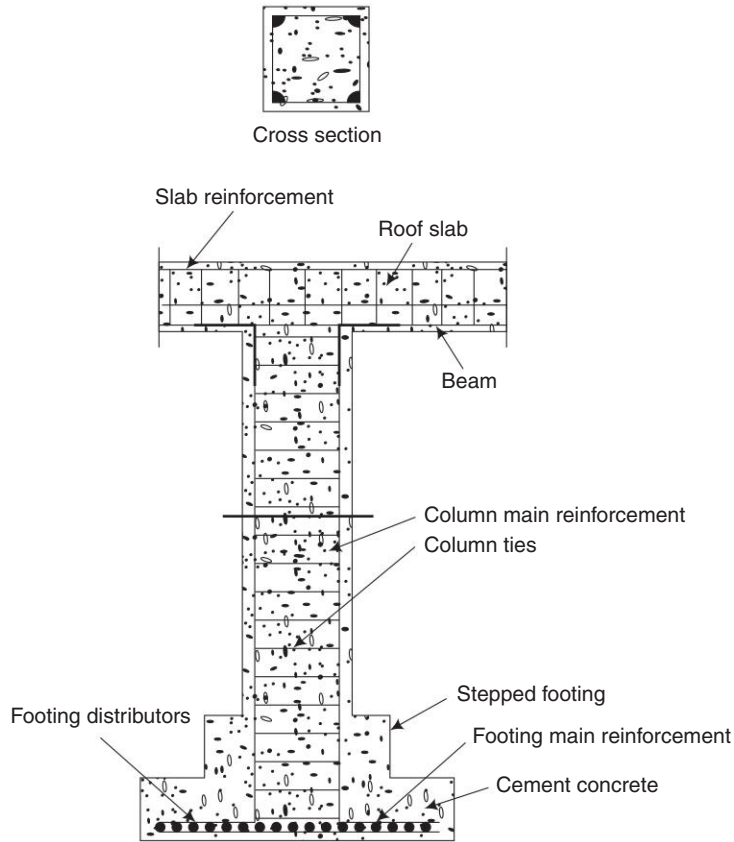
A lintel is a horizontal member which is placed across an opening to support the portion of the structure above it. The function of a lintel is same as that of a beam. Lintels may be of wood, steel, brick, stone and reinforced cement concrete. Each type is briefly explained in this section.

**1. Wood Lintel** A single piece of timber can be used as a lintel or three pieces bolted together along the thickness of the wall can be adopted. A bearing of 150–200 mm should be provided on the wall and it should be placed on mortar. The width is equal to the thickness of opening and depth should be about  $1/12$  to  $1/8$  of the span with a minimum of 80 mm.

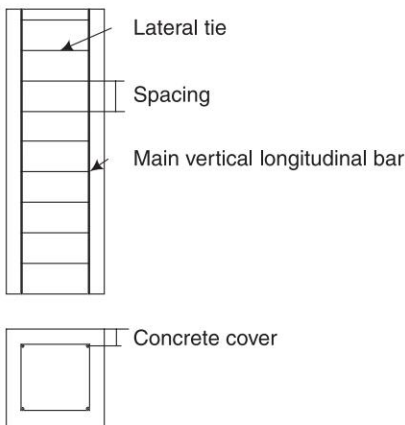
Wood lintels are liable to be destroyed by fire and decay. They are comparatively weak. Wood lintels help in securing heads of frames of timber doors and windows.

**2. Stone Lintel** Slabs of stones are placed across the openings. If stones are used as lintels, relieving arches are to be provided since stones have low tensile resistance. The depth of stone lintel should be at least one mm per one cm length of the opening. [May/June 2012]

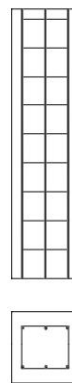
**3. Brick Lintel** A temporary wood support known as turning piece is used to construct a brick lintel. The depth of the lintel must be some multiple of brick courses. Brick lintel is weak and hence used up to 1 m span with light loading.



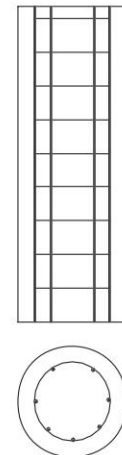
**Fig. 5.19** (c) Reinforced concrete column (Longitudinal section)



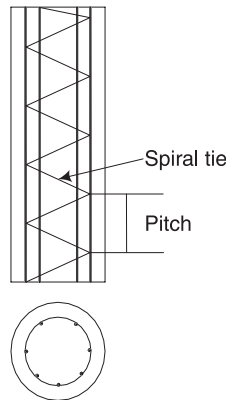
**Fig. 5.19** (d) Square RCC column (Square Tie)



**Fig. 5.19** (e) Rectangular column (Rectangular Tie)



**Fig. 5.19** (f) Circular column (Circular Tie)



**Fig. 5.19** (g) *Circular column (Spiral Tie)*

**4. Steel Lintel** This lintel consists of steel angles or rolled steel joists. The former is used for small spans and the latter for large spans. Tube separators are provided to keep the joists in position. Joists are embedded in concrete to protect steel from corrosion and fire.

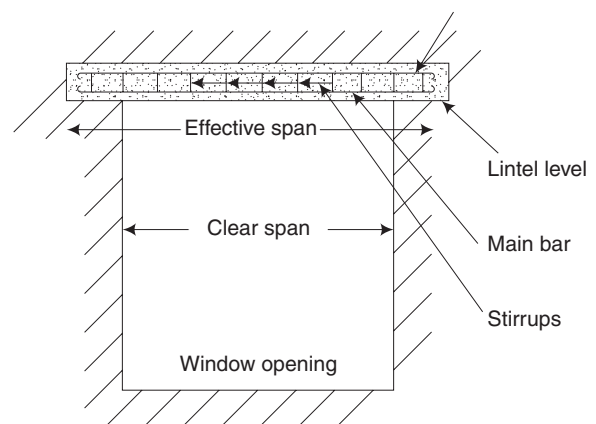
[May, June 2012]

**5. Reinforced Cement Concrete Lintel** RCC has replaced practically all other materials for lintel. RCC lintels are fire-proof, durable, strong and easy to construct. The usual concrete mix used for lintel is 1:2:4. Plain concrete lintels can be used up to a span of 800 mm. The amount of reinforcement depends upon the span.

[May, June 2012]

RCC lintels can be precast or cast-in-situ. Precast RCC lintels are convenient for spans up to 2 m. Also, they increase the speed of construction and allow sufficient time for curing before fixing. The top of the lintel should be properly marked with tar or paint so that the lintel can be placed correctly. For cast-in-situ RCC lintels, centering is prepared, reinforcement is placed and concreting is done. Sunshades can be easily projected from the lintels.

Where appearance is not important, the surface of RCC lintel is left exposed. Figure 5.20 shows a lintel over a wall. Flexible DPC must be provided and the toe of the lintel should be strong enough to bear the load of wall above it.



**Fig. 5.20** *Reinforced concrete lintel*

## 5.7 ROOFING

[Nov, Dec 2010; May, June 2011]

A roof is the uppermost part of a building which is supported on structural members and covered with roofing materials to give protection to the building against rain, wind, heat, snow, etc.

A good roof is just as essential as a safe foundation. A roof must be designed and constructed to meet the requirements of different climates and the covering materials available. A roof should be durable and stable, strong enough to take the loads coming on it, be well drained and waterproof.

### 5.7.1 Types of Roofs

The roofs are classified according to shape, span and structural design principles as follows:

- |                            |                 |                         |                  |
|----------------------------|-----------------|-------------------------|------------------|
| 1. Flat roofs              | (a) RCC roof    | (b) Madras terrace roof |                  |
| 2. Sloping or pitched roof | (a) Single roof | (b) Double roof         | (c) Trussed roof |
| 3. Curved roofs            | (a) Shell roof  | (b) Dome roof           |                  |

### 5.7.2 Flat Roofs

Flat roofs are used in buildings of any shape. They are economical too. They are suitable for buildings in plains or in hot regions, where rainfall is moderate and where there is no snowfall.

Flat roofs are two types, namely, RCC roofs and Madras terrace roof.

#### **RCC Roofs**

[Nov, Dec 2010; May, June 2011]

An RCC roof is commonly and most widely used. In this roof, concrete with steel reinforcement bars is used to form a flat roof.

An RCC roof consists of an RCC slab, built monolithically with the supporting columns. The slab is reinforced in both the principal directions. Load is carried by the slab, which is directly supported by the columns.

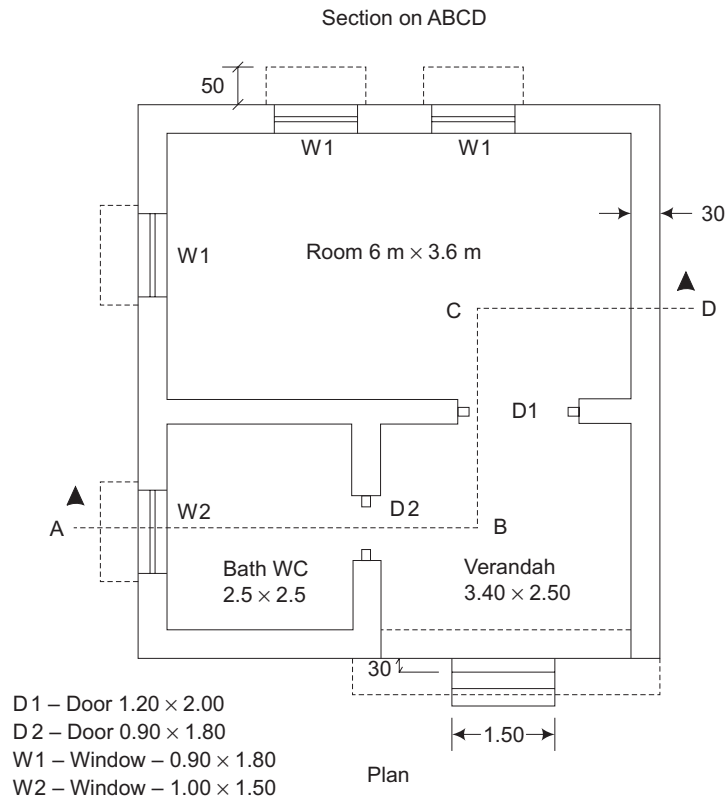
The thickness of the roof slab depends on the span and loading conditions. (An RCC beam may also be provided to support the slab. The thickness of the roof slab, beam and reinforcement are designed based on the roof and the loading conditions.) The roof-slab thickness may be 80 to 150 mm.

Columns are provided with enlarged heads known as column heads. To support heavy loads, the thickness of the slab over the columns may be increased. The thickened part of the slab is called a drop panel.

#### **Damp Proof Course**

It prevents entry of moisture (dampness) due to a leaking roof. Weathering course or weathering-proof course is provided on the top of an RCC roof to prevent the roof from the weathering agencies like sun, rain, wind, and snow. Also, it minimizes the heat radiation into the room below the roof.





**Fig. 5.21** A section of a RCC roof

**Surki** concrete (broken brick aggregate and lime) is laid on the roof and completed well. The thickness of the weathering course is 75 mm. It is given with a slope of 10 (1 in 50 slope), directed towards the rainwater drain pipes.

After curing for 6 days, two courses of flat tiles or one course of pressed tiles may be laid in a cement mortar ratio of 1:3 mixed with crude oil.

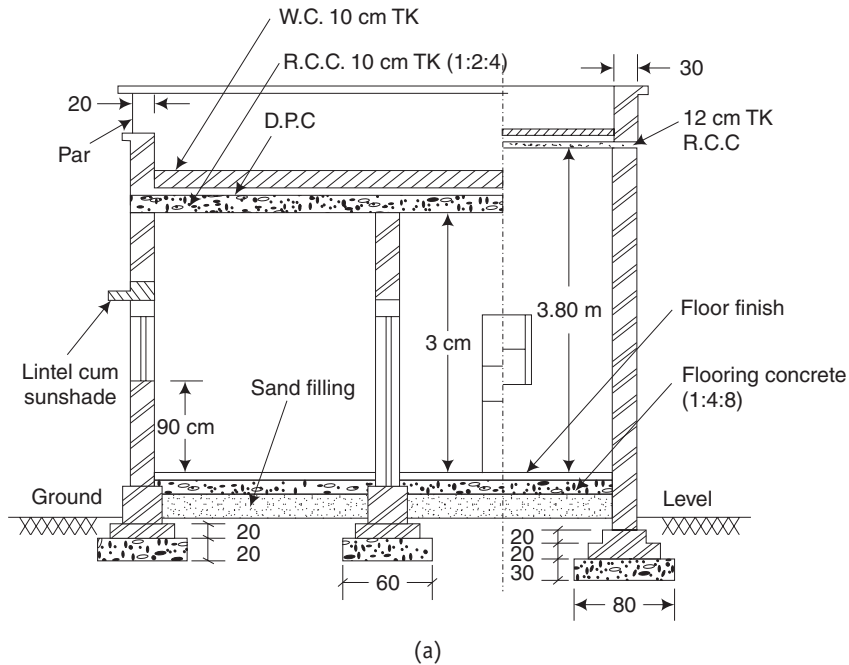
#### **Construction of Flat RCC Roof Details**

**Centering** Centering sheets or planks are arranged horizontally at the top levels of wall over the wooden or steel supports.

**Grid of steel bar** Main reinforcement mild steel bars of diameter 9 mm to 18 mm are tied in the form of grid of the centering sheets as per design.

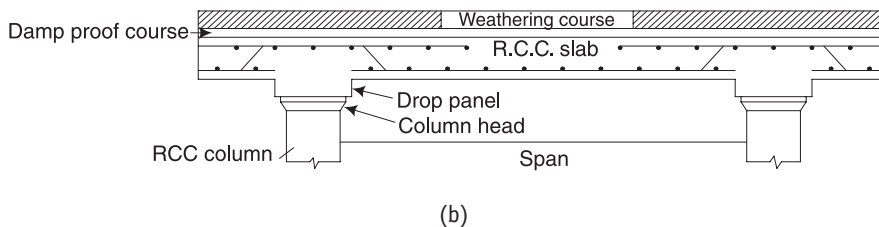
**Cover** RCC slab bends downwards, causing tension at the bottom fibers. Hence, steel bars are placed at the bottom of slab, keeping a minimum clear cover of 15 mm between the bars and centering sheets.

**Mixing cement concrete** Cement concrete of 1: 2: 4 mix is mixed thoroughly with sufficient quantity of water manually or in concrete mixer and placed on the centering sheets.



**Fig. 5.22(a)** *RCC roof on the wall*

[Nov, Dec 2000, 2009]



**Fig. 5.22(b)** *RCC roof on columns*

**Compaction of the concrete** The concrete is compacted well manually or by using mechanical vibrator to the required thickness and the top surface is levelled.

**Slope of the roof** Surface of the roof at the top of the building is given a gentle slope up to  $10^\circ$  for draining-off rain water easily and rapidly.

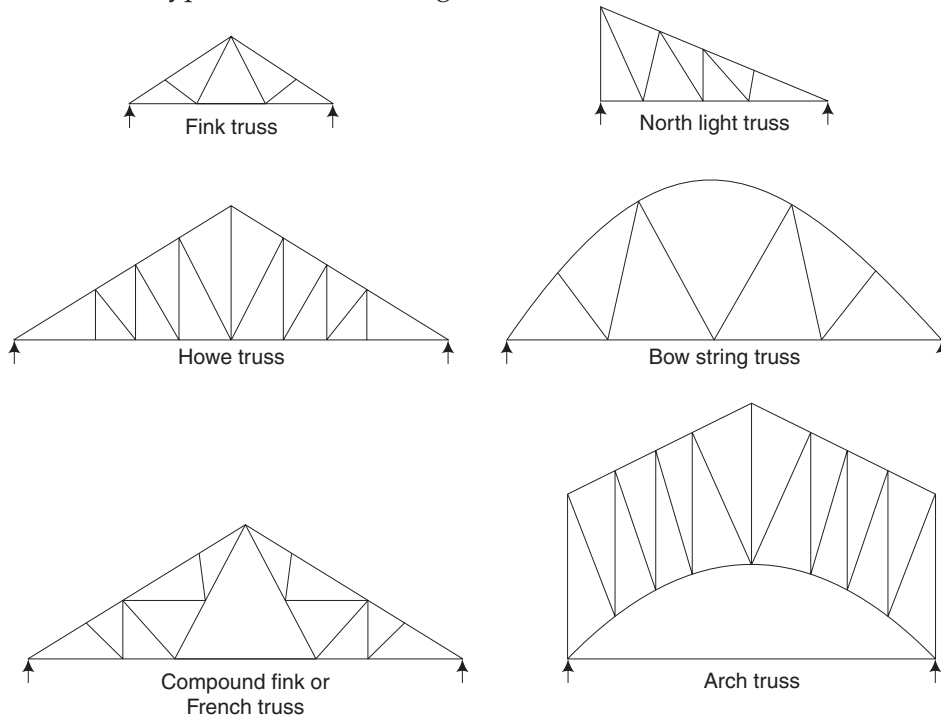
**Curing** Curing is carried out for one or two weeks to facilitate continued hydration of cement.

**Long spans and T-beam slab** For long spans a 'T' beam is developed by casting the roof slab monolithically with the beam and the slab

### 5.7.3 Steel Roof Trusses – Sloping Roof

Truss is a pin-jointed frame made of axially loaded members. Steel trusses are used for pitched roofs especially in industrial buildings. Steel trusses are normally adopted

for spans greater than 12 m. Concrete trusses are rarely adopted since these are weak in tension. Steel trusses are less massive when compared to concrete but need frequent maintenance as they are liable to be rusted. They must be painted with anti-corrosive paints. Steel trusses are adopted in bridges also. There are various types of trusses out of which the common types are shown in Fig. 5.23.



**Fig. 5.23** Various forms of trusses

A sloping roof has a top sloping surface known as a pitched roof. Sloping roof or pitched roof is commonly used at places of coastal regions of heavy rain fall and snow fall. These are comparatively light in weight. Shapes of sloping roofs depend on the area to be covered, material used, light and ventilation needed, etc.

### 1. Terminology

- (i) **Span** Span is the distance between the supports of a roof or truss.
- (ii) **Pitch** Pitch is the inclination of the sides of a roof to the horizontal
- (iii) **Rafter** Rafter is an inclined wooden member running from the ridge to eave.
- (iv) **Wall plate** Wall plate is placed at the top of the walls to support the rafter.
- (v) **Eave board** It is fixed along the eave joining the pair of rafters.
- (vi) **Ridge piece** Ridge piece is a horizontal member, running along the length of the roof.
- (vii) **Battens** Battens are small sections of the timber fixed to the rafters for placing the roofing material on the sloping roof.

- (viii) **Purlins** Purlins are horizontal members kept over the tie beam to support the rafters.
- (ix) **Truss** Truss is a frame work of triangles, used to carry the load of the roof-covering materials and other members of the roof.

## 2. Sloping Roofs are Classified as

- Single roof
- Double or Purlin roof
- Trussed roof

### (i) Single Roof

Single roofs consist of only common rafters, supporting the roofing material. Rafters are supported at the wall plates and rigid pieces. Single roofs are used for spans up to 5m, so that no intermediate support is required for the rafters.

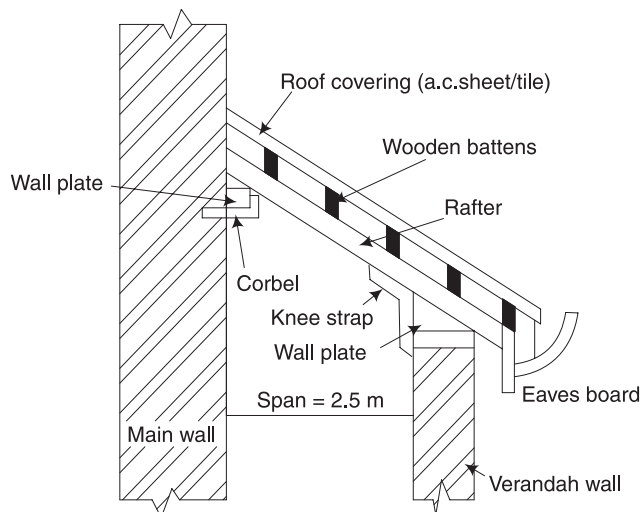
The varieties of single roofs are (a) lean-to-roof, (b) coupled roof, (c) coupled close roof, and (d) collar roof.

#### (a) Lean-To-Roof

See Fig. 5.24. A lean-to-roof is the simplest type of sloping roof. It is used for verandahs, car sheds, out-houses, etc., attached to the main buildings. This roof projects from the main wall of the building. Its span is limited to 2.5 m only.

Common rafters are provided at an angle of about  $30^\circ$  to the horizontal. These are kept at uniform intervals along the length of the roof. These are secured on the wall plates at both the ends. The upper wall plate rests on stone or steel corbel on the main wall.

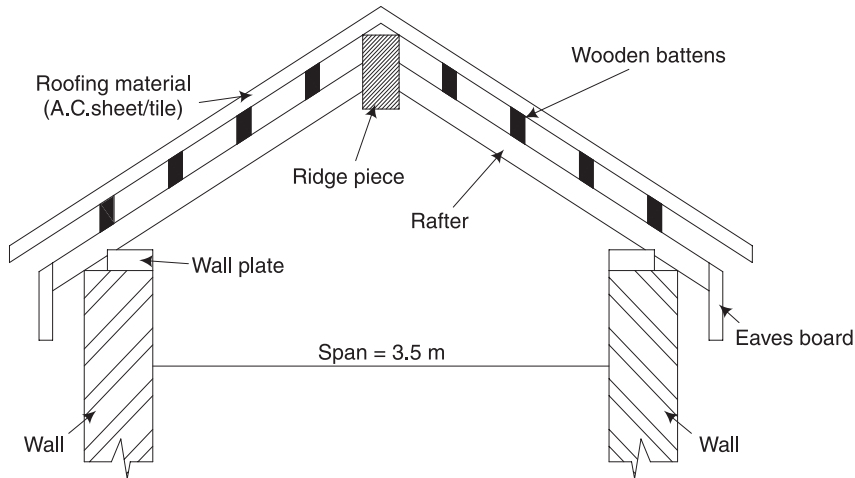
Battens (wooden) are fixed to the rafter. Roof coverings are fixed to the battens as shown. Roof coverings may be AC sheets or tiles.



**Fig. 5.24** Lean-to roof

## (b) Coupled roof

See Fig. 5.25. In a coupled roof, a pair or coupled of rafters slope upwards from the walls. The rafters are kept at uniform intervals along the length of the roof. The rafters are connected at the upper end to a longitudinal beam called the ridge piece. The ridge piece is running along the length of the roof.



**Fig. 5.25** Coupled roof

The rafters are nailed to wall plates at the lower ends. The wall plates are fixed on the supporting walls. The roofing materials such as AC sheets or Tiles are supported on battens, which are fixed to the rafters. Coupled roof is suitable for spans up to 3.5 m. It is not favoured, as the rafters have a tendency to spread out at the lower ends and thrust out of the wall.

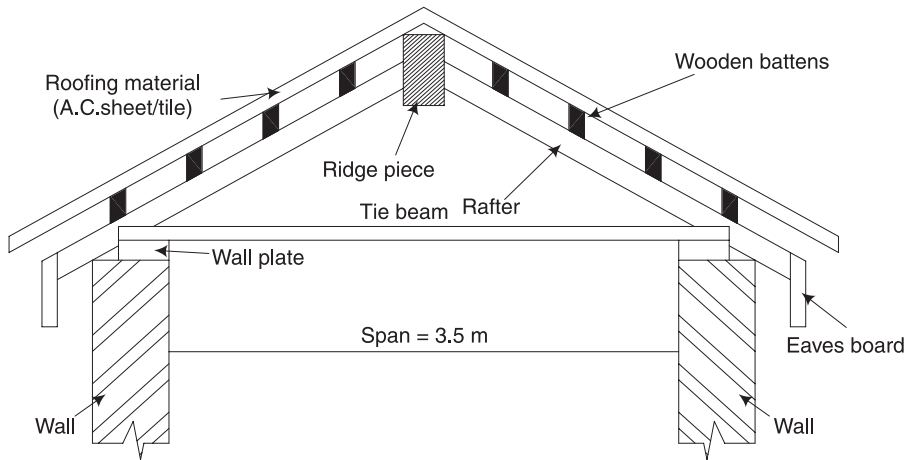
## (c) Coupled close roof

See Fig. 5.26. This is similar to the coupled roof except that, the lower ends of the rafters are connected to a tie beam at the bottom. There is a tie beam for each pair of rafters.

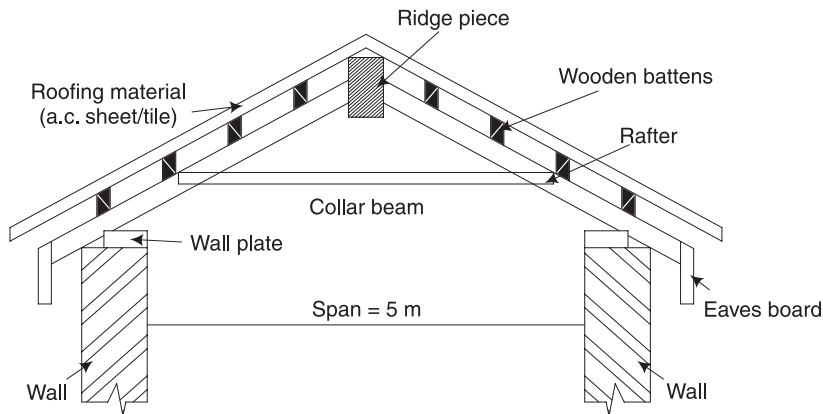
When the length of the rafters becomes larger, the rafters will have a tendency to spread out and thrust out of the walls. The tendency of spreading out of rafters can be arrested with the tie beam. Such a roof is called a coupled close roof. A coupled close roof is suitable for spans up to 4.5 metres.

## (d) Collar beam roof

See Fig. 5.27. This is similar to the coupled close roof. The only difference is that the tie beam is fixed at a height of  $1/2$  to  $1/3$  of the vertical height between the wall and the ridge piece. This raised beam is called a collar beam.



**Fig. 5.26** *Coupled close roof*



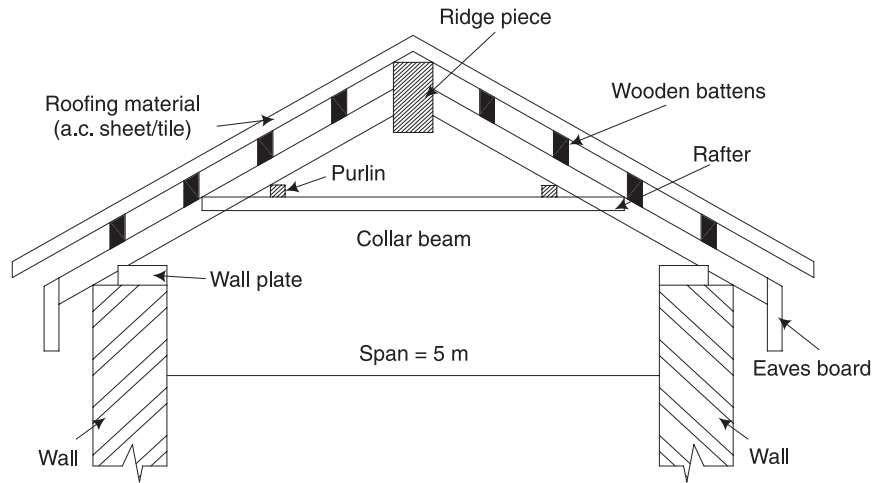
**Fig. 5.27** *Coupled tie roof*

The tie beam is raised to prevent the coupled close roof from bending due to increase in span or increase in load. This roof is suitable for spans of up to 5 metres.

### (ii) Double or purlin roof

See Fig. 5.28. In this type, additional members called purlins are provided at intermediate points. Purlins support the common rafters. The size of rafters can be reduced by the use of purlins. Purlins rest on the collar beam.

This roof is suitable for spans of up to 5.5 metres. Each rafter is supported at four points, namely, (i) at the bottom on the wall, (ii) at the top by the ridge piece, (iii) at the centre by the collar beam, and (iv) at the intermediate supports by purlins.



**Fig. 5.28** *Double or purlin roof*

### (iii) Trussed roofs

A number of straight members connected in the shape of triangle and forming a frame is known as *truss*. Trusses are wooden-framed structures, provided where there are no inside walls to support the purlins.

Trusses are provided at regular intervals of about 3 meters along the room length. The spacing of trusses depends upon the load on the roof, position of cross walls, span and material of the truss.

Ends of purlins are supported by the trusses. The purlins provide intermediate support to the common rafters, which in turn support the roof coverings. Trussed roofs are used for spans exceeding 5 metres.

### 5.7.4 Definitions

- (i) **Ties** Tension carrying members in the truss are called ties.
- (ii) **Struts** Compression members in the truss are called struts.
- (iii) **Span** The distance between the supporting ends of a truss is called its span.
- (iv) **Rise** The rise of the truss is the vertical distance between the apex and the line joining the supports.
- (v) **Pitch** The ratio of the rise to the span is called the pitch.
- (vi) **Purlins** Purlins provide intermediate support to the common rafters.

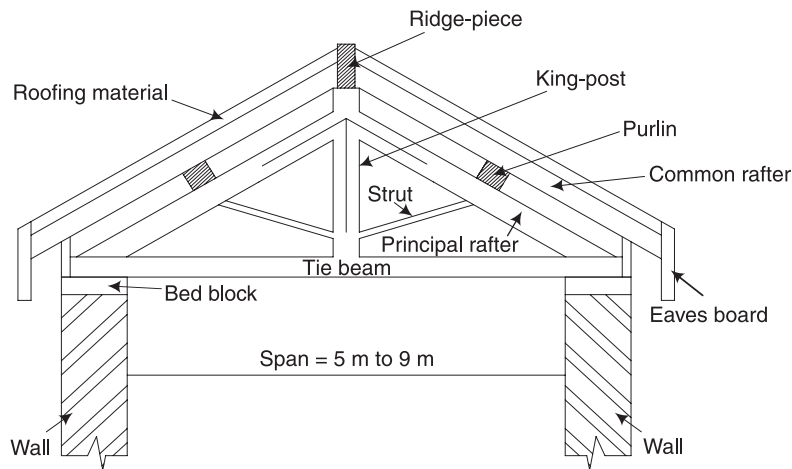
The common types of trussed roofs are

- (a) *King-post truss*
- (b) *Queen-post truss*
- (c) *Steel-roof truss*

**(a) King-post truss**

See Fig. 5.29. A king-post truss is a timber truss. It consists of a king post at the centre, two inclined struts, two inclined principal rafters and a tie beam at the bottom. The vertical central post which connects the ridge piece with the tie beam is known as the king-post truss.

The truss rests on a bed block of stone or concrete at either end. The bed blocks rest on walls. The roofing material is supported on common rafters. The common rafters are supported on wooden purlins provided at suitable intervals. Purlins are supported by the principal rafters. The king post connects the ridge piece and the middle of the tie beam.



**Fig. 5.29** *King-post truss*

The struts are connected to the king post at the bottom and the principal rafters at the top. Struts prevent the principal rafters from bending at the centre. The roofing material is fixed to the common rafters. These are used for spans in the range of 5 – 9 metres. It is usually built of wood completely or of wood combined with steel. Steel rods are used as tension members.

**(b) Queen-post truss**

A queen-post truss is used for spans from 9 – 12 metres. It is also a timber truss. It consists of two queen posts instead of one as in king post truss.

**(c) Steel roof truss**

Timber trusses become very heavy and costly, when the span exceeds 10 metres. Mild steel is readily available in rolled sections of standard shapes and sizes, namely, angles, channel sections, T-sections, I-sections, etc. Steel roof trusses are mostly fabricated from angle sections. The reason is that they can resist both tension and compression effectively.

Steel-roof trusses are frames formed by a number of straight members, made of steel angles. These members are connected in the shape of triangles. The members are jointed together by welding or riveting. External loads act at these joints of the members. The



shape and positioning of members in a steel truss are designed such that the members are subjected to either tension or compression. The compression members are called struts and should be short to avoid buckling. The tension members are known as ties. Trusses do not have any bending stresses in them.

The principal rafter and the main ties are generally made of two angle sections placed side by side. The struts and ties are generally made of single angle section.

#### **Advantages of steel roof trusses**

1. Steel trusses are more rigid and stronger than wooden trusses.
2. Members of the steel trusses are equally strong in both tension and compression.
3. They can be used over any span length ranging from 4.5 meters to very large spans up to 30 metres.
4. They are easy to fabricate from rolled steel sections, which are readily available in the required dimensions.
5. They are more economical compared to timber trusses.
6. Steel trusses are permanent structures with durability of a very long life.
7. Steel trusses are more resistant to environmental/ atmospheric agencies.
8. They are fire resistant unlike timber.
9. They are termite-proof unlike timber.
10. They can be easily installed.

#### **Disadvantages of steel roof trusses**

Steel roof trusses are likely to get rusted. They must be painted with anti-corrosive paints. Hence, steel trusses need periodical maintenance.

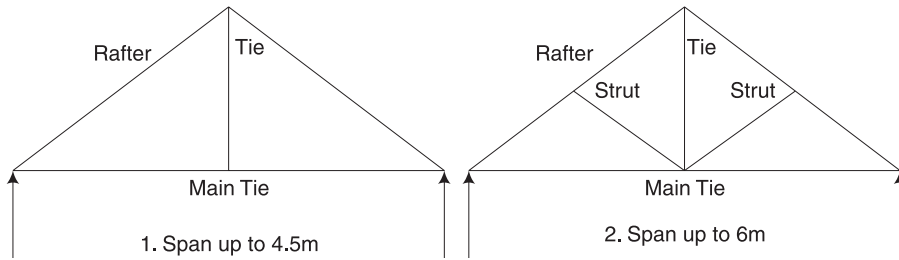
#### *Uses*

1. In construction of buildings of large spans such as educational institutions, industries, auditoriums, theatres, godowns, warehouses, garages, etc., including bridges.
2. No intermediate columns in the above type of buildings and availability of a clear and un-obstructed working space.
3. Places of heavy rain fall or snow fall.

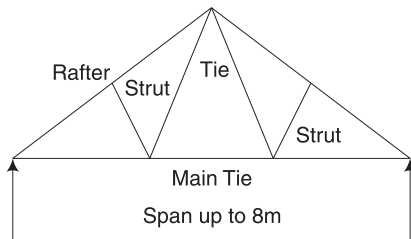
#### **Types of steel roof trusses**

The type, size, and relative positions of members of a steel roof truss are based on the span, roof slope, load coming over the roof, roof covering material and centre to centre of the truss.

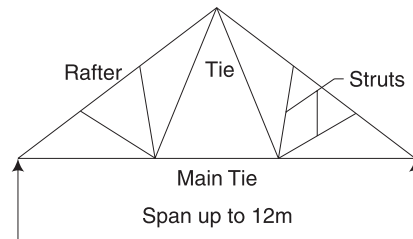
1. King post steel truss See Fig. 5.30. The relative positions of the members of the truss, namely, main tie, rafters and struts are shown. The steel truss shown in Fig. (1) can be used for spans up to 4.5 metres. The steel truss shown in Fig. (2) can be used for spans up to 6 meters.
2. Simple fink steel truss See Fig. 5.31. Fink-type truss is found to be very satisfactory for ordinary buildings. These trusses are used for spans up to 8 metres.



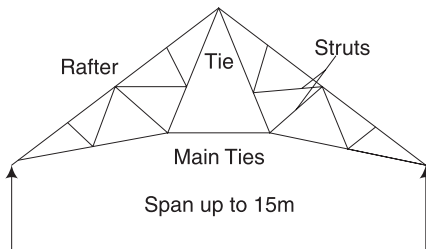
**Fig. 5.30** *King-post steel truss*



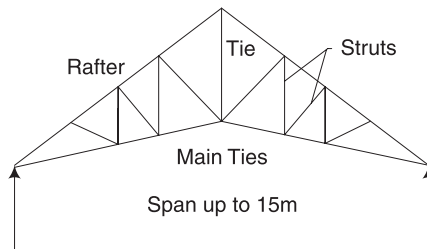
**Fig. 5.31** *Compound fink steel truss*



**Fig. 5.32** *Compound Howe's steel truss*

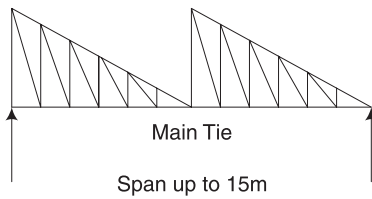


**Fig. 5.33** *Compound fink steel truss*

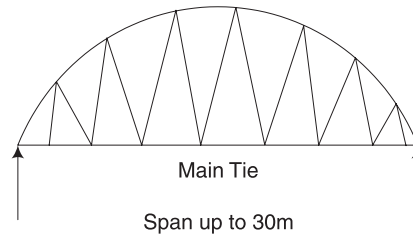


**Fig. 5.34** *Compound Howe's steel truss*

3. Simple Howe's steel truss These trusses are used for spans of up to 12 metres.
4. Compound fink steel truss or french truss These trusses are used for spans up to 15 meters. This type truss is also known as French truss.
5. Compound Howe's steel truss See Fig. 3.35. These trusses are also used for spans up to 15 metres. In this truss, the diagonals are in compression and the verticals are in tension under dead load.
6. North light steel truss See Fig. 5.36. These trusses are used for spans up to 15 metres. This type of truss is used for industrial buildings to obtain adequate natural lighting for a wide building.  
In this, the steep sides of the truss are glazed. The glazed panel is faced towards north to avoid direct sunlight and direct glaring of the sun. This type of truss is also known as saw tooth.
7. Bowstring steel truss These trusses are used for spans of up to 30 metres.



**Fig. 5.35** *North light steel truss*



**Fig. 5.36** *Bowstring steel truss*

### 5.7.5 Roof Coverings for Pitched Roofs

The selection of proper roof covering depends on the climate of the locality, nature of the building, cost of the roof coverings and resistance to fire and heat. Some of the commonly used roof coverings are discussed below:

**Thatch** Thatch is very light and is the cheapest form of roof covering. It is combustible, absorbs moisture and is liable to decay. Thatch is used in rural areas at a pitch of  $45^\circ$  to have proper drainage.

**Half-round tiles** These are used for cheap buildings. If tiles are laid in two layers, it is known as double tiled roof. An overlap of at least 80 mm should be provided for these tiles. These are brittle and hence require frequent replacement.

**Shingles** Wood shingles are obtained from timber with length varying from 300–380 mm and width of 60–250 mm. They are laid in the same manner as tiles and are useful in hilly areas where wood is cheap.

**Patent tiles** Mangalore tiles are one of the patent tiles. They are red in colour and special tiles are available for ridge. It is found that about 15 tiles are required to cover  $1 \text{ m}^2$  of roof area.

**Trafford asbestos cement tiles** These are made up of cement and asbestos. They possess less corrugations and are laid with laps of 150 mm at the ends and 100 mm at the sides.

**Eternit slates** These are fire resistant, light and cool. They are not easily affected by weather. About 8 slates are required for covering  $1 \text{ m}^2$  of roof area. Eternit slates are available in grey, black and red colours.

**Corrugated galvanised iron sheets** These are used as roof covering for factories, sheds, cheap buildings etc. They may be covered with country tiles so as to keep the interior side of the building cool. Sheets are laid with the corrugations running down the slope of the roof. Laps of 15 cm are to be provided at the ends. These sheets are light in weight and are easy to fix.

**Asbestos–cement corrugated sheets** These sheets can be cut, nailed, sawn or screwed and they are light, non-absorptive, strong and tough. These sheets can withstand extreme variation of temperature.

**Ruberoid** This is a light, flexible and waterproof material. This is not affected by atmospheric agents and white ants. These are available in red and grey colours. Its weight varies from 10–20 N/m<sup>2</sup> and it is available in rolls.

### 5.7.6 Weatherproof Course

Weatherproof course is also known as weathering course. Weathering course is a layer provided on the top of RCC or Madras terrace roof to protect the roof from the weathering agencies like rain, wind, sun and snow. Weathering course prevents entry of rain water into the roof slab or terrace. It also arrests the penetration of heat into the room below the roof.

Weathering course consists of lime concrete with broken brick aggregate and two courses of flat tiles set in cement mortar 1:3 mixed with crude oil. Lime concrete has a proportion of 1:2.5 (lime:broken brick aggregate). Lime concrete is laid to a thickness of 100 mm and compacted to a thickness of 75 mm. A minimum slope of 1 in 50 is given to the lime concrete layer towards the rainwater drainage pipes.

After the concrete is cured, by sprinkling water for six days, two courses of flat tiles are laid in cement mortar 1:3 with crude oil.

#### **Methods of Weather Proofing in RCC Slab Roofs**

1. In the case of RCC slab roofs, to prevent the entry of rain water, a 10 cm thick brick-bats lime concrete (1:2:4) or brick-bats cement concrete (1:8:14) terracing is provided over the roof slab as shown in Fig. 5.37.

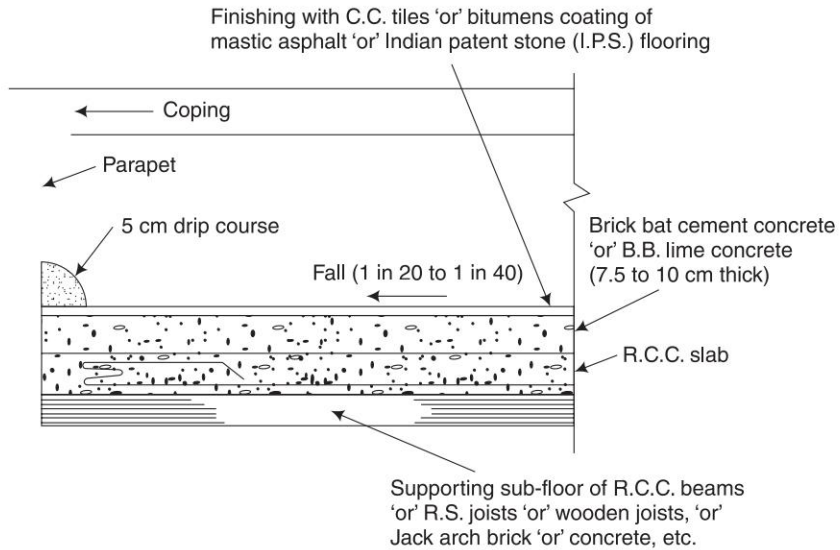
Over this concrete terracing, a suitable flooring such as CC tiles, terrazo, China mosaic, Indian patent stone, etc. is laid. This technique of weather proofing is illustrated in Fig. 5.37. A good fall or slope to the surface from 1 in 20 to 1 in 40, depending upon the intensity of rainfall should be given.

2. An alternative technique of weather proofing the RCC flat roofs is by using plastic transparent films, as shown in Fig. 5.38. These films of alkathene or Polythene are available in thicknesses from 100 to 700 gauge in rolls of 1.8 m width.
3. Another technique of weather proofing the flat roofs, made of wooden battens, RCC joists or Jack arches, etc. is illustrated in Fig. 5.39. The details of different layers, connecting the clay tiles, cement plaster, tar-felt mudplasters with clayey earth in between bitumen coats, are explained in Fig. 5.39.

## 5.8 FLOORING

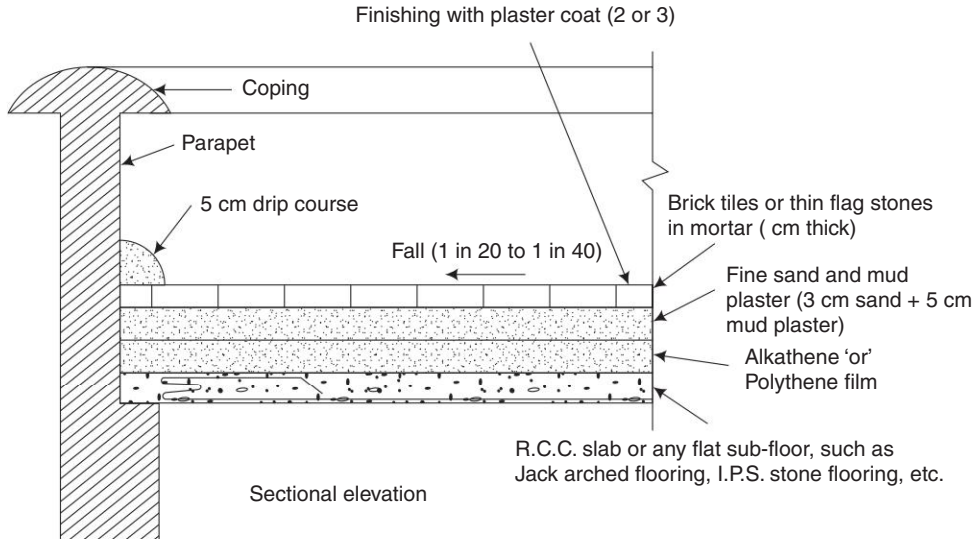
Floors are the horizontal elements of a building structure which divide the building into different levels for the purpose of creating more accommodation within a limited space. The floor consists of the following two components:

1. **A subfloor (or base course)** The purpose of this component is to impart strength and stability to support floor covering and all other superimposed loads.



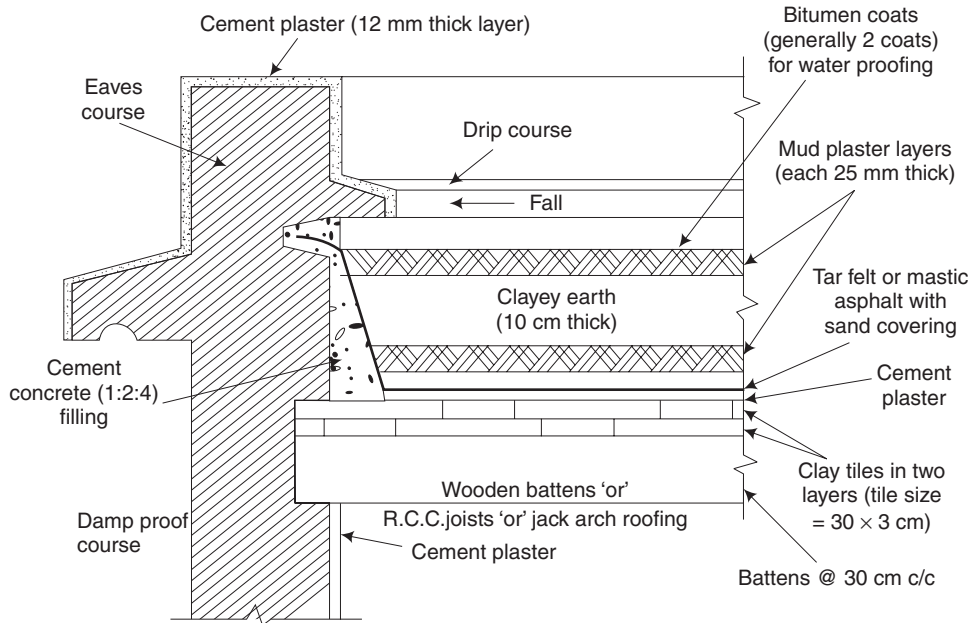
Sectional elevation

**Fig. 5.37** *Weather proofing using C.C. tiles*



Sectional elevation

**Fig. 5.38** *Weather proofing using plastic transparent films*



**Fig. 5.39** Weatherproofing using clay tiles, tar felt, etc.

**2. Floor covering (or flooring)** This is the covering over the subfloor and is meant to provide a hard, clean, smooth, impervious, durable and attractive surface to the floor.

A floor may be defined as a building component that divides a building in different levels, for the purpose of creating accommodations within a restricted space, at levels one above the other.

The bottom-most floor of a building is called the ground floor and the other floors above it are termed the upper floors or first floor, second floor etc. If the floor is below the natural ground level, it is called a basement floor.

### 5.8.1 Selection of Floorings

Each type of flooring has its own merits and there is not even a single type which can be suitably provided under all circumstances. However, the selection of flooring can be made considering the following factors:

1. Initial cost
2. Appearance
3. Cleanliness
4. Durability
5. Damp resistance
6. Sound insulation
7. Thermal insulation
8. Smoothness
9. Hardness
10. Comfortability
11. Fire resistance
12. Maintenance

### 5.8.2 Materials Usually Employed for Flooring

[Nov, Dec 2011]

The flooring is laid over the base floor. The different materials used for flooring are:

1. Mud and moorum
2. Stones
3. Bricks
4. Wood or timber
5. Concrete
6. Mosaic
7. Terrazo
8. Asphalt
9. Plastic or PVC
10. Tiles
11. Rubber
12. Linoleum
13. Granolithic
14. Cork
15. Magnesite
16. Glass
17. Marble

### 5.8.3 Requirements or Qualities of a Good Floor

1. It should give a hard and smooth surface.
2. It should have adequate strength and stability.
3. It should be damp-resistant.
4. It should have good thermal insulation capacity.
5. It should be durable and easy to maintain.
6. It should be fire-resistant.
7. It should have an aesthetic look.

### 5.8.4 Components of a Floor

Structurally, a floor may consist of two main components:

1. Sub-floor or base course
2. Floor covering

The sub-floor or base floor provides proper support to floor covering. The floor covering provides a smooth, clean, impervious and durable surface.

### 5.8.5 Types of Flooring

[Nov, Dec 2011; May, June 2012]

The various types of commonly used ground floor finishes are as follows:

1. Mud and moorum flooring
2. Brick flooring
3. Stone flooring
4. Concrete flooring
5. Granolithic flooring
6. Terrazzo flooring
7. Mosaic flooring

8. Marble flooring
9. Wood or timber flooring
10. Asphalt flooring
11. Industrial flooring
12. Granite flooring
13. Linoleum flooring

### **1. Mud and Moorum Flooring**

#### **Mud Flooring**

**Method of construction** The floor bed should be well prepared and a 250 mm thick layer of selected moist earth is evenly spread out and is rammed well so as to get a consolidated thickness of 150 mm. No water is used during the process of ramming. In order to prevent formation of cracks after drying, chopped straw in small quantity is mixed with the moist earth before ramming. Upon this bed, a thin coat of cement, cowdung plaster (1 cement: 4 cowdung) is applied evenly and wiped clean by hand.

#### **Moorum Flooring**

**Method of construction** In this type of floor, a hard bed is prepared by laying a 25-cm thick layer of hand packed rubble boulders and then wetted and rammed hard. Upon this hard bed, a 15-cm thick layer of moorum (disintegrated rock) with coarse pieces at the bottom and finer at the top is laid. Over this layer of moorum another 25-mm thick layer of powdered moorum is spread. Water should then be sprinkled on the entire surface and rammed well. Finally, over the dry hard surface a thin coat of cement plaster (1 cement: 4 cowdung) is applied evenly and wiped cleanly by hand.

**Suitability** Mud floors are generally used for unimportant buildings particularly in villages.

**Advantages** They are cheap, hard, fairly impervious and easy in construction and maintenance.

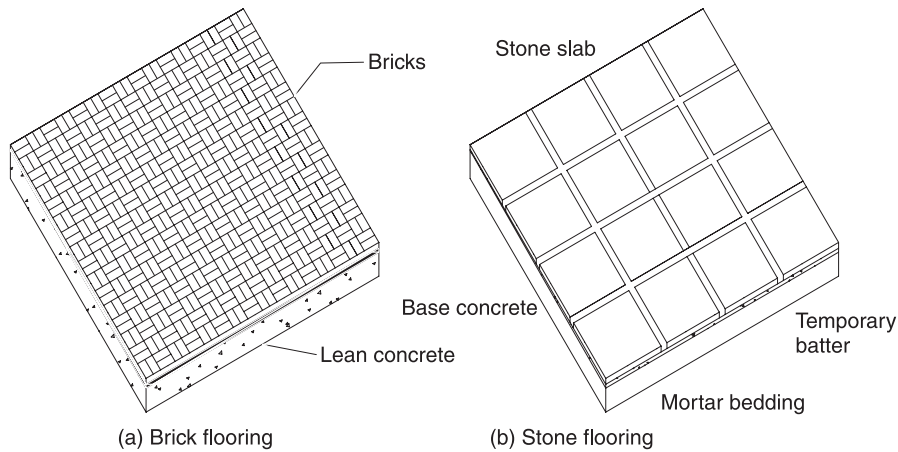
### **2. Brick Flooring**

**Method of construction** In this flooring the subgrade is compacted properly to the desired level. 10-15 cm thick layer of lean cement concrete ( 1: 8: 16) or lime concrete is laid over the prepared subgrade. This forms the base course, over which bricks are laid in desired pattern on 12mm thick mortar bed in such a way that all the joints are filled with mortar.

**Suitability** Brick floors are suitable for warehouses, stores and godowns or in places where bricks are available economically.

**Advantages** This floor is cheap, non-slippery, durable, sufficiently hard and easily repairable.





**Fig. 5.40** *Brick and stone flooring*

### 3. Stone Flooring

**Method of construction** The subgrade is prepared by laying a 100 mm to 150 mm thick layer of cement or lime concrete over a bed of well consolidated earth. The stone slabs may be square or rectangular, usually 300 mm × 300 mm, 450 mm × 450 mm, 600 mm × 600 mm or 450 mm × 600 mm size. The thickness of stone varies from 20 mm to 40 mm. The selected stone should be hard, durable, good quality and of uniform thickness and the surface. The stones should be finely chisel dressed on surface and should have their edges true and parallel from side top side. When the stone slabs are properly set, mortar in the joints is raked out to a depth of 20 mm and flush pointed with cement mortar 1:3.

**Suitability** This type of flooring is suitable for godowns, sheds, stores, bus shelter, schools, hospitals, etc.

**Advantages** Where stones are available in plenty, this floor is economical. It is hard, durable, easy to construct and has good resistance to wear and tear.

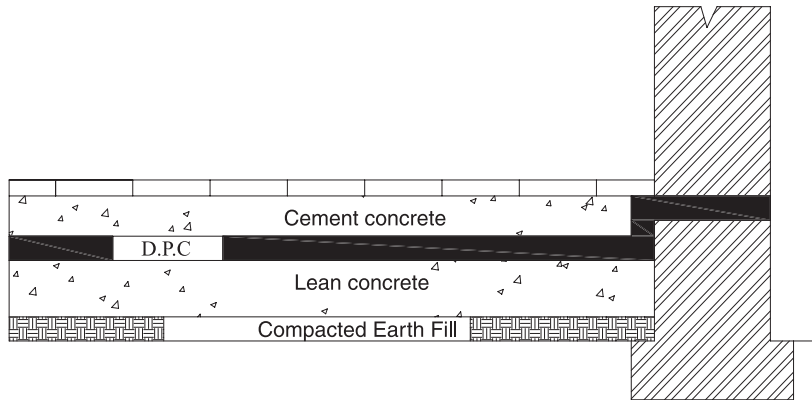
### 4. Cement Concrete Flooring

**Method of Construction** This flooring is commonly used for residential, commercial and even industrial buildings.

The floor consists of two components:

- (i) **Base concrete** The base course is laid over well-compacted soil, compacted properly and leveled to a rough surface. The base course consists of 7.5 cm to 10 cm thick cement concrete (1:3:6 to 1:5:10). The top surface of the concrete base is roughly finished to develop good bond between the base and topping.
- (ii) **Wearing surface** After the base concrete has hardened, its surface is brushed with stiff broom and cleaned thoroughly. The entire surface is divided into square or rectangular panels not exceeding 2.5 m in length. Cement concrete 1:2:4 of thickness 25 mm to 40 mm is then laid in alternate panels. The top surface is beaten and made

in a uniform line and level, and finally it is smoothed by trowelling. The surface is kept under curing for 10 days.



**Fig. 5.41** *Cement concrete flooring*

**Suitability** It is suitable for residential, commercial, industrial and public buildings of all types.

**Advantages** It is cheap and durable, easy to maintain and it is fire resistant.

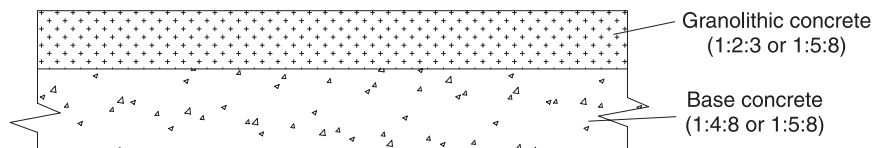
### 5. Granolithic flooring

[Nov, Dec 2011]

**Method of Construction** In this flooring the sub-base preparation and concrete base laying is done in a similar manner, as explained for cement concrete flooring. A finishing layer is given above is made of very rich concrete mix with hard stone chips, called granolithic finish. To improve wearing qualities, sand may be replaced by crushed granite powder. The surface may be finished smooth with a steel trowel. The floor area may be divided into panels of size 600 mm × 600 mm or 600 mm × 450 mm using threads, if desired.

**Suitability** This type of flooring is mostly suitable for industrial floors.

**Advantages** It is durable, cheap, resistant to abrasion and does not wear easily.



**Fig. 5.42** *Granolithic flooring*

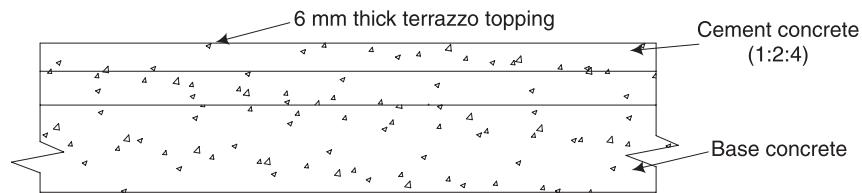
### 6. Terrazzo flooring

**Method of construction** In this flooring the sub-base preparation and concrete base laying is done in a similar manner, as explained for cement concrete flooring. The top layer may have about 40 mm thickness, consisting of (i) 34 mm thick cement concrete layer(1:2:4) laid

over the base concrete, and (ii) about 6mm thick terrazzo topping. Terrazzo is a specially prepared concrete surface consisting of white cement with marble chips of different colours in 1:2 proportion, laid in a thin layer over a concrete base course. Even though this flooring is expensive, it is decorative and has good wearing properties.

**Suitability** This type of flooring is suitable for hospitals, public buildings, living room and bathrooms of residential buildings, etc.

**Advantages** It provides an attractive, clean and durable surface.



**Fig. 5.43** *Terrazzo flooring*

**Disadvantages** It is more expensive.

### 7. Mosaic flooring

**Method of Construction** Mosaic flooring is made of small pieces of broken tiles of glazed china, cement, or of marble, arranged in different patterns. These pieces are cut to desired shapes and sizes. This floor is normally laid over a hard bed of cement concrete. The top surface of the concrete base is cleaned and wetted. On a small portion of the floor, a layer of rich cement, mortar 1:3 is evenly spread in a thickness of nearly 1cm and mosaic tiles are laid with hand and set properly in desired pattern. Dry cement either ordinary or coloured is sprinkled and pressed in the joints. The process is continued for the whole floor. The joints of the tiles are then rubbed with a corborundum stone. After the tiles are set, the surface is completely polished with a mosaic-polishing machine.

**Suitability** This type of flooring is suitable for use in operation theatres, bathrooms, public buildings, etc.

### 8. Marble flooring

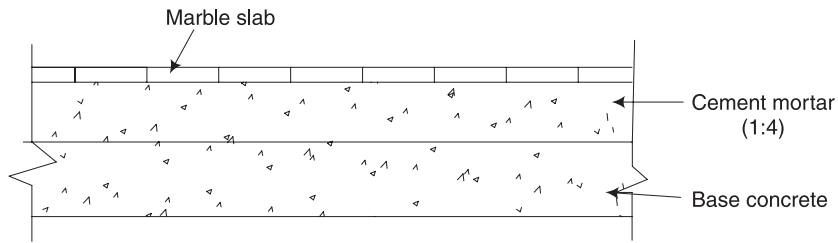
[Nov, Dec 2011]

**Method of Construction** This flooring is laid over the prepared subgrade which is cleaned, wetted and mopped properly. A layer of cement mortar of 1:4 is spread in an average thickness of about 20 mm. Marble slabs are laid in this bedding mortar, pressed and leveled. The marble slabs may be rectangular or square in shape and their thickness varies from 20 to 40 mm. The joints between two slabs must be very thin. The cement that oozes out of the joints is cleaned. The paved area is cured for a minimum of seven days.

**Suitability** It is suitable for places of worship and for public buildings which require rich appearance, kitchens, bathrooms, operation theatres and hospitals. etc.,

**Advantages** It is attractive and easily maintained.

**Disadvantages** It requires high initial cost.



**Fig. 5.44** *Marble flooring*

### 9. Wood or Timber Flooring

**Method of construction** Timber flooring is used for dancing halls, auditoriums, etc. There are two types of timber floors:

- (i) Suspended type
- (ii) Solid type

**(i) Suspended-type timber flooring** Where the problem of dampness is acute, the timber flooring is provided above the ground level. In such a case, sleeper walls are constructed at centre to centre distance of 1.2 to 1.8 m. Wall plates are provided along the sleeper walls. The bridging joists of timber are nailed to the wall plates at their ends. They are placed at a centre to centre distance of about 30 cm. Finally, the floor boards are provided on the bridging joists to finish up the floor.

**(ii) Solid-type timber flooring** Where the problem of dampness is not acute, timber floors may be supported on the ground all along. In this type of flooring base concrete is first laid in 15 cm to 20 cm thickness. Over it a layer of mastic asphalt is applied. Wooden block flooring is then laid over it. In order to fix the wooden floor on concrete slabs, longitudinal nailing strips, with beveled sections, are embedded in concrete at suitable intervals.

**Suitability** It is suitable for dancing halls, auditoriums, carpentry halls, in hilly areas, where timber is available cheaply and in areas where temperature is very low.

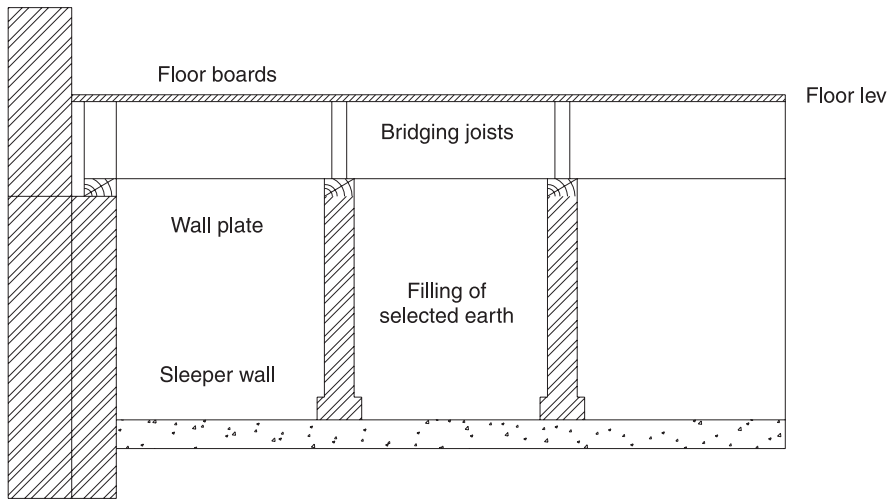
**Advantages** It provides a non-slippery platform and is easy to repair.

**Disadvantages** This flooring is not commonly used for residential buildings due to its cost. Dampness prevention should be carried out before its construction.

### 10. Asphalt flooring

**Method of Construction** Mastic is melted and clean sand is mixed with it and laid in one or two layers on the base of the concrete with a trowel. A uniform level surface can be obtained by quick trowel line before the mastic loses its plasticity and before it gets hardened.

**Suitability** It is suitable for use under a wide range of service conditions from light domestic buildings to heavy duty commercial and industrial buildings, storage houses, foot paths etc.



**Fig. 5.45** *Suspended type timber floor*

**Advantages** Mastic asphalt flooring is dustless, jointless and impervious. The flooring is easily cleaned and resistant to acids.

Asphalt floorings are of the following types.

- (i) Asphalt mastic flooring
- (ii) Asphalt tiles flooring
- (iii) Asphaltic terrazzo flooring
- (iv) Acidproof mastic flooring

**1. Asphalt mastic flooring** Asphalt mastic is a mixture of sand (or grit) and asphalt in the ratio of 2:1. It is mixed hot and then is laid in continuous sheets. It can also be applied cold, by mixing with mineral oil and asbestos. The thickness of the asphalt mastic may be 2.5 cm for ordinary construction. It is laid on cement concrete base and is spread by means of trowel to get a levelled surface. On the top of the surface, a thin layer of sand is spread, which is then rubbed with a trowel. The joints of mastic asphalt laid on successive days are properly lapped.

**2. Asphalt tiles flooring** These are prepared from asphalt, asbestos fibres, inert materials and mineral pigments, by pressing the mix in different sizes ( $20\text{cm}^2$ – $45\text{cm}^2$ ), with thickness varying from 3–6 cm. Those tiles are either directly cemented to concrete base or are fixed on wooden floors by using an intervening layer of mastic asphalt or asphalt saturated felt. Asphaltic tiles are cheap, resilient, soundproof, non-absorbent and moisture proof.

**3. Asphaltic terrazzo flooring** This is prepared like mastic asphalt, except that marble chips are used in the place of sand/grit. Asphalt may be either in black or other suitable colours and is laid in hot condition.

**4. Acidproof mastic flooring** Acidproof blocks of asphalt are available, which are manufactured from moulding acidproof asphalt and inert crushed rock aggregate under

high pressure. Asphalt blocks are first laid on concrete base and then acidproof asphalt is uniformly spread over the surface of the blocks. Fine sand is spread over the liquid asphalt before it hardens.

### 11. Industrial Flooring

In most of the industries, cement concrete flooring is commonly adopted since it is moderately cheap, easy to construct and quite durable. The floor consists of the following two components:

- (a) *Base concrete*
- (b) *Wearing surface*

The two components of the floor can be constructed either monolithically (i.e. laying the wearing surface immediately after the base concrete is laid) or non-monolithically. The method of laying cement concrete flooring on ground floor of an industry can be broadly divided into the following three steps:

- (a) Preparation of sub-base
- (b) Laying of the base concrete
- (c) Laying the wearing surface

**1. Preparation of sub-base** The earth filling in plinth is consolidated thoroughly so as to ensure that no loose pockets are left in the whole area. Then a 10–15 cm thick layer of clean coarse sand is spread over the whole area. The sand layer is consolidated and dressed to the required level and slope.

**2. Laying of base concrete** The base course may be 7.5–10 cm thick, either in lean cement concrete (1:3:6 to 1:5:10) or lime concrete containing 40 per cent mortar of 1:2 lime-sand (or 1 lime : 1 surkhi : 1 sand) and 60 per cent coarse aggregate of 40 mm nominal size. The base course is laid over well-compacted soil, compacted properly and levelled to rough surface. It should be properly cured.

**3. Laying the wearing surface** The wearing surface is laid in square or rectangular panels, by using either glass or plain asbestos strips or by using wooden battens set on mortar bed. The panels may be 1 × 1 m, 2 × 2 m, 1 × 2 m in size. The wearing surface consists of 1:2:4 cement concrete, laid to the thickness of 4 cm. Before laying the concrete in the panel, a coat of neat cement slurry is applied to ensure proper bond of topping with the base course.

Advantages

- (a) It possesses good wearing properties.
- (b) It is easy to construct and maintain.
- (c) It is non-absorbent, smooth and pleasing in appearance.
- (d) It is durable and hence it is commonly used in factories and industries.
- (e) It is economical.

Disadvantages

- (a) It cannot be satisfactorily repaired by patch work.
- (b) Defects in carelessly made floor cannot be rectified and as such, it requires proper attention while laying.

### **12. Granite Flooring**

Granite flooring is a superior type of flooring commonly used in residential buildings, shopping complex, hospitals, offices, etc. where extra cleanliness is an essential requirement. Granite stone is available in the form of 8 mm and 12 mm thick tiles and 20 mm thick slab. These tiles and slabs are available in any shape and size. Before laying the tiles, neat cement slurry is spread over the bedding mortar and the tiles are laid flat over it. Then they are pressed gently into the bedding mortar with the help of wooden mallet, till a levelled surface is obtained. Also, a thin paste of cement is applied on the bottom of the tiles before laying. After a day, the joints between adjacent tiles are cleaned of loose mortar, etc. to a depth of 5 mm. This is done by using wire brush and then the joints are grouted with cement slurry of the same colour shade as that of the tiles. The flooring is then cured for seven days.

### **13. Linoleum Flooring**

Linoleum is produced from linseed oil, pigments, gum and wood or cork flour. Linoleum is laid on wooden or concrete floors to improve their durability and appearance. It is available in rolls having various colors and designs. Linoleum tiles are also available. It is attractive, economical and easy to wash. But it does not offer resistance against dampness and fire. Linoleum flooring is used in railway coaches, ships etc.

## **5.9 DAMP-PROOFING**

Damp-proofing is the method adopted to prevent the entry of dampness into a building, so as to keep them dry, habitable and safe. The provision of damp-proofing courses prevents the entry of moisture from walls, floors and basement of a building.

**1. Causes of dampness** There are various causes which are responsible for the entry of dampness in a structure. They are listed below.

**(i) Entry of moisture from the ground** Building materials used in the foundation may absorb moisture from the pervious soil by capillary action. This will lead to the entry of dampness to the floor and walls.

**(ii) Entry of rain water** The unprotected exposed surfaces and leaking roofs become sources of entry of rain water into a structure thereby leading to dampness.

**(iii) Exposed tops of walls** Dampness may enter through the exposed tops of parapet walls and compound walls. This may lead to serious consequences.

**(iv) Deposition of atmospheric moisture on walls, floors and ceilings** When warm humid air is cooled, condensation of water vapour takes place. This is the main source which

causes dampness in walls, floors and ceilings. This is evident mainly in badly designed kitchens.

**(v) Location** Dampness will enter into the structure which is located on a site that cannot be easily drained.

**(vi) Orientation of walls** The walls obtaining less sunshine and heavy showers of rain are liable to become damp.

**(vii) Workmanship** The dampness is also caused due to bad workmanship in construction such as defective rainwater pipe connections, defective joints in the roofs, improper connections of walls, etc.

**2. Effects of dampness** Following are the effects of dampness in a structure:

1. A damp building creates unhealthy conditions for those who occupy it.
2. Corrosion of the metals used in building construction is evident.
3. Formation of unsightly patches on the wall surfaces and ceilings.
4. Formation of dry-rot leading to the decay of timber in a damp atmosphere.
5. Deterioration of electrical fittings.
6. Floor covering materials are seriously damaged.
7. Acceleration of the growth of termites.
8. Softening and crumbling of the plaster.

**3. Requirement of an ideal material for damp-proofing**

1. The damp-proof course should remain effective during the life of the building. Hence, the material should be durable.
2. It should remain steady and should not allow any movement in itself.
3. It should be impervious.
4. The material should safely resist the load coming on it.
5. It should be strong enough to undergo some structural movement without fracture.

**4. Materials used for damp-proofing**

**(i) Hot bitumen** It is flexible and should be applied with a minimum thickness of 3 mm.

**(ii) Mastic asphalt** It is a semi-rigid material and it forms an excellent impervious layer. It is very durable but can withstand only slight distortion.

**(iii) Bituminous felts** It is also flexible and it is available in rolls of normal width. This can accommodate slight movements. It is liable to squeeze out under pressure.

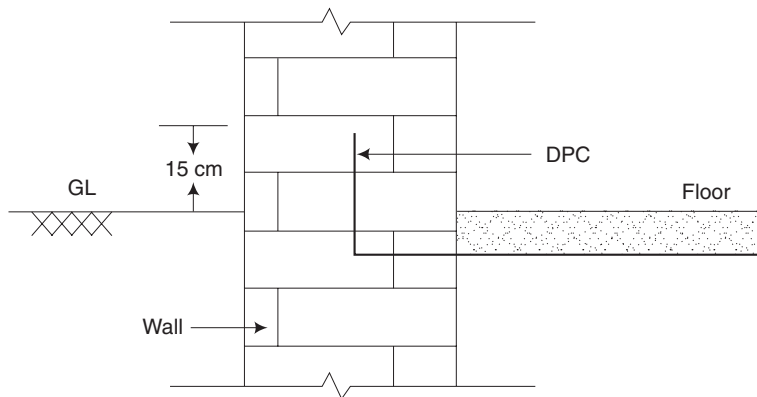
**(iv) Metal sheets of lead, copper and aluminium** Metal sheets can also be used as damp-proofing material. These metal sheets are flexible and do not squeeze out under pressure. The surface of lead coming in contact with lime and cement will be corroded and hence



it should be protected with bitumen. Aluminium sheets should also be protected with bitumen but copper does not require any protective coating.

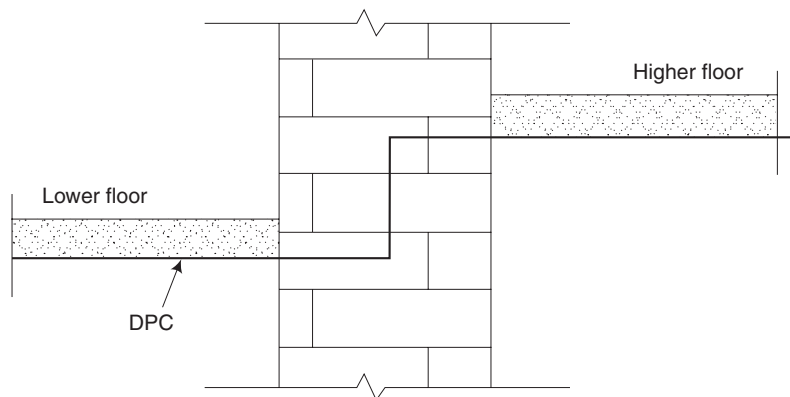
### 5. Methods of damp-proofing

1. If the level of the ground floor is in level with the ground surface or just above it, the damp-proofing course is provided as shown in Fig. 5.46.



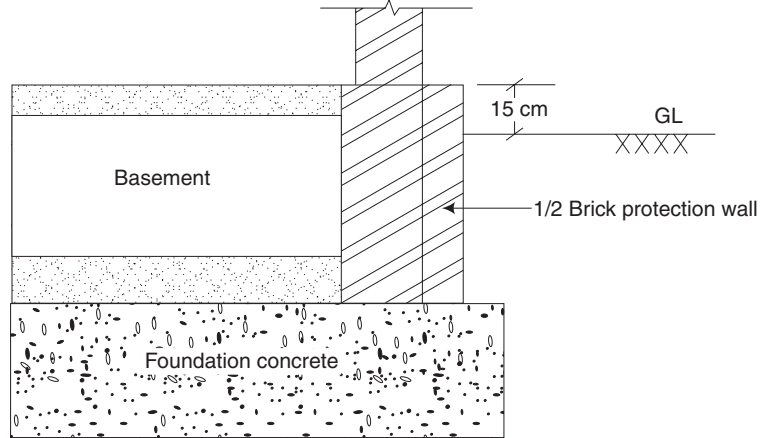
**Fig. 5.46** Damp-proofing for ground floor in level with ground surface

2. If two ground floors are at different levels, DPC is provided as shown in Fig. 5.47.

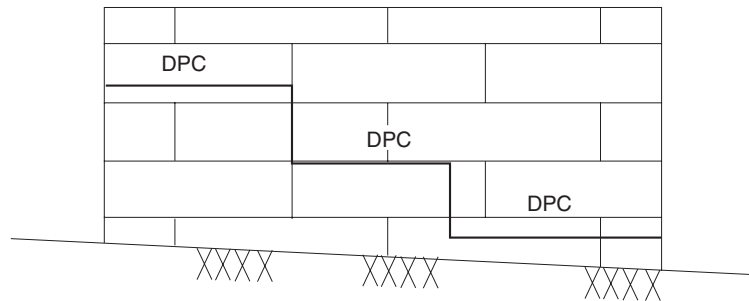


**Fig. 5.47** Damp-proofing for floors at different levels

3. In case of basements, the damp proofing course should be properly provided. The usual practice is to provide asphalt tanking as shown in Fig. 5.48.
4. In case of sloping ground, the damp proofing course should be steeped such that it remains at a minimum vertical distance of 15 cm above ground as shown in Fig. 5.49.



**Fig. 5.48** *Damp-proofing for basements*



**Fig. 5.49** *Damp-proofing for sloping ground*

## 5.10 PLASTERING

[Nov, Dec 2010]

Plastering is the process of covering rough walls and uneven surfaces in the construction of houses and other structures with a plastic material called plaster or mortar.

### 5.10.1 Objectives of Plastering

[May, June 2011]

1. To provide an even, smooth, regular, clean and durable finished surface and hence to improve the appearance.
2. To protect the surfaces from the effects of atmospheric agencies.
3. To conceal the defective workmanship.
4. To cover up the use of inferior quality and porous materials and the joints formed in masonry work.
5. To provide a satisfactory base for whitewashing, colour washing, painting or distempering.
6. In the case of internal plastering, the object is to protect the surfaces against dust and vermin nuisance.

### 5.10.2 Types of Plasters

[Nov, Dec 2010]

**1. Lime plaster** Lime plaster is an intimate mixture of equal proportions of lime and sand, ground in a mortar mill to form a paste of required consistency. Sand to be used in the mortar should not pass through a 100-mesh sieve for more than five per cent or a 50 mesh sieve for more than 20 per cent. Water and sand used should be clean and free from all deleterious materials.

Fat lime or poor lime is used in lime plaster. To improve the strength of lime mortar, small quantity of cement is added. This mortar is mainly used for external work.

**2. Cement plaster** Cement plaster is an intimate mixture of Portland cement and sand with required amount of water to make a plastic mass. The proportion of cement and sand depends upon the nature of work. The ingredients are first mixed in a dry state and water is added to make a paste. This plaster should be used within 30 minutes since cement starts setting after 30 minutes.

**3. Mud plaster** Mud plaster is prepared with equal volumes of clay or brick earth and of chopped straw, hay, loose soil or cowdung and hemp. The ingredients are mixed and left for seven days with large quantity of water. Then, it is again mixed till it reaches the required consistency before using. Mud plaster made of sand and clay can also be used.

**4. Waterproof plaster** This plaster consists of one part of cement, two parts of sand and pulverised alum at the rate of 12 kg/m<sup>3</sup> of sand. In order to make this to be waterproof, soap water containing about 75 gm soap/litre of water is added.

### 5.10.3 Requirements of a Good Plaster

1. It should provide a smooth, non-absorbent and washable surface.
2. It should not shrink while drying which results in cracking of the surface.
3. It should adhere firmly to the surface and resist the effects of atmospheric agencies.
4. It should offer good insulation against sound and high resistance against fire.
5. It should provide to a decorative appearance the surface and should be durable.

### 5.10.4 Methods of Plastering

Plaster may be applied in one, two or three coats. In the cheapest construction, one coat of plaster is used. In ordinary works, two coats are adopted and in superior jobs, three coats are applied.

**1. Plastering in two coats** The procedure for carrying out the plastering in cement in two coats is as follows:

1. The mortar joints are raked out to a depth of 20 mm and the surface is cleaned and well watered.
2. If the surface to be plastered is very rough, a preliminary coat is applied.

3. The first coat of plaster is now applied with a thickness of 9 mm to 10 mm for brick masonry. To maintain uniform thickness, screeds are formed on the wall surface by fixing dots. Fixing a dot is just placing small quantity of plaster making a square of 150 mm × 150 mm. Another dot is placed vertically below this and a vertical strip of plaster connecting these two dots is provided. This is a screed. Screeds are placed at a distance of 2 m and plaster is applied between them.
4. The second coat is applied after about 6 hours and the thickness of second coat is about 3 mm to 12 mm. It is finished as per the requirements.
5. The completed work is allowed to set for 24 hours and it is well watered for at least one week.

**2. Plastering in three coats** The procedure for plastering in three coats is the same as the above except that the number of coats is three. It is done as detailed in Table 5.2.

**Table 5.2** Plastering in three coats

Coat	Name of coat	Thickness	Remarks
First coat	Rendering coat	9 mm to 10 mm	Left for a period of 3 to 4 days to harden. Surface is kept rough.
Second coat	Floating coat	6 mm to 9 mm	The purpose is to prepare an even surface.
Third coat	Setting or finishing coat	3 mm	This is similar to the second coat of two-coat plaster.

Plaster in three coats with lime mortar is done as explained in Table 5.3.

**Table 5.3** Plaster in three coats with lime mortar

Coat	Name of coat	Thickness	Remarks
First coat	Rendering coat	12 mm	Left for a period of 2 days to set and not to dry.
Second coat	Floating coat	6 mm to 9 mm	Applied with trowels and rubbed with straight edge. Water is sprinkled and the surface is rubbed with floats to make it an even surface.
Third coat	Setting or finishing	3 mm	Applied after 5 days. Neeru or agol coat is used to prepare a smooth surface. After giving a set of 24 hours, the work is well watered for a fortnight.

### 5.10.5 Defects in Plastering

[May, June 2011]

1. Small patches swell out beyond the plane and this is particularly seen inside the building. This is known as blistering of plastered surface.
2. Cracks are formed on the surface which may be visible or invisible. The development of fine hair cracks is known as crazing.
3. Soluble salts are present in plaster materials as well as in building materials. When newly constructed wall dries out, soluble salts appear as a white crystalline

substance. This is referred to as efflorescence and this effects the adhesion of paint with wall surface.

4. The formation of a very small loose mass on the plastered surface is known as flaking and it is due to the failure of bond between coats of plaster.
5. The plaster from some portion of the surface comes off and a patch is formed. This is known as peeling and is also due to failure of bond in coats of plaster.
6. Sometimes, the plaster may contain particles which expand on setting. A conical hole is formed on the surface which is known as blow or pop.
7. Rust stains are seen on the plastered surface, especially when plaster is applied on metal lath.
8. The excessive dampness at certain points on the surface makes that portion soft. The reasons are, due to the presence of thinners in the finishing coat, presence of deliquescent salts, excessive suction of the undercoat, etc.
9. Uneven surface is due to poor workmanship.

#### **5.10.6 Remedies for Minimising the Defects in Plastering Work**

1. Workmanship should be the best in brick work and plastering work.
2. Bond of brickwork should be proper.
3. Efflorescence is removed by rubbing brushes on the surface. A solution of 1 part of HCl acid or  $H_2SO_4$  acid and 5 parts of clean water is prepared and applied on the affected area. The surface is then cleaned with water. The surface is kept under observation for few days. If efflorescence appears again, it is removed and painting can be done only when it ceases.
4. Bricks of superior class should be used.
5. The surface to be plastered should be well watered so that it may not absorb water from the plaster.
6. Excessive trowelling should be avoided.
7. Damp-proof courses should be provided at convenient places in the building.
8. Fresh plastered surfaces should be protected from superfluous quantity of water and excessive heat.

#### **5.11 VALUATION**

Value means worth of an asset. Valuation implies the act of estimating the price for an asset, based on its present condition.

In general, all properties are classified broadly into two categories: immovable property and movable property.

Immovable property includes land, buildings, mines, trees, quarries, etc. Movable property includes things which can be moved from place to place, e.g., coal, oil, building materials such as steel, cement, jelly and sand. Movable properties are otherwise called chattels.

The value of a property is based on principles of economics. There are many factors influencing the value of a property and they will vary from place to place and type of property. So valuation needs a thorough understanding regarding the property, as it is a money matter.

### 5.11.1 Objectives of Valuation

The purpose of valuation is to arrive at a fair and reasonable price for any existing property.

The following are main objectives of valuation of a property:

- 1. Buying and selling of the properties** Whenever one wants to buy or sell a property, one must be aware of the value prevailing in the market at that time.
- 2. Taxation** Tax schedule is prepared based on valuation only. Government taxes such as estate duty, wealth-tax, capital gain tax and gift tax are calculated based on valuation only.
- 3. Security of loans** When loans are to be granted against a property, the valuation of the property has to be carried out.
- 4. Rent determination** In order to determine the probable amount of rent from a property such as a house, valuation is essential.
- 5. Compulsory acquisition** Sometimes a property may be acquired by law and, in that case, the owner of the property has to be paid a suitable compensation. The above is possible through valuation.
- 6. Speculation** Sometimes a person may purchase a property, with a view to develop it in future. To gauge the potential of a property, valuation is necessary.
- 7. Private development** Valuation becomes essential for a property to be purchased by a person with a view to improve it for personal use.
- 8. Betterment charges** When the property comes under some town-planning scheme of the area, its value will increase and consequently, the owner has to pay additional tax known as betterment charges. So, it becomes necessary for the owner to know the value of his property before and after the town-planning scheme execution.
- 9. Court fees, registration charges** When a case has to be filed with respect to a real estate, valuation becomes necessary, to affix the stamp of suitable amount. Similarly for transferring a property, the registration charges are fixed based on the value of property only.
- 10. Insurance** For the purpose of insuring a property, valuation is necessary.
- 11. Reinstatement** The process of reinstating a property needs its current value.

### 5.11.2 Valuation of Building

The value of a building depends on the type of the building, its structure, the quality of materials used in the construction, and so on. The value of the building also depends on the place of location, the height of the building, the height of plinth, the thickness of wall, the type of floor, roof, doors and windows, etc. The value also depends on the demand which varies from time to time.

While valuing a building, the age of the building should be obtained from the past records.

The following methods are used for the valuation of a building:

**1. Rental method of valuation** In this method, net income by way of rent is determined by deducting the outgoings from the gross rent.

$$\text{Net income} = \text{Gross rent} - \text{Outgoings}$$

Then a suitable interest is assumed and year's purchase is calculated. Now, the value of the building is obtained as the product of net income and year's purchase.

**2. Direct comparison with capitalised value** This method may be adopted if the rental value of a building is not available but the sale price of a similar property is available. The value of the concerned property is fixed in comparison with the value of similar property in the locality.

**3. Valuation based on profit** This method is suitable for public buildings such as hotels, cinema theatres, auditoriums and music halls for which the value depends on the profit. For the above cases, the value is obtained by multiplying the net profit with the year's purchase.

$$\text{Net profit} = \text{Gross income} - \text{Outgoings}$$

**4. Valuation based on cost** In this approach, the actual cost of the constructed property is found after allowing for necessary depreciation and the resulting figure is taken as the value of the property.

**5. Development method of valuation** In this method, the anticipated value of a property is obtained by multiplying the net income with the year's purchase. The property mentioned above includes those which are not at present in good condition, needing additions, alterations, improvements etc. In such a case, the value can be obtained upon anticipating the future net income from it.

**6. Depreciation method of valuation** It is worth to discuss the above method in detail. Depreciation refers to gradual loss of the value of a property due to wear and tear, excess usage, improper handling, age, etc. Depreciation technique involves collecting or providing an amount equal to the loss due to depreciation every year, separately from the profit. So that, when the property is sold at the end (scrap value) it can be replaced by a new one with the scrap value and the total depreciation amount.

As far as a building is concerned, depreciation method of valuation based on plinth area is a well known one.

### 7. Area-based valuations

**(a) Plinth-area estimate** This estimate is prepared on the basis of plinth area of the building. The plinth area rate is obtained from the cost of similar building having similar specifications, height and construction in the locality.

Plinth area is the built-up covered area of a building measured at floor level of any storey. It is calculated by taking the external dimensions of the building at the floor level excluding plinth offsets. Courtyard, open areas, balconies and cantilever projections are not included in the plinth area.

The following shall be included in the plinth area:

- (i) All floors, area of walls at the floor level excluding plinth offsets, if any
- (ii) Internal shafts for sanitary installations provided if these do not exceed 2 sq.m. in area, air condition ducts, lifts, etc.
- (iii) The area of *barsati* and the area of *mumty* at terrace level
- (iv) Area of porches other than cantilevers

The following shall not be included in the plinth area:

- (i) Area of loft
- (ii) Internal sanitary shafts provided if these area more than 2 sq.m. in area
- (iii) Unenclosed balconies
- (iv) Towers, turrets, domes, etc., projecting above the terrace level, not forming a storey at the terrace level
- (v) Architectural bands, cornices, etc.
- (vi) Sunshades, vertical sun breakers or box louvers projecting out.

Approximate cost of the building may be found using the formula:

Approximate cost of the building

$$= \text{Total plinth area} \times \text{Plinth area rate of the building in the locality}$$

Approximate area for different types of buildings are given in Table 5.4.

**Table 5.4** Approximate area of different types of building

Type of building	Floor area per head	Area occupied by wall
Residential	2.5 to 3.0 sq.m.	15 to 20% of plinth area
School	1.0 to 2.0 sq.m.	15 to 20% of plinth area
Hotel	7.0 to 10.0 sq.m.	15 to 20% of plinth area
Hospital	8.0 to 10.0 sq.m.	15 to 20% of plinth area
Factory	2.5 to 3.0 sq.m.	10% of plinth area
Office	2.5 to 3.0 sq.m.	10% of plinth area



(b) *Carpet-area estimate* Carpet area of the building is the useful area or the livable or lettable area. The carpet area of the building shall be the floor area excluding the following:

- (i) Sanitary accommodation
- (ii) Verandah
- (iii) Corridors and passages
- (iv) Kitchen and pantries
- (v) Stores in domestic building
- (vi) Entrance hall
- (vii) Staircases and munties
- (viii) Shafts for lifts
- (ix) Barsaties
- (x) Garages
- (xi) Canteens
- (xii) Air-conditioning ducts and rooms

The floor area can be determined by deducting the area occupied by the walls from the plinth area.

The carpet area of an office building may be 60–70 per cent of the plinth area and that of a residential building may be 50–60 per cent of the plinth area.

### *Illustrative Examples*

**Example 5.1** Determine the value of a building if the plinth area is 160 sq.m. using the straight line method of depreciation.

Rate of plinth area = Rs 1000/sq.m.

Rate of depreciation = 1.25 % per year

Period of consideration 10 years.

**Solution** Present value of the building =  $1000 \times 160 = \text{Rs } 1,60,000$

Depreciation at the rate of 1.25% for 10 years

$$= 1,60,000 \times \left( \frac{1.25}{100} \right) \times 10 = \text{Rs } 20,000$$

Value of the building after allowing the depreciation

$$= \text{Rs } 1,60,000 - 20,000 = \text{Rs } 1,40,000$$

**Example 5.2** Calculate the value of a building if the carpet area of the building is 98 sq. m. Rate of plinth area is Rs 1550/sq.m. and rate of depreciation is 1.2% per annum. The present age of the building is 13 years. Take the carpet area as 70% of the plinth area.

**Solution** Carpet area of the building = 98 sq.m.

$$\text{Carpet area} = \left( \frac{70}{100} \right) \times \text{Plinth area}$$

$$98 = \left(\frac{70}{100}\right) \times \text{Plinth area}$$

$$\text{Plinth area} = 98 \times \left(\frac{100}{70}\right) = 140 \text{ sq.m.}$$

$$\text{Valuation before depreciation} = \text{Rs } 1550 \times 140 = 2,17,000$$

$$\text{Depreciation for 13 years} = \text{Rs } 2,17,000 \times \left(\frac{1.2}{100}\right) \times 13 = 34.852$$

$$\text{Value of the building after depreciation} = \text{Rs } 2,17,000 - 33,852 = \text{Rs. } 1,83,148$$

**Example 5.3** Calculate the approximate cost of the residential building having a carpet area of 2000 sq.m. Plinth area rate is Rs. 1000/sq.m.

**Solution** Carpet area = 50 to 60% of plinth area

Assuming carpet area as 50% of plinth area

$$\text{Plinth area} = \left(\frac{100}{50}\right) \times \text{Carpet area}$$

$$\text{Plinth area} = 2 \times 2000 = 4000 \text{ sq.m}$$

$$\text{Approximate cost of the building} = \text{Plinth area rate} \times \text{Plinth area}$$

$$= \text{Rs. } 1000 \times 4000 = \text{Rs. } 40,00,000$$

**Example 5.4** Calculate the plinth area, carpet area and floor area for the plan of the building given in Fig. 5.22.

**Solution** Plinth area =  $6.6 \times 6.9 = 45.54 \text{ sq.m.}$

Floor area = Plinth area – area occupied by walls

$$\text{Area occupied by walls} = (2 \times 4.2 \times 0.3) + (2 \times 6 \times 0.3) + (2 \times 2.7 \times 0.2)$$

$$+ (1 \times 2.7 \times 0.3) + (1 \times 2.5 \times 0.2) \text{ sq.m.}$$

$$= 2.52 + 3.60 + 1.08 + 0.81 + 0.50 \text{ sq.m.}$$

$$= 8.51 \text{ sq.m}$$

$$\text{Floor area} = 45.54 - 8.51 \text{ sq.m} = 37.03 \text{ sq.m}$$

Carpet area = Floor area – non-usable area

$$\text{Floor area of verandah} = 3.4 \times 2.5 = 8.5 \text{ sq.m}$$

$$\text{Floor area of Bath and W.C.} = 2.5 \times 2.5 = 6.25 \text{ sq.m}$$

$$\text{Carpet area} = 37.03 - (8.50 + 6.25) = 22.28 \text{ sq.m}$$

**Example 5.5** The actual expenditure incurred in the construction of a single storey residential building of plinth area  $72 \text{ m}^2$  is found to be Rs 1,02,600 in which 60% is towards the cost of the materials and the remaining is towards the cost of the labour. It is now proposed to construct a similar building of the same height and specifications with the

plinth area of  $94 \text{ m}^2$  at a place where the cost of materials is 10% more and the cost of the labour is 20% less. Estimate approximately the cost of the proposed building.

**Solution** Total cost of the existing building = Rs 1,02,600

$$\text{Plinth area of existing building} = 72 \text{ m}^2$$

$$\text{Plinth area rate} = 1,02,600/72 = \text{Rs } 1,425 \text{ per m}^2$$

$$\text{Cost of materials} = 0.6 \times 1425 = \text{Rs. } 855 \text{ per m}^2$$

$$\text{Cost of labour} = 0.4 \times 1425 = \text{Rs. } 570 \text{ per m}^2$$

$$\text{Increase in cost of materials} = 10\%$$

$$\text{Decrease in cost of labour} = 20\%$$

$$\begin{aligned} \text{Plinth area rate for the proposed building} &= (1.1 \times 855) + (0.8 \times 570) \\ &= \text{Rs } 1396.50 \text{ per m}^2 \end{aligned}$$

$$\text{Plinth area of the proposed building} = 94 \text{ m}^2$$

$$\text{Approximate cost} = 94 \times 1396.50 = \text{Rs } 1,31,271$$

The approximate cost of the proposed building is Rs. 1,31,271.

**Example 5.6** The particulars regarding a two-storeyed building are given below:

$$\text{Plinth area of ground (first) floor} = 82 \text{ m}^2$$

$$\text{Plinth area of second floor} = 68 \text{ m}^2$$

$$\text{Expenditure for the construction of ground floor} = \text{Rs } 1,10,700$$

$$\text{Expenditure for the construction of second floor} = \text{Rs } 80,240$$

Estimate the probable cost of a similar building proposed to be constructed in the same locality with plinth areas of  $96 \text{ m}^2$  in ground floor and  $80 \text{ m}^2$  in second floor.

**Solution** Plinth area rate for ground floor =  $1,10,700/82 = \text{Rs } 1,350 \text{ per m}^2$

$$\text{Plinth area rate for second floor} = 80,240/68 = \text{Rs } 1,180 \text{ per m}^2$$

$$\text{Probable cost for the proposed building} = (96 \times 1350) + (80 \times 1180) = \text{Rs } 2,24,000$$

The probable cost of the proposed building is Rs 2.24 lakhs.

### Short-Answer Questions

1. What is meant by bonding of bricks?
2. Classify stone masonry based on its construction.
3. Give a list of types of bonds in brick work.
4. What is meant by valuation?
5. What are the factors affecting the value of a building?
6. What are the types of plasters?
7. What are the advantages of granolithic flooring?

8. What is carpet area?
9. How are properties classified for the purpose of valuation?
10. What are the factors to be considered while selecting a suitable roofing material?
11. What is a truss?
12. What is meant by built-up column?
13. What are the components in the superstructure of a building?
14. Explain the following terms with neat sketches:
  - (a) Arrises
  - (b) Stretcher
  - (c) Header
  - (d) Bed joint
  - (e) Perpend
  - (f) Lap
  - (g) Queen closer
  - (h) King closer
  - (i) Bevelled closer
  - (j) Mitred closer
  - (k) Bat
  - (l) Bull nose
  - (m) Cow nose
  - (n) Squint quoin
15. Explain with neat sketch the stretcher bond for one-brick thick wall.
16. Explain with neat sketch the header bond for one-brick thick wall.
17. What are the causes of cracks in a brick masonry wall?
18. Write down the remedial measures to prevent cracks in brick masonry wall.
19. Explain the following terms in stone masonry.
  - (a) Natural bed
  - (b) Sill
  - (c) Corbel
  - (d) Cornice
  - (e) Coping
  - (f) Weathering
  - (g) Throating
  - (h) Plinth
  - (i) String course
  - (j) Lacing course
  - (k) Spalls
  - (l) Quoins
  - (m) Through stone
  - (n) Jambs
  - (o) Heads
  - (p) Buttress
  - (q) Plaster
20. Distinguish between spandrels and stringers.
21. How does a one-and-a-half brick English bond wall look?
22. What is the necessity for providing weatherproof course?
23. Write a short note on any one technique of weather proofing in RCC slab roofs.
24. Where is stone flooring provided and why?
25. What are the components of industrial flooring?
26. How can the method of laying cement concrete flooring be broadly divided?
27. What are the advantages of cement concrete flooring?

28. What are the disadvantages of industrial flooring?
29. What are the types of asphalt flooring?
30. What is damp-proofing?
31. Mention the causes of dampness.
32. What are the effects of dampness?
33. List out the requirements of an ideal material for damp-proofing.
34. Which materials are used for damp-proofing?

### *Exercises*

1. What is a queen closer and where is it used?
2. Explain the different types of brick masonry normally adopted.
3. Draw a neat sketch of a one-brick thick English bond and explain its features.
4. What are the characteristics of a Flemish bond? Give a neat sketch.
5. What are the factors which decide the thickness of the wall?
6. What are the points to be observed while supervising the brick work?
7. What are the causes for cracks in a masonry wall?
8. Explain the various kinds of rubble masonry with necessary sketches.
9. Explain ashlar masonry with a neat sketch.
10. What are the points to be observed while supervising the stone work?
11. Compare brick masonry with stone masonry.
12. Write short notes on the following:
  - (a) Beams
  - (b) Columns
  - (c) Lintels
13. Explain the purpose of lintel and their types.
14. What are roofs? Explain briefly a reinforced cement concrete roof.
15. For an industrial building, what type of roof can be adopted?
16. Explain the various roof coverings normally adopted.
17. What are the advantages and disadvantages of flat roofs?
18. What is a floor? What are the materials normally used for the construction of a floor?
19. Explain the construction of the following type of floors:
  - (a) Cement concrete flooring
  - (b) Mosaic flooring
  - (c) Terrazo flooring
  - (d) Tiled flooring

20. What are the objectives of plastering?
21. Explain the method for the preparation of different types of mortar for plastering.
22. What are the requirements of a good plaster?
23. Explain the two-coat plastering method.
24. What is the difference between the three-coat and two-coat methods of plastering?
25. What are the defects in plastering? How can these be rectified?
26. For what purposes is valuation necessary?
27. Explain the various methods adopted to find the value of a building.
28. How can the value of an open area be determined?
29. What is the depreciation method of valuation?
30. How will you calculate the plinth area of a building?
31. What is a plinth-area estimate?
32. Explain the method of valuation by carpet area.
33. Calculate the value of a building if the carpet area of the building is 80 sq.m, rate of plinth area is Rs 1650 per sq.m, and rate of depreciation is 1.5 per cent per annum. The present age of the building is 10 years. Assume that the carpet area is 80 per cent of the plinth area.
34. Find the value of a building if the total area is 250 sq.m and the plinth area is about 85 per cent of the total area. Use the straight line method of depreciation.  
Rate of plinth area = Rs 1500 per sq.m  
Rate of depreciation = 1.5 per cent per year  
Period of consideration = 20 years
35. Write short notes on one-and-a-half brick thick English bond.
36. Explain the purpose of weatherproof course.
37. Explain the construction of the following types of flooring.
  - (a) Stone flooring
  - (b) Industrial flooring
  - (c) Asphalt flooring
  - (d) Granite flooring
38. What are the causes and effects of dampness in a structure?
39. What is damp-proofing? What are the materials used for it?
40. Describe the various methods of damp-proofing.

# Chapter 6

## BRIDGES

### 6.1 INTRODUCTION

[Nov, Dec 2012]

A bridge is a structure providing passage over an obstacle such as a valley, road, railway, canal, river, without closing the way beneath. The required passage may be for road, railway, canal, pipeline, cycle track or pedestrians.

The branch of civil engineering which deals with the design, planning construction and maintenance of bridges is known as bridge engineering.

### 6.2 NECESSITY OF BRIDGES

Bridges are vital for the development of a country since these enable transporting materials from one area to the other which may be separated by streams and rivers, thereby maintaining uniform flow of essential goods for development. In times of war, materials are swiftly transported for the defence needs of the country by railroad bridges. Bridges link the whole country with road and railway communication maintaining a uniform flow of people, goods and other essential commodities. The necessity of bridges may therefore be summarised as follows:

1. Bridges enable the free flow of traffic during monsoons and other periods of inclement weather.
2. Bridges provide additional communication facilities.
3. The development of the backward districts which may be rich agriculturally critically depends on the existence of bridges.
4. Bridges provide more socio-economic benefits to the people.
5. Bridges also enable movement of troops and military vehicles during hostilities.

### 6.3 SITE INVESTIGATION

[May, June 2013]

Before a bridge is constructed, a suitable site is selected based on certain factors which have bearing on the economy and stability of the bridge. Reconnaissance is therefore made and the following data are recorded to determine the feasibility of bridge construction:

Considered while selecting the site for a bridge are the following:

1. The bridge should cross the river at right angles to the direction of flow of stream or river water so as to minimise the length of the bridge.
2. The banks on either sides of the river should have firm soil and be straight and well-defined. This will increase the stability of the bridge and reduce the possibility of the erosion of the banks. Also, the soil need not be stabilised or given any other treatment which will increase the cost.
3. The selected site should be at a place where the river is narrow and the flow is streamlined without serious whirls and cross currents. Small width reduces the length of the bridge which means less cost of construction and maintenance. If the flow of water is uniform and parallel, it is a reliable guard against scour.
4. Precautions should be taken to see that the selected site should be far away from where the river is likely to change the course. If the bridge has been constructed and the river has changed its course, the bridge will be rendered useless.
5. Hard inerodable strata or rock should be available close to the river-bed level.
6. There should not be any sharp curves in road approaches.

#### 6.4 PRELIMINARY DATA TO BE COLLECTED

[May, June 2013]

The engineer in-charge of the investigation for a bridge should collect the following information before the construction of a bridge is undertaken:

**1. Volume and Nature of Traffic** Not only the present volume and nature of traffic but also the future volume which is expected in the next ten years should be collected. The size and the type of the bridge required depend on this data.

**2. Velocity of the Stream and High Flood Level (HFL) Attained** The discharge of water passing through the bridge depends on the velocity of water. It will help in designing the proper size of the waterway and pier thickness. The velocity of the stream during high flood and also during normal flow can be determined with the help of the current meter or velocity rods. The High Flood Level (HFL) will enable a bridge engineer to determine the height of free board which is the height of the road way above the HFL. It is necessary to prevent the washing away of the bridge during heavy floods.

**3. Catchment Area** It is an area of that portion of watershed from which water flows and feeds the river. This is necessary to calculate the discharge of the stream.

**4. Strength and Nature of Soil and Extent and Type of Vegetation** The depth of foundation for the piers and abutments depends on the strength of soil. This is determined by carrying out borings at several places and testing the soil samples. Extent and type of vegetation along with climatic conditions are also noted.

**5. Frequency of Flood Occurrence and Rainfall Details** The determination of flood frequency is an important factor as most of the bridges are designed for a flood frequency of 50 years. Amount of rainfall and the HFL are also noted for future design.



**6. Scour Depth Determination** Eroding of the bed of river due to heavy discharge and the velocity of water known as scour has a great bearing on the design of the depth of foundation of piers and abutments. Hence, the extent to which the bed of the river may scour below the HFL is determined according to which the design is made.

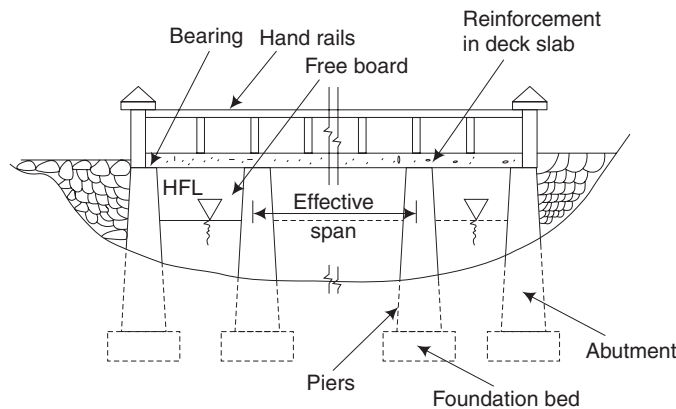
In addition to the above, the following data should also be collected.

1. Name of the river, road and location of the probable bridge sites
2. Location of the nearest Great Trigonometric Survey (GTS) bench mark with its Reduced Level (RL)
3. Navigational requirements, if any, for the river
4. Availability, quality and location of the nearest quarries for stones, for masonry and for concrete aggregates
5. Nearest place of availability of cement, steel and timber
6. Means of transport for materials
7. Availability of electric power
8. Availability of skilled and unskilled labour
9. Facilities required for housing labour during construction
10. Liability of the site to earthquake disturbances

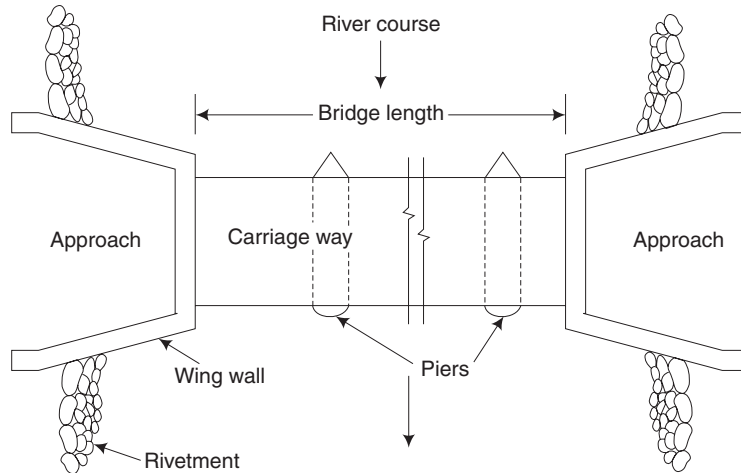
## 6.5 COMPONENTS OF A BRIDGE

[Nov, Dec 2010, 2012]

Figure 6.1 (a) shows the elevation while Fig. 6.1(b) presents the plan of a bridge. Broadly, a bridge can be divided into two major parts: superstructure and substructure. The *superstructure* of a bridge is analogous to a single-storey building roof and *substructure* to that of the walls, columns and foundations supporting it.



**Fig. 6.1(a)** Elevation of a bridge



**Fig. 6.1(b)** Plan

**Superstructure** Superstructure consists of structural members carrying a communication route. Thus, handrails, guardstones and flooring supported by any structural system, such as beams, girders, arches and cables, above the level of bearings form the superstructure.

[Nov, Dec 2012]

**Substructure** Substructure is a supporting system for the superstructure. It consists of piers, abutments, wingwalls and foundations for the piers and abutments.

The other main parts of a bridge structure are the approaches, bearings and river training works, such as the aprons, and the rivetment for slopes at abutments, etc. Some of the important components of a bridge are explained in this section. [Nov, Dec 2012]

**Piers** These are provided in between the two extreme supports of the bridge (abutments) and in the bed of the river to reduce the span and share the total load coming over the bridge. Piers are provided with foundation which is taken below the bed of the river where hard soil is available.

**Abutments** The end supports of a bridge superstructure are called abutments. It may be of brick masonry, stone masonry, RCC or precast concrete block. It serves both as a pier and as a retaining wall. The height of abutment is equal to that of the piers. The functions of an abutment are the following:

1. To transmit the load from the bridge superstructure to the foundations
2. To give final formation level to the bridge superstructure
3. To retain earth work of embankment of the approaches

**Wing Walls** The walls constructed at both end of the abutments to retain the earthfilling of bridge approaches are called wing walls. Normally, the wing walls have steadily

decreasing cross-section. The design of wing walls is independent. Generally, the water face of these walls is kept vertical.

**Foundations** The lowest artificially built parts of piers, abutments, etc., which are in direct contact with the subsoil supporting the structure are called foundations.

The factors which affect the selection of foundation include the type of soil, the nature of soil, the type of the bridge, the velocity of water and the superimposed load on the bridge.

Well foundation is the most commonly adopted bridge foundation in India. The foundation may consist of a single large diameter well or a group of smaller wells of circular or other shapes.

**Approaches** These are the lengths of communication route at both ends of the bridge. Approaches may be in embankment or in cutting depending upon the design of the bridge. It is recommended (as per Indian Road Congress) that the approaches must be straight for a minimum length of 16 m on either side of the bridge. Its function is to carry the communication route up to the floor level of the bridge.

**Hand Rails and Guard Stones** Hand rails are provided on both sides of a bridge to prevent any vehicle from falling into the stream. Footpaths are also provided for pedestrians to walk along without interfering with the heavy vehicular traffic.

In order to prevent a vehicle from striking the parapet wall or the hand rails, guard stones painted white are provided along the edge of the footpaths at the ends of the road surface. Guard stones are also provided along both sides of the approach roads in filling to prevent the vehicles from toppling over the sides of the embankments.

**Bearings for the Girders** The longitudinal girders have to rest over the piers which bear the thrust of the load coming over them. In order that the girder ends should rest on proper seats, the same are provided with bearing blocks made of cement concrete, so that the load may be uniformly distributed over the structure on which they rest. Due to the expansion and contraction of the longitudinal girders during severe heat and cold, rollers are provided on the abutment ends to allow the movements without causing the girder to buckle.

## 6.6 TECHNICAL TERMS

1. **Span** It is the centre to centre distance between two supports.
2. **Culvert** It is a small bridge having maximum span of 6 m.
3. **Vent way** It is a culvert having a length less than 1 m.
4. **High Flood Level (HFL)** It is the level of the highest flood ever recorded in a river or stream.
5. **Ordinary Flood Level (OFL)** It is the flood level which generally occurs every year.
6. **Low Water Level (LWL)** It is the minimum water level in the dry weather.
7. **Waterway** The area of opening which allows maximum flood discharge to pass under the bridge without increasing the velocity to a dangerous limit is called waterway.

8. **Afflux** Due to construction of the bridge, there is a contraction in waterway. This results in rise of water level above its normal level while passing under the bridge. This rise is known as afflux.
9. **Free board** The difference between the HFL and the level of the crown of the road at its lowest point is called free board.
10. **Head room** It is the vertical distance between the highest point of a vehicle or vessel and the lowest point of any protruding member of a bridge.
11. **Length of the bridge** The length of a bridge structure will be taken as the overall length measured along the centre line of the bridge from the end to the bridge deck.
12. **Viaduct** It is a continuous structure which carries a road or railway like a bridge, over a dry valley composed of series of spans over trestled bents instead of solid piers.
13. **Causeway** It is a *pucca* submersible bridge which allows floods to pass over it. It is provided on less important routes in order to reduce the construction cost of cross-drainage structures. It may have vents for low water flow.

## 6.7 CLASSIFICATION OF BRIDGES

**According to the Expected Utility of Service** The bridges are classified as temporary and permanent bridges.

**1. Temporary bridges** The bridges which are constructed and maintained at low cost and have short span of life are called temporary low cost bridges, e.g., timber bridges. Temporary bridges are constructed in the following cases:

- (i) During construction of dams
- (ii) During construction of permanent bridges
- (iii) For crossing river during *melas*
- (iv) During repair work of permanent bridges
- (v) During survey work for projects
- (vi) For transporting timber from one bank to the other in forests.

These bridges are dismantled when the object of their construction is fulfilled.

**2. Permanent bridges** These are bridges which are constructed and maintained at high cost and have a long span of life.

These bridges are built to last for centuries, e.g., steel bridges and RCC bridges.

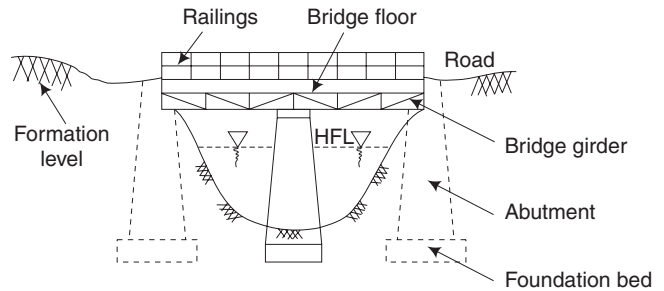
**According to the Position of the Floor of the Bridge** Relative to formation level and highest flood discharge, the bridges are classified as deck bridges, through bridges and semi-through bridges.

**1. Deck bridges** When the platform of a bridge, carrying the communication route is supported at the top of the superstructure, i.e., when the superstructure of a bridge is

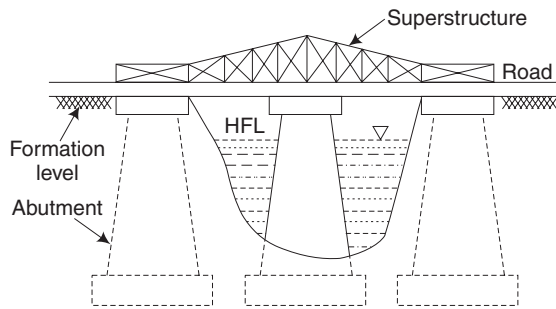
accommodated between the high flood level and the formation level then the bridge is known as the deck bridge which is shown in Fig. 6.2.

**2. Through bridge** When the platform of a bridge, carrying the communication route is suspended at the bottom of the superstructure, i.e., when the superstructure of a bridge projects completely above the formation level then the bridge is known as through-type bridge (shown in Fig. 6.3).

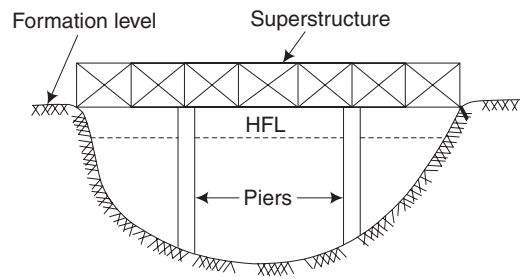
**3. Semi-through Bridge** When the superstructure of a bridge projects partly above and partly below the formation level, it is known as semi-through bridge or pony bridge and is thus an intermediate type between deck and through types. Figure 6.4 shows a semi-through bridge.



**Fig. 6.2** Deck bridge



**Fig. 6.3** Through bridge



**Fig. 6.4** Semi-through bridge

**According to the Inclination of Bridge** With respect to the axis of water (i.e., direction of flow of water), the bridges are classified as straight bridges and skew bridges.

**1. Straight bridge** The bridge which is at right angles to the axis of flow of water is called straight bridge. This type of crossing is also known as *square crossing*.

**2. Skew bridge** The bridge which is constructed at some angle other than  $90^\circ$  to the flow of water is known as a skew bridge. It is better to always avoid a skew bridge because it has the following disadvantages:

- (a) The foundations are likely to be scoured.
- (b) Construction of skew arches is difficult.
- (c) Maintenance is costly and difficult.
- (d) The piers have to resist additional water pressure, as whirls are produced. Hence, special care must be taken to ensure that the pier is parallel to the current.

**According to the Position of High Flood Level**

**1. Submersible or low-level bridge** It is the bridge which allows the highest flood to pass over its superstructure. These bridges are generally constructed on unimportant routes and when sufficient funds are not available. In this case, storm water runs only for a short period of the year. The stream remains dry for the rest of the year or normal flow runs under the bridge.

**2. Non-submersible or high-level bridge** It is a bridge which does not allow the high flood water to pass over the floor carrying the communication route.

This type of bridge is of permanent nature. It is constructed on important highways and to carry an unobstructed traffic throughout the year. Moreover, sufficient funds should be available for its construction.

**According to the Type of Superstructure**

- |                  |                       |
|------------------|-----------------------|
| 1. Arch bridges  | 2. Girder bridges     |
| 3. Truss bridges | 4. Suspension bridges |

**According to the Method of Providing Clearance in Navigation Channels**

- |                    |                        |
|--------------------|------------------------|
| 1. Movable bridges | 2. Transporter bridges |
|--------------------|------------------------|

**According to the Span**

1. Culvert (span less than 6 m)
2. Minor bridges (span between 8–30 m)
3. Major bridges (span above 30 m)
4. Long-span bridges (span above 120 m)

**According to the Loadings** Road bridges and culverts have been classified by Indian Road Congress (IRC) into Class AA, Class A and Class B bridges according to the loadings they are designed to carry.

**According to the Level of Crossing of Highways and Railways**

**1. Overbridge** The bridge constructed to allow a highway to pass over another communication route (railway) is called an overbridge.

**2. Underbridge** The bridge constructed to allow a road to pass under another communication route is known as an underbridge.

**According to their Function** According to their function or purpose, bridges are classified as

- |                    |                   |
|--------------------|-------------------|
| 1. Foot bridge     | 2. Highway bridge |
| 3. Railway bridge  | 4. Viaduct bridge |
| 5. Aqueduct bridge |                   |

**According to Materials**

[May, June 2009]

- |                                |                   |
|--------------------------------|-------------------|
| 1. Timber bridge               | 2. Masonry bridge |
| 3. Steel bridge                | 4. RCC bridge     |
| 5. Prestressed concrete bridge |                   |

### According to the Interspan Relationship

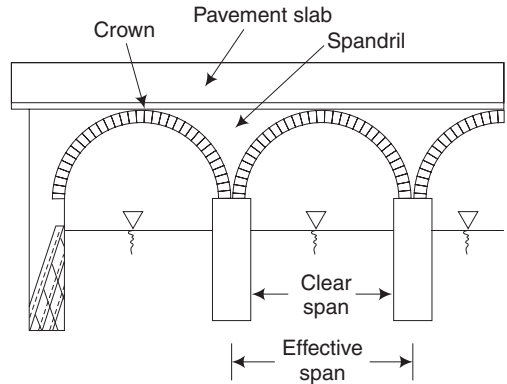
1. Simple bridge
2. Continuous bridge
3. Cantilever bridge

#### Arch Bridge

Arch bridges are often used because of their pleasing appearance. These are more graceful and suited for deep gorges with rocky abutments. Arch bridges can be economically adopted up to a span of 250 m. In this type of bridge, the roadway is constructed on an arch which rests on piers and abutments as shown in Fig. 6.5. An example of an arch bridge is the rainbow bridge across the Niagara river over a span of 290 m.

The advantages of an arch bridge are:

1. There will be no bending anywhere in the arch
2. Vibrations due to impact forces are minimum
3. Pleasing appearance

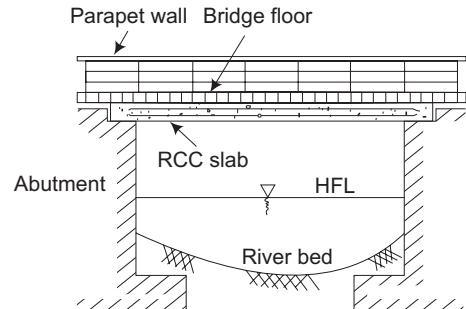


**Fig. 6.5** Arch bridge

#### Slab Bridge

[May, June 2014]

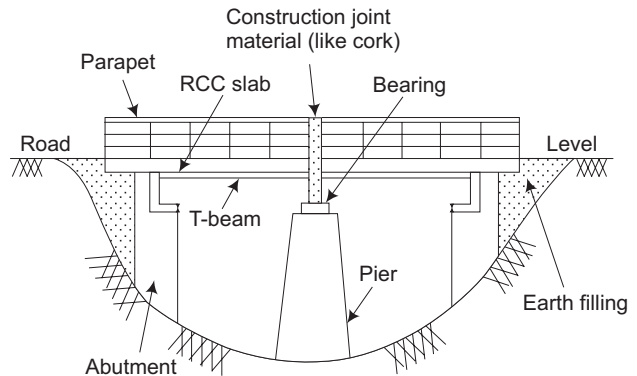
This is the simplest type of RCC bridge and easiest to construct. Slab bridges are generally found to be economical for a span of up to 9 m. The thickness of the slabs is quite considerable but uniform, thereby requiring simple shuttering. Though the amount of concrete and steel required are more, the construction is much simpler and placement of material is easy. Figure 6.6 shows a slab bridge.



**Fig. 6.6** RCC slab bridge

#### T-Beam and Slab Bridge [May, June 2010]

This consists of T-beams supported over piers and abutments as shown in Fig. 6.7. The deck slab is supported over the T-beams. This type of bridge is suitable for spans between 9 – 20 m. A T-beam bridge is cheaper and requires less quantity of materials. For example, the longest RCC T-beam bridge in India is the Advai Bridge in Goa with a pier spacing of 35 m.

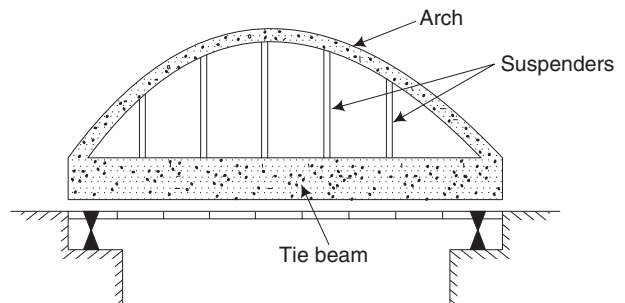


**Fig. 6.7** RCC T-beam and slab bridge



### Bow-String Girder Bridge

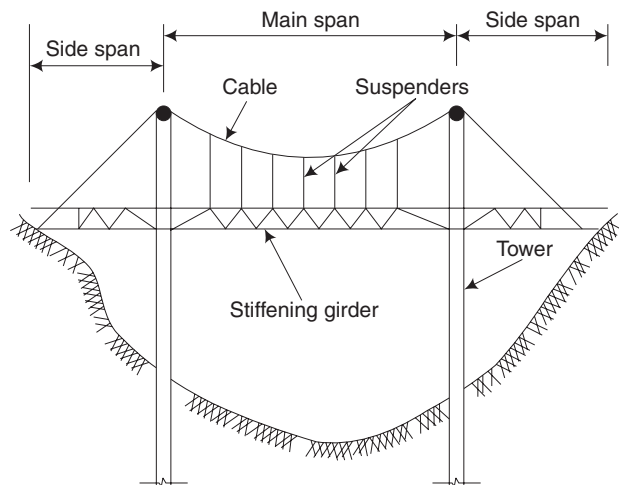
Bow-string girder bridges are economical when sufficient head room is needed under a bridge. The main components here are an arch resembling the bow and a tie beam resembling the string of the bow. As the major portion of the load will be borne by the beam, the thrust on the abutments from the arch will be limited. Hence, the abutments need not be too heavy. The roadway is actually suspended from the arch rib by means of vertical suspenders as presented in Fig. 6.8. These bridges can be adopted for spans of 30–45 m.



**Fig. 6.8** *RCC bow string girder bridge*

### Suspension Bridge

Superstructure of a suspension bridge consists of two sets of cables over the towers, carrying the bridge floor by means of suspenders as shown in Fig. 6.9. This bridge is best suited for light traffic for large spans exceeding 600 m. These bridges are flexible and hence the vertical oscillations will be more than the other bridges. The entire load will be borne by the cables which are anchored to the ground.



**Fig. 6.9** *Stiffened suspension bridge*

### Prestressed Concrete Bridge

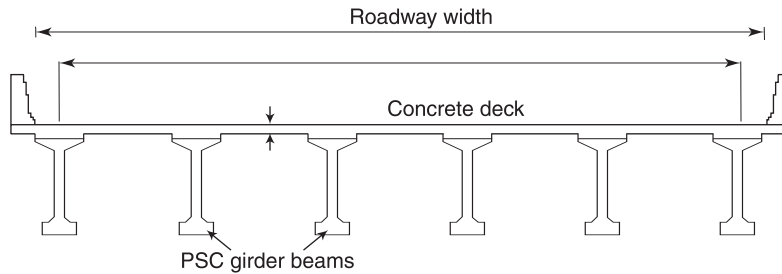
Prestressed concrete (PSC) which is made up of high strength concrete and high tensile steel has distinct advantages in bridge construction.

Prestressed concrete is ideally suited for composite bridge construction in which precast prestressed girders support the cast *in situ* slab deck.

Post tensioned prestressed concrete elements are used for long span bridges.

Prestressed concrete is ideally suited for medium and long span bridges. Solid slabs are used for a span ranging from 10 m to 20 m, while T beam slab deck are suitable for spans ranging from 20 m to 40 m. Box Girders are used for large span ranging from 30 m to 70 m. Prestressed concrete is ideally suited for long span continuous bridges exceeding more than 50 m. Prestressed concrete has been widely used throughout the world for simply supported, continuous, cantilever, suspension type bridges in the span range of 20 m to 500 m.





**Fig. 6.10** PSC bridge

### Steel Bridges

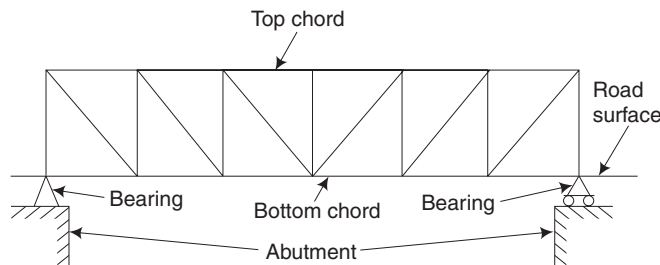
Steel bridges are commonly used for supporting highways, water, oil or gas pipes, a railway track, etc. They can be classified as follows:

1. Steel truss bridges
2. Steel rigid frame bridges
3. Plate girder bridges
4. Steel arch bridges
5. Steel bow string girder bridges
6. Movable bridges

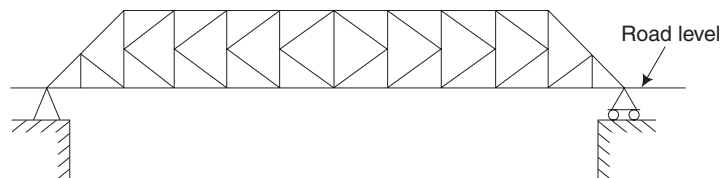
### Steel Truss Bridges

Steel truss bridges are provided for long railway bridges, as they are less affected by wind pressure. It is easy to erect steel truss bridge since its component members are relatively light in weight. The primary forces in its members are axial forces. Steel truss bridges which are commonly used are the following and are shown in Fig. 6.11, respectively.

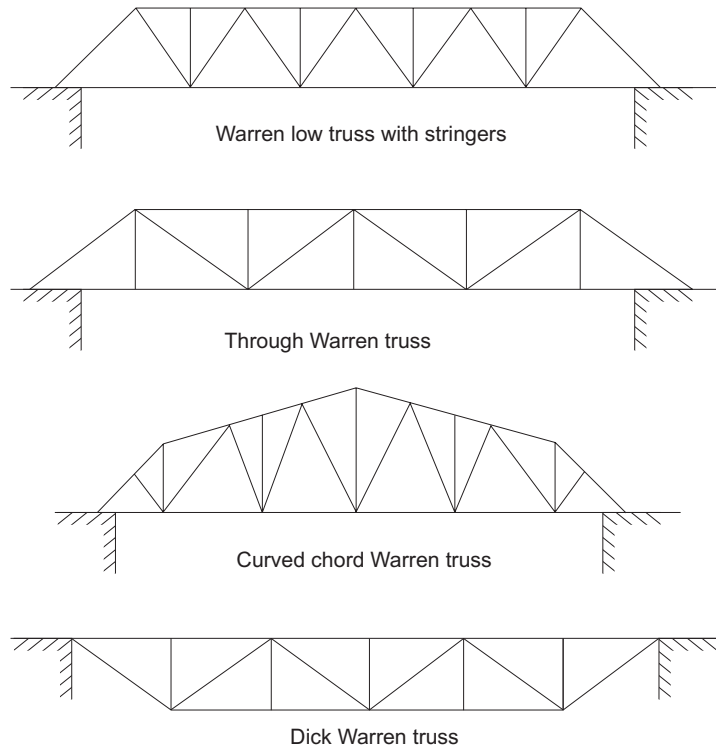
1. N-truss bridge
2. K-truss bridge
3. Warren truss bridge
4. Pratt truss bridge
5. Curved chord Pratt bridge



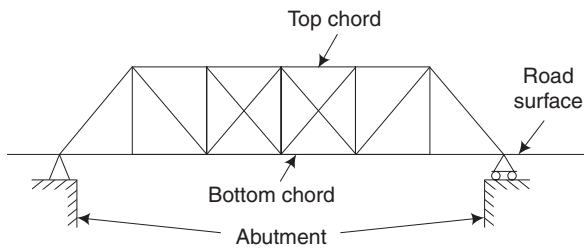
**Fig. 6.11(a)** N-truss bridge



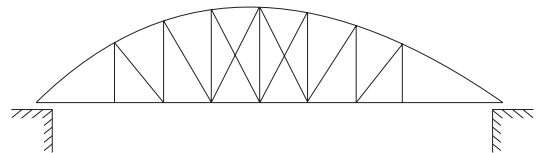
**Fig. 6.11(b)** K-truss bridge



**Fig. 6.11(c)** *Warren bridge*



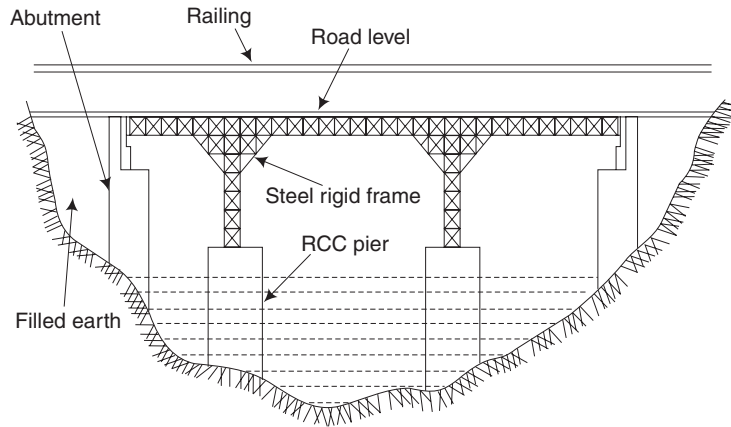
**Fig. 6.11(d)** *Pratt truss bridge*



**Fig. 6.11(e)** *Curved chord Pratt bridge*

### *Steel Rigid-Frame Bridge*

These type of bridges carry the roadway at the top of the portal frames. No bearing and fixtures are required in such bridges. These bridges have more clearance below them and heavy abutments are not required. The structure of such a bridge is shown in Fig. 6.12.



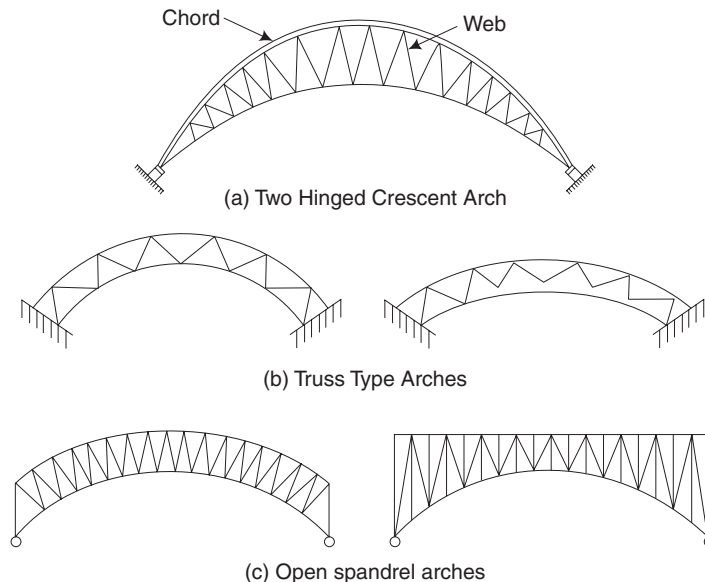
**Fig. 6.12** *Steel rigid-frame bridge*

### *Plate-Girder Bridges*

A plate-girder bridge is used to carry heavier loads over longer spans. Hence, they are mainly used for railway bridges. These are used for spans of up to 20 m. In order to increase the lateral stability, box girders which consist of four plates connected by angles are used.

### *Steel Arch Bridges*

Steel arch bridges are constructed where it is not possible to construct an intermediate pier. It can be used for a very long span, i.e., of up to 150 m. Steel arches may either be of the spandrel-braced or trussed-arch type, as shown in Fig. 6.13.



**Fig. 6.13** *Different types of steel arches*

### Steel Bow-String Girder Bridges

In steel bow-string girder bridges, in order to bear horizontal thrust, a steel tie is provided which joins the two ends of an arch. In these bridges, suspenders are provided from the arch-ribs to carry the roadway as shown in Fig. 6.14.

### Movable Bridges

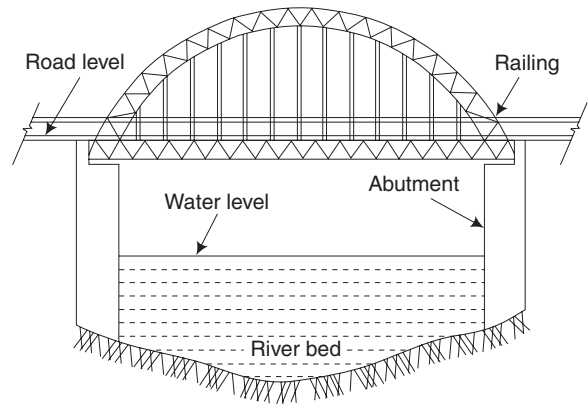
Movable bridges are constructed in order to provide a headway or opening for navigation ships. The design of the bridge superstructure is done in such a way that it can be moved so as to allow necessary width and clearance for the passing of ships. The following are the common types of movable bridges:

1. Vertical lift bridge
2. Bascule bridge
3. Swing bridge

1. *Vertical Lift Bridge* In such bridges, the trusses supporting the roadway are vertically lifted up by means of cables operated by electric motors or hydraulic machines.

2. *Bascule Bridge* Bascule type bridge is one in which the bridge can be opened vertically upwards. The bridge may be of single bascule or double bascule. The railway bridge connecting the Mandapam and Rameswaram island, is of double bascule type.

3. *Swing Bridge* In the case of swing bridges, the trusses carrying the roadways revolve about a vertical axis whenever required.



**Fig. 6.14** Steel bow-string girder bridge

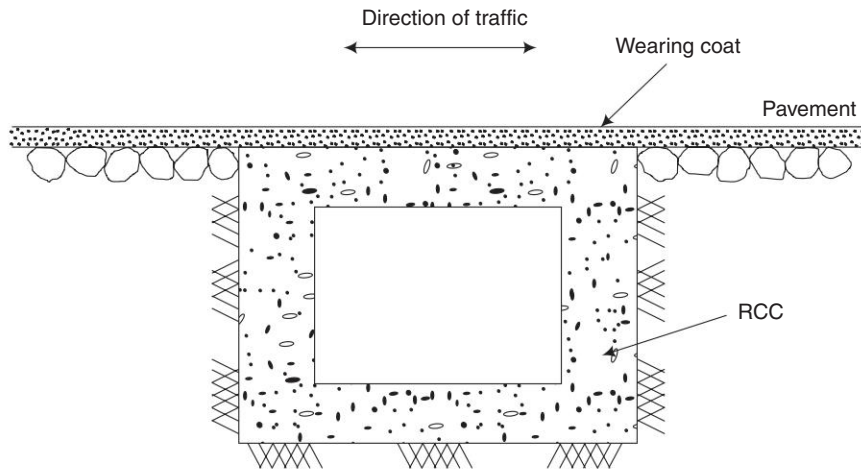
## 6.8 CULVERTS

A culvert is a drain or water course totally enclosed and usually carried under a road or railway track. The following are the common types of culverts.

- (a) Box culvert
- (b) Pipe culvert
- (c) Arch culvert

### 6.8.1 Box Culvert

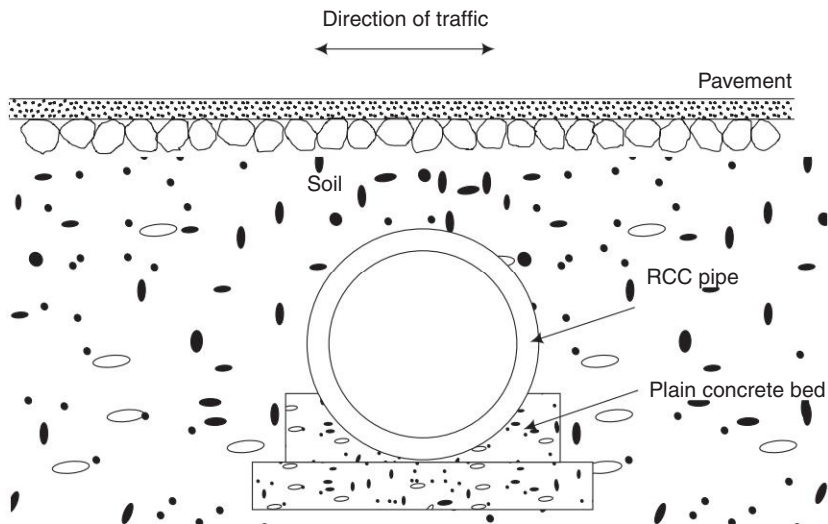
A box culvert consists of one or more square or rectangular openings made of RCC or masonry but RCC box culverts are used widely. Box culverts are used for spans less than 4 m. An RCC box culvert is a cheaper alternative for a pipe culvert. The abutments, top and bottom slabs are all cast monolithically. A box culvert is shown in Fig. 6.15.



**Fig. 6.15** *Box culvert*

### 6.8.2 Pipe Culvert

Pipe culverts are most economical for small drainage crossings. These culverts are generally constructed for diameters less than 1.8 m. The pipes may be of cast iron or RCC. If the soil is of low bearing capacity, the pipes should be bedded in a layer of concrete. If the discharge of water is more, more than one pipe can be used. Figure 6.16 illustrates a pipe culvert.

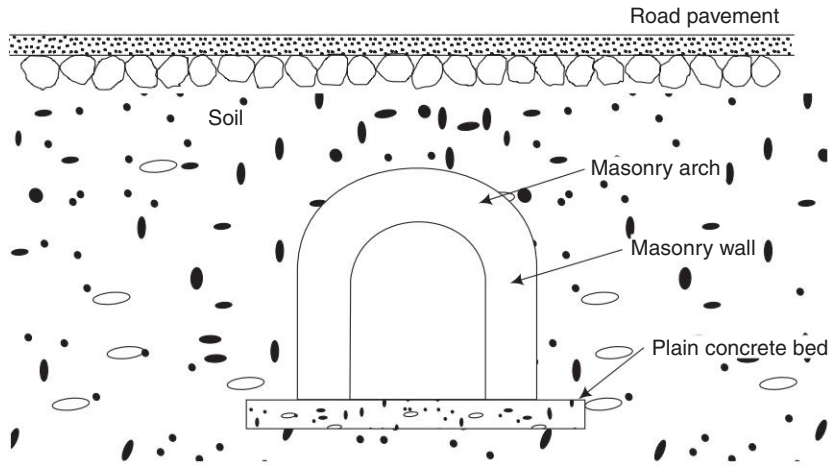


**Fig. 6.16** *Pipe culvert*

### 6.8.3 Arch Culvert

[May, June 2010]

Arch culverts are constructed on brick or stone masonry or concrete walls having short spans of 2–3 m. Depending upon the loading, span and type of construction, the thickness of an arch may be of 20–50 cm. Above the crown of an arch, an earth cushion of at least 45 cm should be provided as shown in Fig. 6.17.



**Fig. 6.17** Arch culvert

## 6.9 CAUSEWAYS

Causeways are constructed when they are preferred to a regular bridge under the following circumstances.

- (i) The river carries very little water and the water is spread over a wide area. Also, when there is no water in the river during a substantial part of the year.
- (ii) There is high flood discharge only occasionally and that too for a short period of time.
- (iii) Funds, materials and facilities are not available for the construction of a regular bridge.
- (iv) Traffic which uses crossing is light and insignificant.

Causeways are divided into the following three classes.

- (a) Flush causeways
- (b) Causeways with vents
- (c) High level causeways (also called as submersible bridges)

### 6.9.1 Flush Causeways

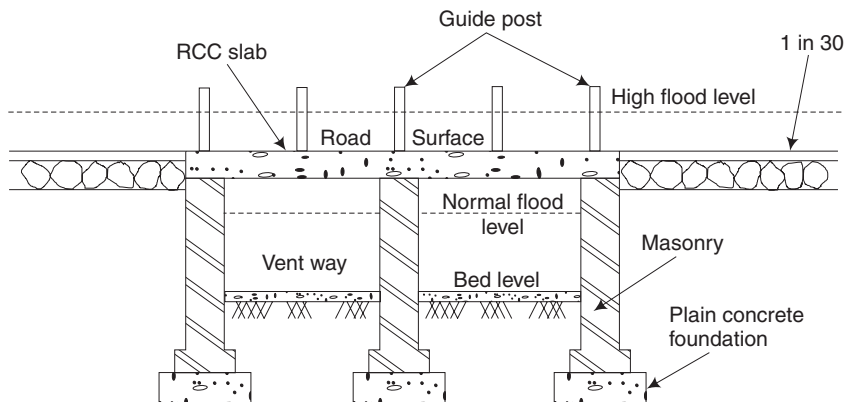
A flush causeway is a low level causeway. In this type, the pavement for the traffic may be at the bed level of the stream itself. There is no vent or opening underneath. For the construction of the pavement, a cement concrete slab of 10 cm thickness may be laid over 25 cm thick random rubble course in lime mortar.

### 6.9.2 Causeways with Vents

In this type of causeway, water flows through a number of box-type or circular openings or vents. The level of the road is fixed in a way such that it can be used even during the rainy seasons. During high floods, the road will submerge.

### 6.9.3 High-Level Causeways

These are bridge structures constructed with vents. They will submerge only during occasional high floods. IRC code of practice recommends this type of bridge for places where the flood level above the road surface is not more than three days at a time or six times in a year. The total interruption to the traffic being restricted to 15 days in a year. This type of structure is particularly suitable when the river width is small, normal flow is continuous and the difference between the highest flood level and ordinary flood level is so large that the construction of a regular bridge is uneconomical. Since this structure is similar to a bridge and is submerged during high floods, it is called a *submersible bridge*. The longitudinal section of a high-level causeway is shown in Fig. 6.18.



**Fig. 6.18** A high-level causeway

**Short-Answer Questions**

1. What is the difference between a pier and abutment?
2. Differentiate between deck bridge and through bridge.
3. What is a slab bridge?
4. How are bridges classified according to the span?
5. What is meant by an overbridge?
6. How are bridges classified according to the loading?
7. What is the function of the following in bridges:  
(a) Wing wall      (b) Bearings
8. What are viaducts?
9. Mention the commonly used steel truss bridges which are commonly used.
10. Why are heavy abutments not required in steel rigid-frame bridge?
11. What is the reason for using plate-girder bridges for railways?
12. What are the types of steel arches?
13. What is the function of suspenders and steel tie, in the steel bow-string girder bridges?
14. What are the common types of movable bridges?
15. How are culverts classified on the basis of shape?
16. Under what circumstances are causeways constructed?
17. List out the types of causeways.



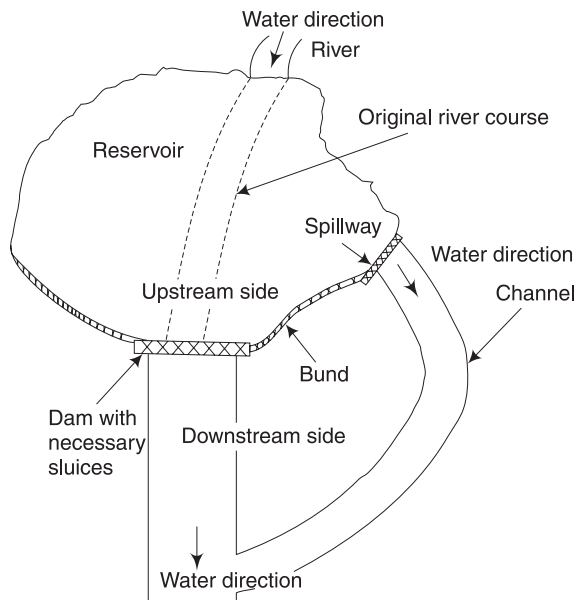
# Chapter 7

## DAMS

### 7.1 INTRODUCTION

[Apr, May 2015, Regulation 2008]

A dam can be defined as an impervious barrier or an obstruction constructed across a natural stream or a river to hold up water on one side of it, up to a certain level. As shown in Fig. 7.1, the side on which water is getting stored is called *upstream side* and the other side is called the *downstream side*. The stored water on the upstream side constitutes the reservoir. Sluice means the passage of water from upstream side to downstream side.



**Fig. 7.1** *General layout of a dam*

## 7.2 PURPOSE OF DAMS

[Nov, Dec 2011]

The construction of a dam across a river results in the ponding of water on its upstream side and this serves many useful purposes for mankind. They are as follows:

1. The stored water in the dam can be conveniently used for irrigation purposes.
2. The reservoir forms a very good source for water supply in areas where groundwater source is inadequate.
3. If sufficient head of water is stored, then that can be used for power generation (hydel power).
4. In case of heavy floods, if water is left unobstructed, the result will be very hazardous involving irrecoverable loss of lives of human beings, animals, etc., and loss of property. A dam across the river can act as a good flood-control measure by only letting out the excess quantity of water.
5. A dam with its green surroundings forms an excellent place for recreation purposes such as boating, swimming and water skiing.
6. The reservoir forms a good place for the breeding of fish, which is a considerable wealth from dam. Fish are bred by the pisciculture department.
7. Besides the above-mentioned purposes, a dam serves many miscellaneous purposes, such as adding beauty to the place where it is located and making it a place of tourism importance. The atmospheric heat around the reservoir and its surroundings is controlled well due to the large exposed area of water in the reservoir.

## 7.3 COMPONENTS OF A RESERVOIR

1. A dam across a river/valley forms a pool of water on the upstream side with necessary sluices to let out water.
2. Irrigation canals taking off from one/either side of the dam with necessary outlets to control the flow in the canal.
3. Spillway to let out the excess water from the dam which otherwise may result in breach of the dam itself due to overstorage of water. Therefore, the spillway acts as a safety valve of the dam.
4. A good earthen bond in case of a totally artificially made reservoir.
5. Ancillary works like fish ladder, log chutes, etc.

## 7.4 SELECTION OF SITE

[Nov, Dec 2014; Apr, May 2015, Regulation 2008]

The selection of a suitable site for a concrete dam depends on many factors, which are detailed below.

**Availability and Characteristics of Materials for Construction** It is necessary for economic consideration that the materials required for the dam should be available in close vicinity to the site. For a concrete dam, if natural material or good rock for making the aggregates

is available, it is desirable. If limestone is available nearby, it may be possible to replace Portland cement partially or wholly.

**Availability of Suitable Site for Construction Facilities** The dam site should offer a suitable place for location of colonies, etc. It is necessary to connect the dam site to the nearest rail head by a good road and also if economically feasible, by railway to transport construction machinery, hydromechanical equipment and subsequently for development.

**Availability of Utility Services** It is economical if the site has, in its near vicinity, an access road, electric line, and water supply, etc.

**Climate** Very cold and heavy rainfall will impede the progress of construction activities.

**Diversion During Construction** Sometimes river diversion problems play an important role in the selection of a dam site. This factor may affect the design of the dam and also the construction schedule.

**Foundation** The site should preferably have good sound rock for foundation. For a concrete or masonry dam, solid rock at the surface or within a reasonable depth below it, is essential. For arch dams, strong abutments are essential.

**Flood Control Aspect** The dam site should be above the area to be protected.

**Availability of Water** It is an important factor. Good water availability with minimum fluctuations is a desirable feature.

**Irrigation Command** The dam site should be above the area to be irrigated.

**Locality** Healthy surroundings free from mosquitoes are preferable.

**Sediment Load** An assurance that the dam would not silt soon is a desirable factor. The sediment load in the stream should be as little as possible.

**Spillway Site** In the case of a masonry dam, it is not essential that a good site for spillway be available. If available, it will be advantageous.

**Submergence** The value of the property and land submerged by the proposed dam should be low in comparison to the benefits expected from the dam. For example, the height of Rihand dam in Uttar Pradesh (India) could not be raised as the neighbouring Singarelli coal mines are under danger of being submerged.

**Topography and Storage Capacity** For the economic feasibility of a storage project it is necessary that the length of the barrier or dam should be as small as possible and for a given height, it should store a good volume of water. Hence the river valley at the dam site should be as narrow as possible and should open out upstream to provide a reservoir as shown in Fig. 7.1.

## 7.5 CLASSIFICATION OF DAMS

[Nov, Dec 2009; May, June 2011]

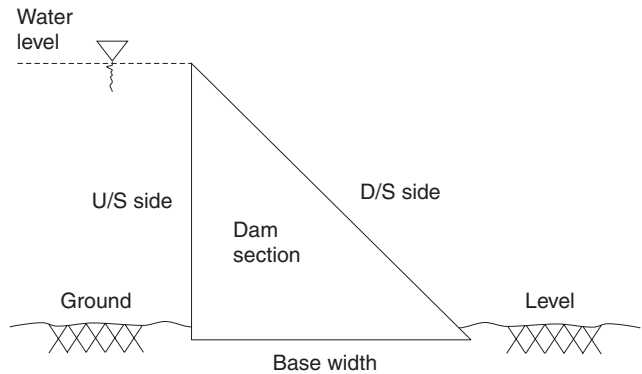
Dams are broadly classified into two categories—*rigid dams* and *non-rigid dams*.

### 7.5.1 Rigid Dams and their Types

As the name implies, these dams are constructed using rigid construction materials, such as stone or brick or reinforced cement concrete or plain cement concrete. The basic cross-sectional profile of a rigid dam is triangular as shown in Fig. 7.2. Various types of rigid dams are discussed below.

#### 1. Solid gravity dams

[May, June 2011, 2014]

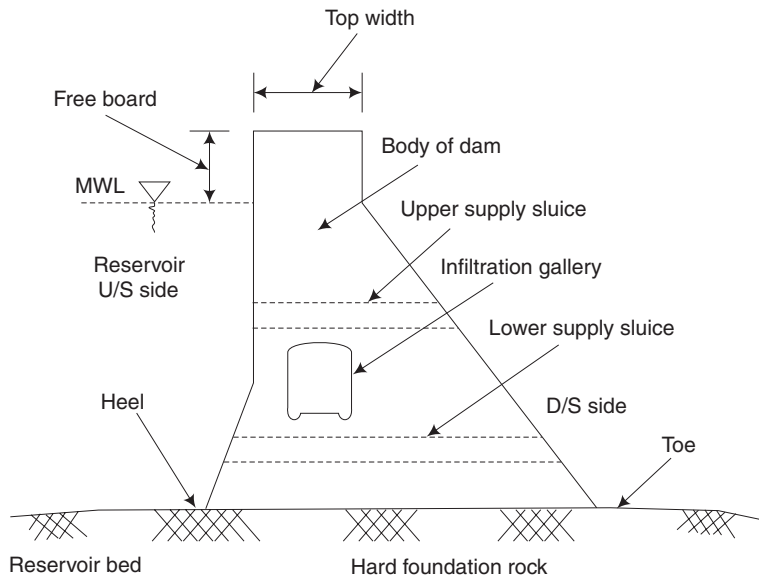


**Fig. 7.2** Basic profile of a dam

A gravity dam can be defined as a structure which is designed in such a way that its own weight resists the external forces. This type of dam is more durable and has maximum rigidity. It requires less maintenance when compared to other types. This type can be constructed of masonry or concrete. Nowadays, concrete gravity dams are prevalent.

The dam section is massive as the self-weight is the only force which is going to resist all other disturbing forces acting on the dam. Therefore, it needs a good foundation soil, preferably a rocky strata.

In practice, a triangular basic profile cannot be adopted and instead this profile is modified to accommodate the operating platform for the shutters and roadway at the top. So a practical profile will be a trapezoidal one with a sufficient free board as shown in Fig. 7.3.



**Fig. 7.3** Cross-section of a gravity dam

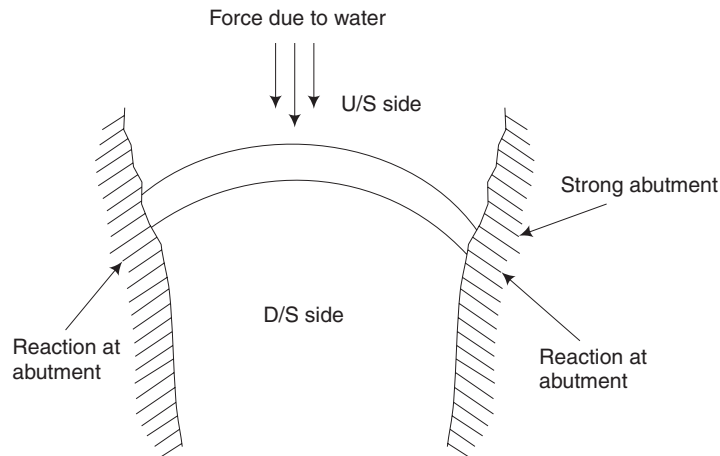
The water stored on the upstream side exerts a major disturbing force on the dam. In addition to this, water may seep through the body of the dam and below the foundation of the dam. This will cause uplift of the dam which also affects the stability of the dam. There are also wave pressure, ice pressure, pressure due to earthquake forces, etc., affecting the stability of the dam. Of the above, pressure due to earthquake is significant and this has been the major cause for serious cracks in several dams.

To relieve the uplift pressure in the dam, infiltration gallery is provided within the dam section. This will collect the seeping water and will convey it to greater depth so as not to affect the stability of the dam.

The provision of supply sluice controlled by shutters enables the release of required quantity of water to the downstream side.

A gravity dam may fail due to overturning, sliding, and crushing at the toe. Generally, a gravity dam will be designed with a higher factor of safety and check will be made for the above possible failures.

**2. Arch dams** An arch dam is curved in plan with its convex face holding the water as shown in Fig. 7.4 (a). This structure is less massive when compared to the gravity dam. The force exerted by the stored water on the upstream side will be transferred to the abutments by the arch action.

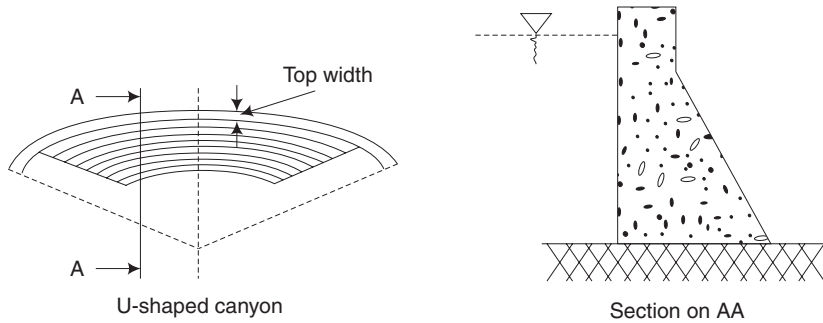


**Fig. 7.4(a)** Arch dam

This dam is suitable for narrow valleys but the major requirement is sound abutments. In this case, uplift on the base of the dam has no problem because only abutments are going to bear maximum force. An arch dam will be economical only if the length of the dam is less than its height. Therefore, this is preferable for very great heights.

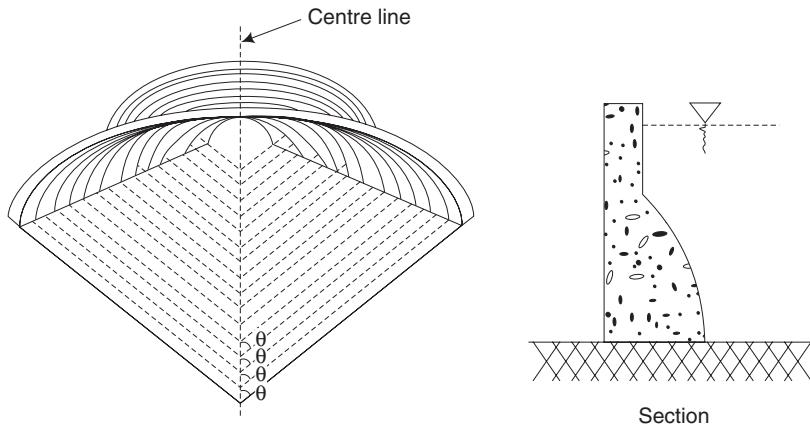
According to the method of construction, arch dams are classified into the following types.

(a) Constant-radius arch dam as shown in Fig. 7.4(b).



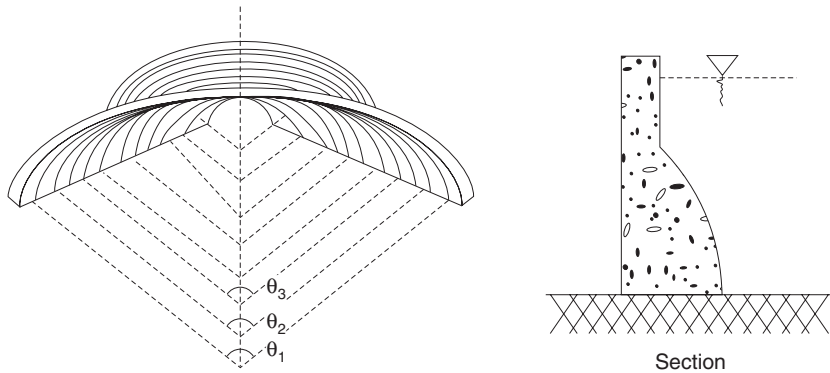
**Fig. 7.4(b)** *Constant-radius arch dam*

(b) Constant-angle arch dam as shown in Fig. 7.4(c).



**Fig. 7.4(c)** *Constant-angle arch dam*

(c) Variable-radius and variable-angle arch dam as shown in Fig. 7.4(d).



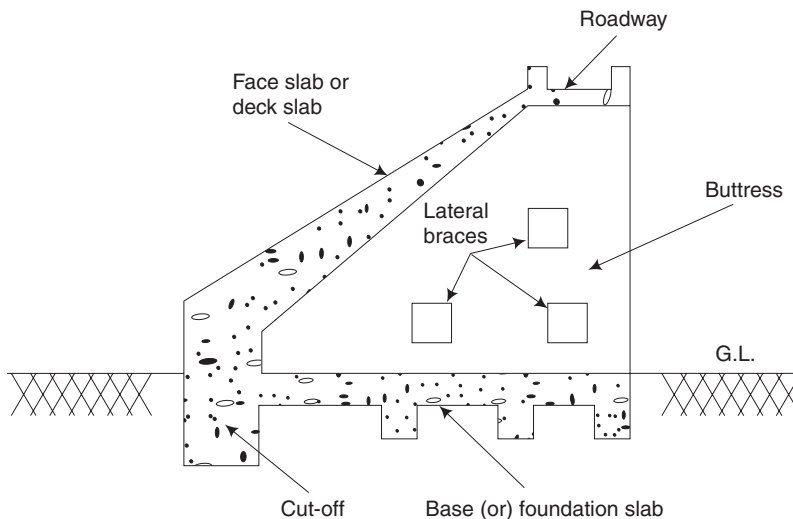
**Fig. 7.4(d)** Variable-angle and variable-radius arch dam

**3. Buttress dam** A buttress dam has relatively thin sections when compared to a gravity dam. Generally, it consists of a sloping section, buttresses and a base slab.

The sloping membrane (face slab) first takes the water load and transfers it to the buttresses which are at specific intervals. The buttresses in turn transfer the load to the base slab which forms the foundation part of the dam.

The important types are the flat slab type/ambursen type and the multiple arch type.

In the first case, between two buttresses, RCC slabs (reinforced cement concrete) will be available as detailed in Fig. 7.5. In the case of an arch buttress dam, the arch action of the slab permits wider spacing of buttresses. Lateral beams called braces or struts will be provided between buttresses along the length of the dam which provide additional strength to the buttresses.

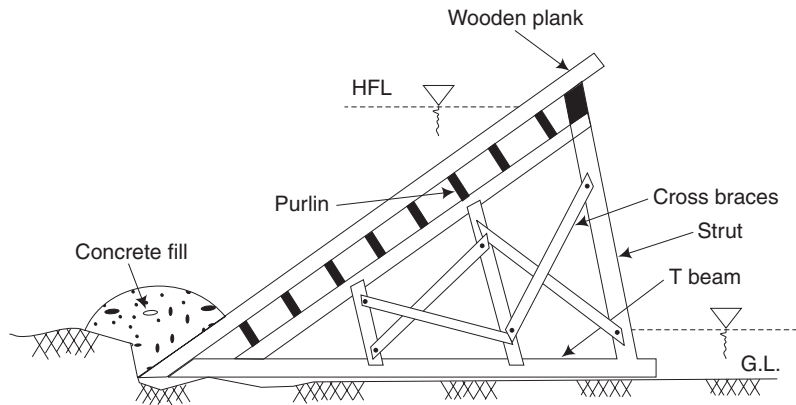


**Fig. 7.5** Section of an RCC buttress dam

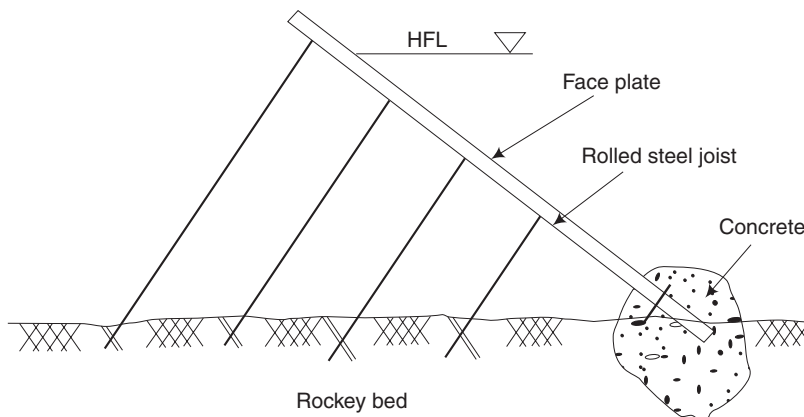
The height of buttress dams can be conveniently increased by mere extension of buttresses and face slabs. Buttress dams are less massive and can be constructed where the foundation soil is relatively weak. Enormous space available between buttresses can be advantageously used for installing water-treatment plants and powerhouses.

**4. Timber and steel dams** Timber dams (shown in Fig. 7.6) and steel dams (shown in Fig. 7.7) are special types which are not generally used for bigger dam sections.

A timber dam is generally adopted for temporary requirements to enclose certain work sites or to divert the flow to enable the construction of the main dam. After the main structure is built, generally the timber dam will be dismantled. The height of the dam may be up to 9 metres. Timber dams are rarely made watertight. Steel dams are not common in use. But it is possible to construct the dam with steel up to a height of 15–18 m. The construction of a steel dam may be done similar to the timber dams.



**Fig. 7.6** *Buttress-type timber dam*



**Fig. 7.7** *Section of a steel dam*



### 7.5.2 Non-rigid Dams

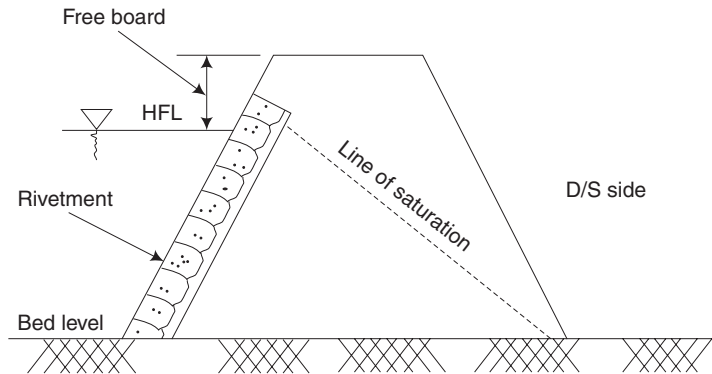
Non-rigid dams have a trapezoidal basic profile. Earth dams and rock-fill dams which fall under this category are discussed in this section.

**1. Earth dams** Earth dams are made of soil with minimum processing using primitive equipment. These are built in areas where the foundation is not strong enough to bear the weight of a gravity dam. As the construction material of this dam is ordinary soil which is cheaply available, the cost of construction will be less than that of a rigid dam. These can be constructed in places of low or moderate rainfall which necessitate only moderate heights for the dam.

The three different types of earth dams are described here.

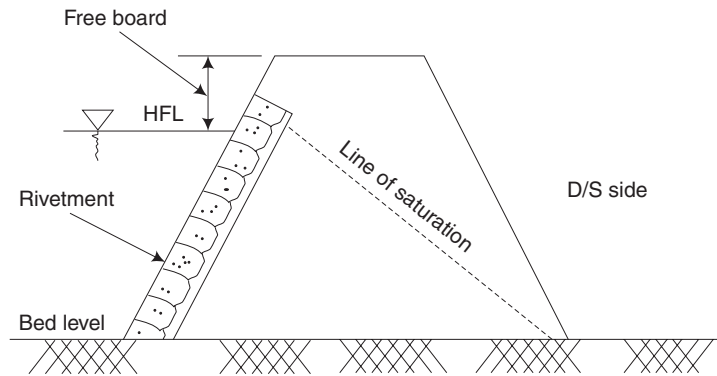
(a) *Homogeneous embankment type* When only one type of material is economically or locally available, such homogeneous embankments are possible. This is the simplest type of an earth dam consisting of a single material throughout the structure.

A purely homogeneous type poses the problem of seepage which is not desirable from the stability point of view. Sometimes stones will be pitched over the upstream face of the dam to safeguard the dam against wave action and to improve the stability as shown in Fig. 7.8.



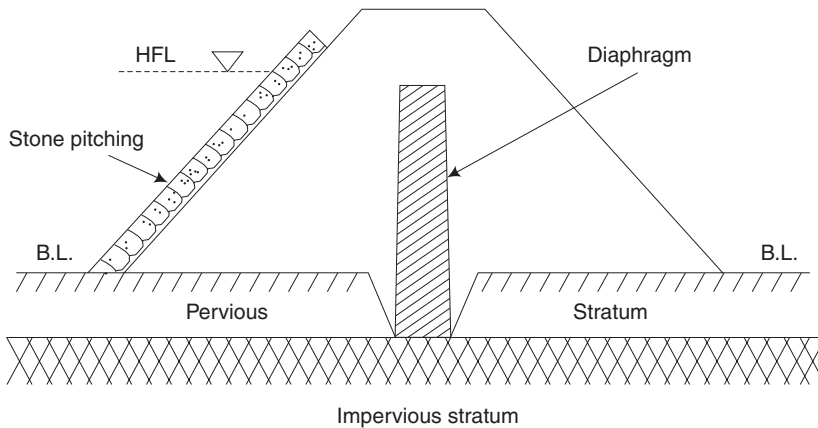
**Fig. 7.8** *Homogeneous earth dam*

(b) *Zoned embankment type* The section of a zoned embankment earth dam will have an inner zone made of impervious soil and an outer zone made of pervious soil as detailed in Fig. 7.9. Normally, inner zone will be of clay or silt or a mixture of both and the outer zone is of locally available soil. The presence of inner impervious zone provides added strength and reduces seepage of water through the dam section. This type can be adopted for dams of greater heights. A suitable filter medium in the form of transition filter combined with toe filter is provided. The provision of above filters will ensure proper collection of the water seeping through the dam section and conveyance of the collected water to the downstream side safely adds to the stability of the dam.



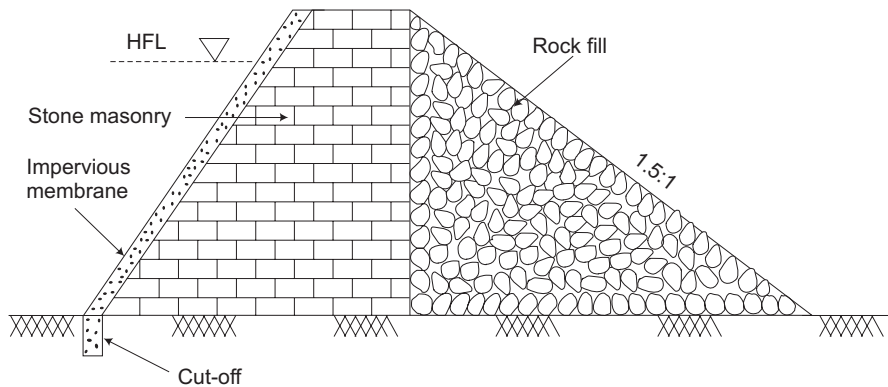
**Fig. 7.9** Zoned embankment type

(c) *Diaphragm-type embankments* These have a thin impervious core, which is surrounded by earth as shown in Fig. 7.10. The thin core is called the diaphragm and is usually made of impervious soils or concrete or steel or timber. The diaphragm must be tied to the bed rock or to a very impervious foundation material.



**Fig. 7.10** Diaphragm-type embankment

**2. Rock-fill dams** Rock-fill dams are made of loose rocks and boulders piled in the river bed. A slab of reinforced concrete is often laid on the upstream face to make it water tight. These are more stable than earthen dams and less stable than gravity dams. The dam section generally consists of dry rubble stone masonry on the upstream side and loose rock-fill on the downstream side as shown in Fig. 7.11.



**Fig. 7.11** Section of a rock-fill earth dam

Rock-fill dams are subjected to more settlement problems which may even result in the cracking of the reinforced concrete membrane on the upstream side. It has better resistance towards earthquakes because of its flexible nature. The structural design of this type of dam is bit complicated when compared to other types.

### 7.5.3 Gravity Dam

[Nov, Dec 2010]

#### Advantages

1. **Maximum Rigidity** A gravity dam has maximum rigidity, due to its heavy and solid self-weight. Hence, it is also named solid gravity dam.
2. **Durability** It is highly durable and requires minimum maintenance.
3. **Height of the Dam** It can be constructed of any height, provided a suitable foundation is available to withstand the loads on it.
4. **Stability** It is relatively stronger and more stable than earth dam.
5. **Use** A gravity dam is most suited at sites with narrow gorges or valleys and steep side slopes. It is adopted for use as an overflow dam.
6. **No sudden Failure** Failure of the gravity dam, if any, may not suddenly occur.

#### Disadvantages

1. **Rock Foundation** A gravity dam can be constructed only on sound rock foundations.
2. **Causes of Failure** A gravity dam may fail due to overturning or sliding or crushing, due to the heavy self-weight of the dam and the forces acting on it.
3. **Raising the Height** Unless specific provision is made in the initial design itself, it will be very difficult to raise the height of the dam subsequently.

4. **Initial Cost** Initial cost is higher than that of earth dams.
5. **Skilled Labour** Skilled labour is required for its construction.

#### **Advantages of Arch Dam**

1. The arch dam is suitable for narrow valleys or gorges.
2. The arch dam requires less construction materials and is hence less massive. Saving in the quantity of concrete is around 50% compared to gravity dam. This is because of its better structural effectiveness.
3. When the height of the dam is more than its length, an arch dam is economical. Therefore, this dam is preferable for very great heights.

#### **Advantages of R.C.C. Buttress Dam**

1. *Stability* Weight of water on the inclined face slab helps to maintain the stability of the dam. Because of this, the requirement of quantity of concrete becomes less. Thus, the dead weight of the dam is reduced.
2. *Weak soil* As the dead weight of the dam is less, it may be constructed in weak soil, where hard or rocky stratum is not available.
3. *Height of the dam* The height of a buttress dam can be easily increased by simply extending the buttress and the face slabs.
4. *Lateral beams( braces)* The braces add to the strength of the buttress.
5. *Space between Buttress* The space available between the buttress is very large. It may be used for housing water-treatment plants and power houses.

#### **Advantages of Embankment Earth Dams**

1. Embankment earth dams are suited to a wide variety of foundation conditions.
2. They are suitable for both steep gorges and wide valleys.
3. Local materials can be made use of.
4. Reduced cost of construction.
5. About 80% of the total number of dams in the world are earth dams.

## **7.6 GEOLOGICAL EFFECTS**

In the construction of dams, geology plays a vital role in site selection. The first consideration in all sites for a dam is the suitability of the rock in foundations. The main geological considerations in the selection of dam sites are as follows.

- (i) The underlying rocks must be strong enough to withstand the weight of the dam and the resultant thrust.
- (ii) The rocks should be sufficiently impervious to prevent seepage of water beneath the sole of the dam.
- (iii) The rocks should be free from fissures, joints and faults so that there is no leakage of water.

Sites which have an impervious band of strong massive rocks, free from joints throughout the length of the dam, are considered to be the best site for a dam. Granite which is free from joints and fissures would make an excellent foundation for any dam.

When a river breaks across a ridge by cutting a deep gorge at right angles to the strike off the bedded or foliated rocks, an ideal dam site may be found in the gorge.

In case of loose, unconsolidated strata like sand and loam where there is considerable loss by percolation or leakage, high dams cannot be efficiently constructed. In such areas, it is possible to construct low-pressure dams if they have sufficiently wide foundations without openings or crevices.

Across the fault plane it is not advisable to construct any dam. Rocks having small fissures and joints can be sealed with concreting material but still it is not reliable during earthquakes.

Massive solid rocks such as granite, quartzite, limestone and sandstone make excellent sites for the foundation of dams, if they are free from open joints and fissures. Decomposed rocks such as dolerite and laterite should be avoided, as there is a possibility of percolation of water.

### *Short-Answer Questions*

1. Distinguish rigid dams from non-rigid dams.
2. What are the components of a reservoir?
3. Give a general layout of a dam.
4. What is the purpose of providing a spillway in a dam?
5. What is the function of an infiltration gallery in a dam?
6. What are the common modes of failure of a gravity dam?
7. List out the classification of dams.
8. Why is a gravity dam so called?
9. Why are the lateral braces provided in the buttress dams?
10. What do you mean by filters in a non-rigid dam? What is the purpose of these filters?
11. Write short notes on geological effects on dams.

### *Exercises*

1. What is a dam and what are the components of a reservoir?
2. What are the factors based on which the site for a dam is selected? Explain them briefly.
3. What is the basic profile of a dam? How is the practical profile determined from the basic profile?

4. Draw a neat sketch of the cross-section of a dam and give the forces acting on it.
5. Explain the different types of arch dams.
6. Explain with sketches the various types of earthen dams.
7. What are the purposes of a dam?

**UNIT-4**

**INTERNAL COMBUSTION ENGINES  
AND POWER PLANTS**





# Chapter 8

## POWER PLANTS, GAS TURBINES AND ALTERNATE SOURCES OF ENERGY

### 8.1 INTRODUCTION

Power plants are used for the generation of electric power. To improve the standard of living, rapid industrialisation is necessary for which adequate electrical power is essential. In India, there has been considerable increase in power development under various five-year plans.

### 8.2 CLASSIFICATION OF POWER PLANTS

[Nov 2009, 2010, Regulation 2008; Nov 2014; Apr 2015, Regulation 2013]

Power plants can be mainly classified as follows:

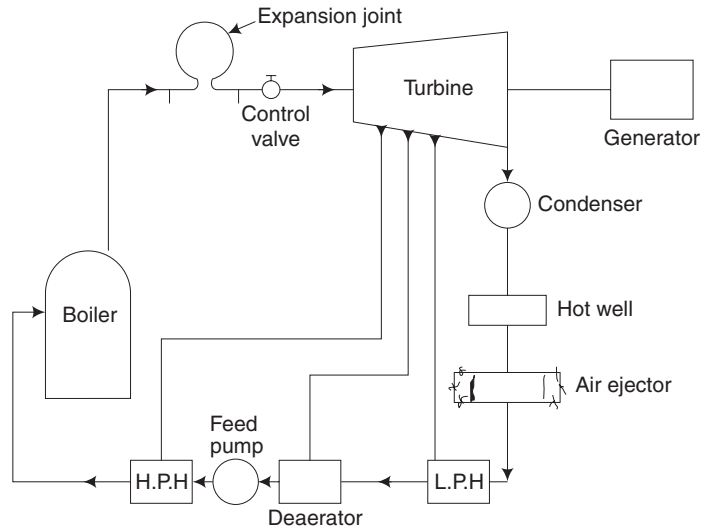
1. Steam power plant
2. Nuclear power plant
3. Gas-turbine power plant
4. Diesel power plant
5. Hydroelectric power plant
6. Power from alternate sources of energy

In the remaining part of this chapter, a description of the above power plants and alternate sources of energy is provided.

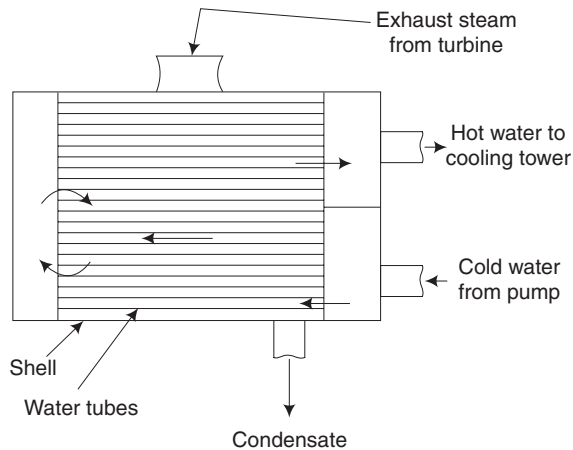
### 8.3 STEAM POWER PLANTS

[Nov 2009, 2010; May 2013; Apr 2015, Regulation 2008; Apr 2015, Regulation 2013]

The layout of a steam power plant is given in Fig. 8.1(a). Steam from the boiler is taken to the turbine through the steam pipe fitted with an *expansion joint*. The joint provides a *flexible connection to prevent any crack* in the steam pipe which is subjected to expansion and contraction due to the variation of temperature. From the turbine, the steam enters a condenser, details of which are shown in Fig. 8.1(b). In the condenser, *the exhaust steam from the turbine is condensed due to which a high vacuum is produced*. Due to the vacuum, *the power output and the thermal efficiency of the turbine are considerably increased*. Also, *the condensed water can be recirculated in the system*. In the condenser, cooling water is circulated by a pump through the water tubes to condense the exhaust steam. The cooling water at



**Fig. 8.1(a)** Layout of a steam power plant



**Fig. 8.1(b)** 2-Pass steam condenser

the outlet becomes hot and it is taken to a cooling pond or a cooling tower to cool and to recirculate the same water if the power plant is not located on the bank of a river or a lake.

The condensate from the condenser before entering the boiler is subjected to the following treatments.

1. Removal of air and oxygen.
2. Preheating the feed water in different stages using a low-pressure heater (LPH), a deaerator and a high-pressure heater (HPH).

*Air and oxygen are removed at the air ejector and the deaerator. In case air and oxygen are not removed from the feed water, the vacuum cannot be maintained in the condenser, resulting in loss of power and thermal efficiency.*

### 8.3.1 Different Circuits of a Steam Power Plant

[May 2012, Regulation 2008]

Layout of the steam power plant can be split to the convenience of the readers in terms of different circuits. List of different circuits and the main components or equipment in the respective circuits are as follows:

1. *Coal and ash circuit:* Coal and ash circuit comprises of a coal supply dump, coal conveyer, pulverizer, pulverized coal feed arrangement to the boiler, radiant zone of the boiler, electrostatic precipitator, fly ash handling system and the chimney.
2. *Air and gas circuit:* Air and gas circuit consists of a blower, air pre-heater, radiant zone of the boiler (water walls to boil the water and the super heater are placed here), water pre-heater, economizer, electrostatic precipitator and the chimney.
3. *Feed water and steam flow circuit:* Feed water and steam flow circuit comprises the feed water treatment plant (water softening plant and deaerator), feed pump, water pre-heater/economizer, radiant zone of the boiler (water walls to boil the water and the super heater are placed here), turbine, condenser, water heaters and pumps.
4. *Cooling water circuit:* Cooling water circuit consists of condenser, cooling tower, hot well, pump, makeup water supply from river or pond and intake filter system.

### 8.3.2 Factors to be Considered in the Selection of a Site for a Steam Power Plant

1. The location of the plant should be at a minimum distance from the load centre (consumer) to avoid transmission losses.
2. Availability of water is a desirable factor.
3. The water should be preferably free from salt to reduce the cost for water treatment.
4. The soil should be satisfactory for a strong foundation.
5. The site should be away from thickly populated areas to reduce the effect of pollution.
6. Adequate transport facility is desirable.
7. Space should be available to store coal and ash.

## 8.4 NUCLEAR POWER PLANT

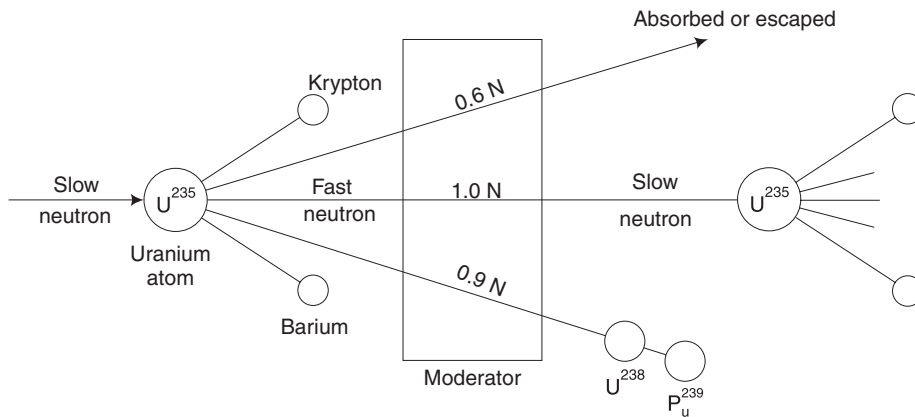
[May 2014, Apr 2015, Regulation 2008]

A nuclear power plant is very similar to a conventional steam power plant except for the furnace. The nuclear reactor becomes the furnace in this case. It has been estimated that complete fission of 1 kg of uranium  $U^{235}$  produces heat energy equivalent to 4500 tons of coal or 1700 tons of oil.

**Dalton's Atomic Theory** Earlier, Dalton, an English scientist, discovered that an element is made up of extremely small particles called atoms. An atom is the smallest particle of an element. According to Dalton's theory, an atom cannot be split. But this theory is no longer valid.

**Nuclear Fission** Contrary to the Dalton's Atomic Theory, it has now been established that a large amount of heat energy is derived by fissioning of the nucleus of a fissionable material like uranium  $U^{235}$ . When a neutron bombards the nucleus of  $U^{235}$ , the atom splits into krypton and barium and releases 2.47 fast moving neutrons and also produces a large amount of heat energy.

As in Fig. 8.1(c), one of the neutrons released during the fission continues to fission another nucleus of  $U^{235}$  causing a chain reaction which produces enormous amount of heat energy. About 0.9 neutron is captured by  $U^{235}$  which gets converted into fissionable material  $PU^{239}$  and about 0.6 neutrons is partly absorbed by the moderator and a part escapes from the reactor.  $PU^{239}$  is a fissionable material and is called *secondary nuclear fuel*.

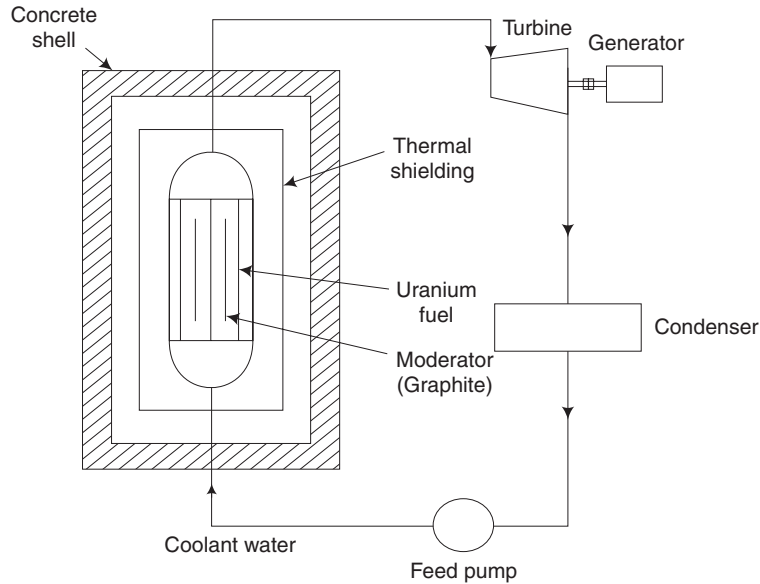


**Fig. 8.1(c)** Nuclear reaction

### 8.4.1 Boiling Water Reactor

A simple boiling water reactor is shown in Fig. 8.1(d). Due to nuclear fission of the *fuel uranium*, large amount of heat is produced. The nuclear reaction and thereby the *temperature is controlled by moderators*. The coolant used here is water which absorbs the heat produced in the reactor. Water evaporates and *steam is generated in the reactor itself*. In this type of power plant, there is no need for a separate boiler.

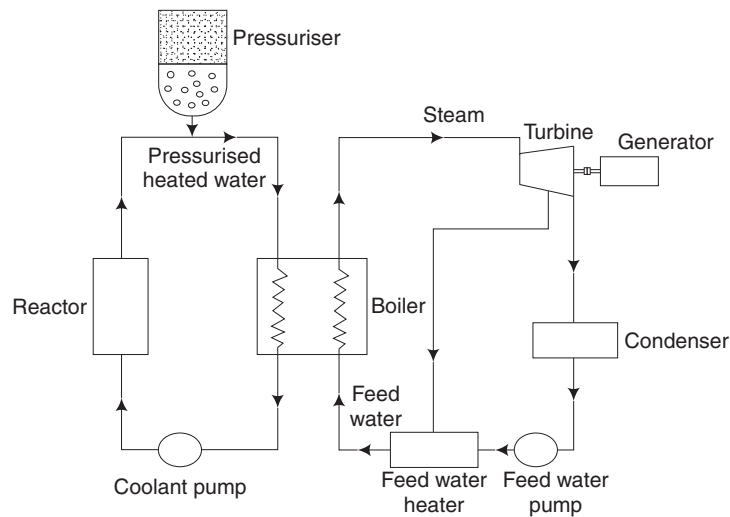
The steam produced in the reactor is used to run the turbine coupled with a generator from which we get the electrical power. The steam after expansion in the turbine is condensed in the condenser. *The condensate after getting heated in several feed water heaters is pumped again into the reactor by means of a feed pump*. In the reactor, the *thermal shielding reduces the heat loss and the thick concrete shielding prevents external radiation*.



**Fig. 8.1(d)** *Boiling water reactor*

### 8.4.2 Pressurised Water Reactor (PWR)

The schematic diagram of a pressurised water reactor is shown in Fig. 8.2(a). It is also a water-cooled reactor. The system has primary and secondary loops. In the primary loop, the pressuriser maintains a high pressure in the water in the range of 150 bar. Due to the high pressure of water in the reactor, the water does not boil. The coolant gets heated in



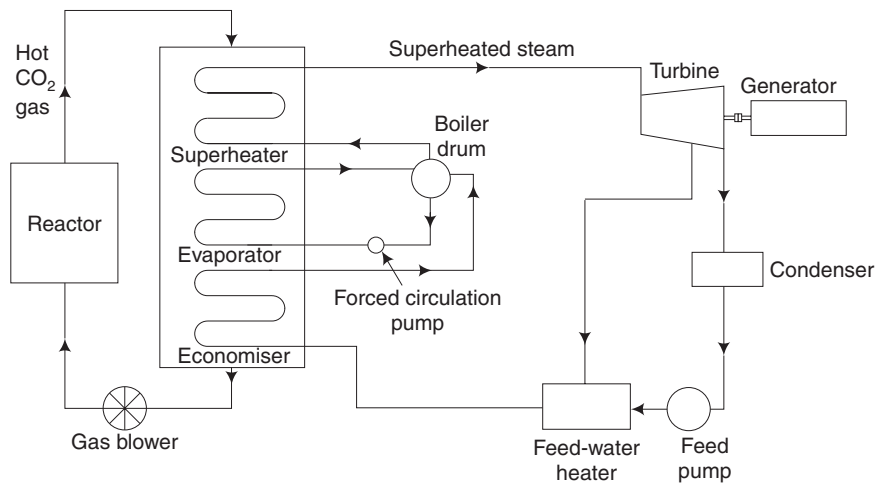
**Fig. 8.2(a)** *Pressurised water reactor*

the reactor and the hot water goes to the boiler and transfers the heat to the feed water in the boiler in the secondary loop. The feed water evaporates and becomes steam and runs a turbogenerator from which power is obtained. Functions of various parts of the reactor are the same as those of a boiling water reactor.

### 8.4.3 Gas-Cooled Reactor

The schematic diagram of a gas-cooled reactor is shown in Fig. 8.2(b). In this,  $\text{CO}_2$  is employed as coolant and the heat carried by the gas from the reactor is either used for steam generation in the secondary circuit like pressurised water reactor or is directly used as the working fluid in a gas-turbine plant. Usually, the gas used is  $\text{CO}_2$  and graphite is the moderator.

$\text{CO}_2$  gas gets heated in the reactor and loses its heat to the superheater, evaporator and economiser tubes in the secondary loop. The cooled gas is recirculated again in the primary loop by means of a gas blower. The superheated steam is expanded in the turbine to run the generator to produce electrical power.



**Fig. 8.2(b)** Gas-cooled reactor

### 8.4.4 Safety Precautions for Nuclear Power Plant

The first level of safety in nuclear reactor is the careful design of the reactor and other components of the system with a high degree of reliability, and the chances of malfunction are very small. Apart from the controlling devices like control rods, moderator and coolant in the reactor, some auxiliary safety devices are also provided.

When the primary protection system fails, each reactor is provided with some type of back-up protection. One important device is *gas fuse*. The gas used is boron trifluoride. This is filled in a container at high pressure and sealed with a plug which melts when the temperature in the reactor exceeds the safe value. If the temperature rises above the safe

value, sufficient volume of gas enters the reactor core and reactivity decreases, due to which the temperature automatically comes down.

#### 8.4.5 Nuclear Waste Disposal

The radioactive wastes produced in different stages of nuclear fuel cycle must be disposed off without any hazard to human and plant life. Gaseous wastes are discharged to the atmosphere through high stacks. Moderate liquid wastes, after a preliminary treatment are discharged into deep pits. Active liquids are kept in concrete tanks. These tanks are buried in the ground till their radioactivity decays up to a safe level for disposal.

#### 8.4.6 Advantages of a Nuclear Power Plant

[May 2012, Regulation 2008]

1. Very large amount of heat is liberated by a very small quantity of fuel.
2. It is suitable for large power generation.
3. Cost of fuel transportation and storage is less.

#### 8.4.7 Disadvantages

[May 2012, Regulation 2008]

1. Installation cost is very high.
2. Availability of nuclear fuel is scarce and cost is high.
3. Large number of trained and qualified personnel are required to operate the plant.
4. Maintenance cost is higher.
5. Problems are involved in waste disposal and there is also a risk of radiation hazards.

#### 8.4.8 Atomic Power Stations in India

1. The Tarapur Atomic Power Station in Maharashtra was initially constructed with two boiling water reactors of 160 MW, each under the agreement between India, the United States and the International Atomic Energy Agency. These were the first of their kind in Asia. Recently, an additional two units of 540 MW each have been constructed.
2. The Madras Atomic Power Station at Kalpakkam, about 80 km south of Chennai has two units producing 170 MW each, operative from 1984 and 1986 respectively. Additional reactors are under construction with a capacity of 500 MW. This station has been named as the Indira Gandhi Centre for Atomic Research (IGCAR). So, in addition to power production, the station is engaged in active research and development.
3. The Koodenkulam Nuclear Power Plant is under construction in the Tirunelveli district of Tamil Nadu with an agreement with the Soviet Union and will have 8 units with the total capacity of 9200 MW. When completed, they will become the largest nuclear-power generation complex in India. In December 2014, the first Unit, with 1000 MW capacity has started power generation and has been connected to the southern grid. Nuclear Power Project Unit-2 (KKNPP-2) with 1,000 MW

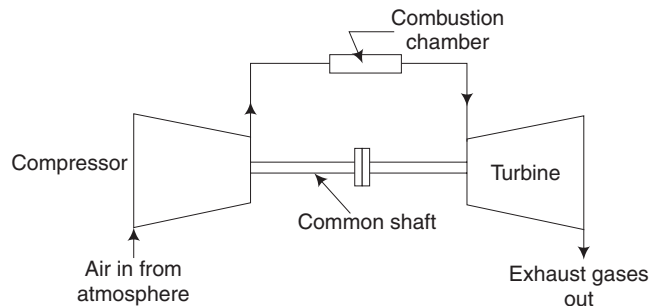
capacity is under commissioning. This would take around two-and-a-half years to design, fabricate, test and deliver at the site. Project cost is estimated at around Rs 39,000 crores. These are mainly nuclear steam supply systems. The units 3 and 4 of the Kudankulam Nuclear Power Project (KKNPP) with  $2 \times 1000$  MW capacity is being prepared. The Government has a target of increasing the nuclear power capacity of 4780 MW in the next ten years viz. 2024.

## 8.5 GAS TURBINES

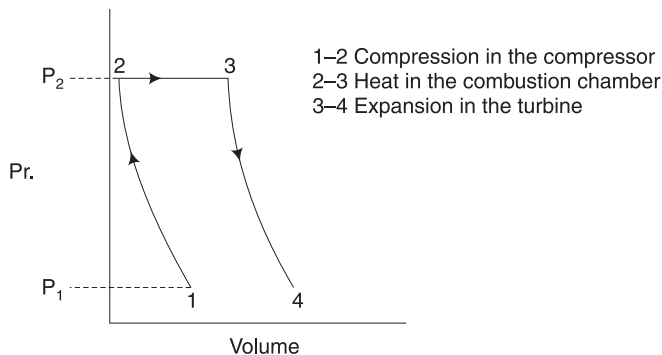
Gas turbines are used mainly for electric-power generation and also in jet engines of aircraft and in turbochargers of internal combustion (IC) engines. They have limited application in marine engines. Gas turbines have the unique advantage of using any type of fuel, i.e., solid, liquid or gas. Gas turbines operate either on an open cycle or in a closed cycle.

### 8.5.1 Working of an Open-Cycle Single-Stage Gas Turbine

A simple open-cycle gas turbine is represented in Fig. 8.3(a). It consists of a compressor, a combustion chamber and a turbine. The compressor and turbine are connected by a common shaft with a suitable flange. Air from the atmosphere is taken and compressed to a pressure ratio ranging from 2–8 before passing to the combustion chamber where the fuel is injected. The fuel burns and the temperature is raised at constant pressure. Then, it passes to the turbine where it expands to its original pressure before being exhausted to the atmosphere. A major portion of the power developed in the turbine is used to drive the compressor and the remainder is available as the net power output. A simple gas turbine works on a Brayton Joule cycle as shown in Fig. 8.3 (b).



**Fig. 8.3(a)** Simple gas turbine



**Fig. 8.3(b)** Brayton Joule cycle



### Advantages of Gas Turbines

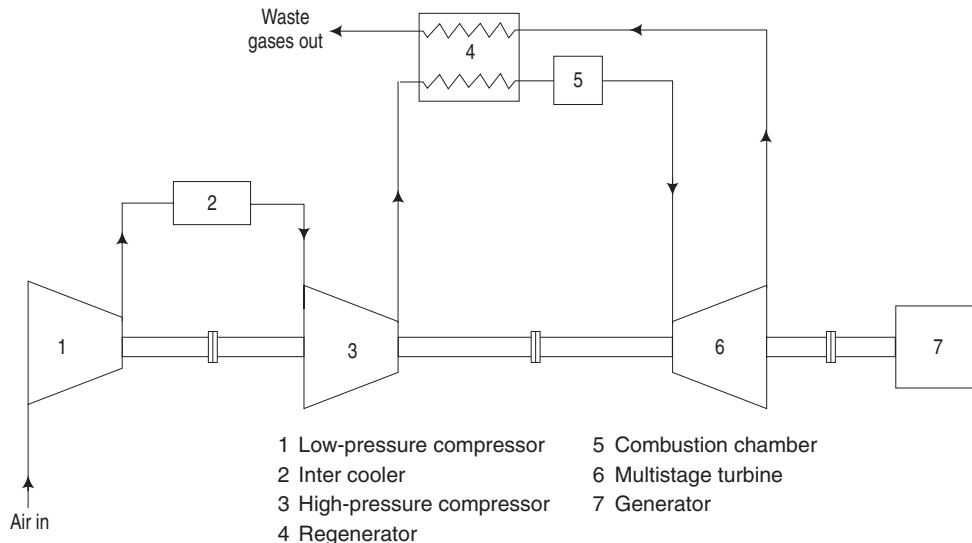
1. Possibility of using any type of fuel.
2. Compact size, less weight and low space requirement.
3. Simple foundation and low installation cost.
4. Less requirement of lubrication oil, water, etc.
5. Less vibration.

### Disadvantages of Gas Turbines

1. There is high operating temperature in the combustion chamber and in the turbine. So, we need special high-temperature alloys.
2. Thermal efficiency is very low in the case of simple gas turbine due to high temperature of about  $450^{\circ}\text{C}$  in the waste exhaust gases. So, a single-stage gas turbine is not suitable for electric-power generation.
3. It exudes high-pitch noise due to very high speed in the order of 50,000 rpm.
4. Gas turbines are not suitable for low capacity. In the world market, experimental gas turbines are available operating on a single stage giving an output of 45 kW. Such a turbine can only give the maximum thermal efficiency of about 6 per cent.
5. Large-size exhaust duct due to increased requirement of air for combustion and also for cooling.

### Methods to Improve the Thermal Efficiency of Gas Turbines in Power Plants

1. By using a multistage compressor with intercooling to reduce the work of compression, as in Fig. 8.4.

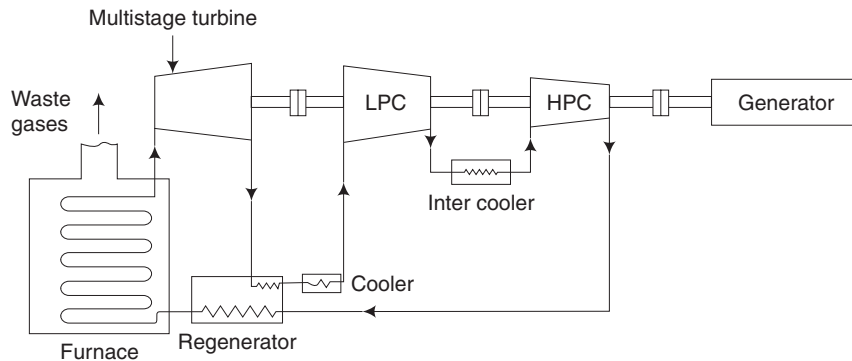


**Fig. 8.4** *Multistage turbine*

2. By using a multistage turbine to reduce the temperature of exhaust gases before leaving the turbine.
3. By using a regenerator, to further reduce the temperature of waste gases.

### 8.5.2 Closed-Cycle Gas Turbine

The closed-cycle plant can use some stable gas with a higher specific heat as the working medium. Instead of burning the fuel directly in the air stream, an externally fired combustion chamber or furnace is used and heat is transferred to the working medium through a heat exchanger as in Fig. 8.5. Thus, the working medium is uncontaminated by the products of combustion and is constantly recirculated. A cooler is provided for the recirculated working medium before it enters the low-pressure compressor in order to minimise the compressor work. Similarly, an intercooler is also provided to improve the overall efficiency of compression. As a multistage turbine is used, the temperature of exhaust gases leaving the turbine is considerably reduced resulting in a higher thermal efficiency. The regenerator preheats the gas before entering the furnace. By these provisions, the thermal efficiency is further increased to about 30 per cent.



**Fig. 8.5** *Closed-cycle gas-turbine plant*

The closed cycle gas-turbine plant has the following advantages:

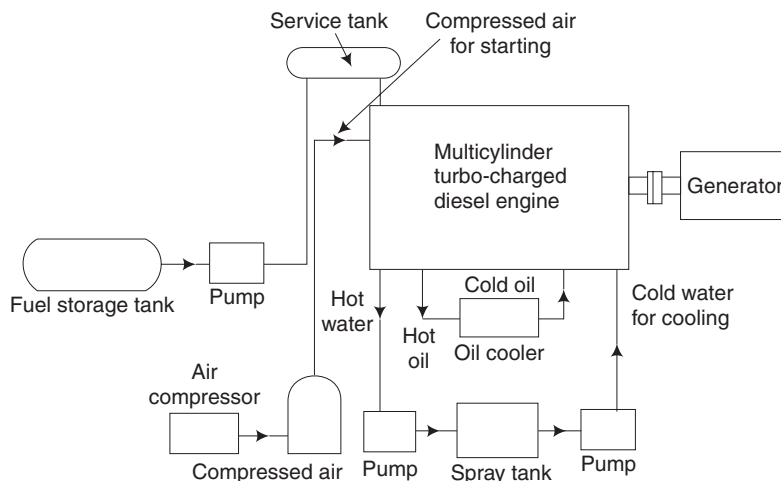
1. Flexibility as to the type of fuel.
2. Uncontaminated working medium, and hence maintenance is easier.
3. Possibility of using a gas having better thermal properties as the working medium. By using an inert gas with high specific heat, the unit will become compact.

## 8.6 DIESEL POWER PLANT

[May 2009, 2012; Nov 2014, Regulation 2008]

The layout of a diesel power plant is given in Fig. 8.6. Normally, multicylinder 2-stroke turbocharged diesel engines are used in power plants (for the principle of working of a diesel engine, please refer to chapter on IC Engine). In a turbocharged engine, the atmospheric air is compressed by a compressor run by an exhaust-driven gas turbine and

the compressed air is taken inside the cylinder. Due to this, mass of air intake and amount of fuel burnt will be considerably increased giving rise to increased output power and higher thermal efficiency.



**Fig. 8.6** Layout of diesel power plant

Due to turbocharging, the operating temperature of the engine is increased. So, the lubricating oil coming out of the engine should be cooled in an oil cooler. The cooling water from the engines is normally cooled in a spray tank and recirculated. Due to high capacity, the engine is started by using compressed air.

### 8.6.1 Advantages of Diesel Power Plant

1. Plant layout is simple.
2. Easy to install and commission the plant, in comparison with the steam power plant or hydro-plant.
3. Quick starting and easy pick-up of loads are possible in a very short time.
4. Power plant can be located near the load centre.
5. The load operation is easy and requires minimum technical staff.
6. Efficiency at part loads does not fall low.
7. Fuel handling is easier and no problem of ash disposal exists.

### 8.6.2 Disadvantages of Diesel Power Plant

1. Maximum capacity of the plant is limited to about 50 MW of power.
2. Diesel fuel is much more expensive than coal.
3. Cost of maintenance and lubrication is high.
4. Overload running may not be possible.

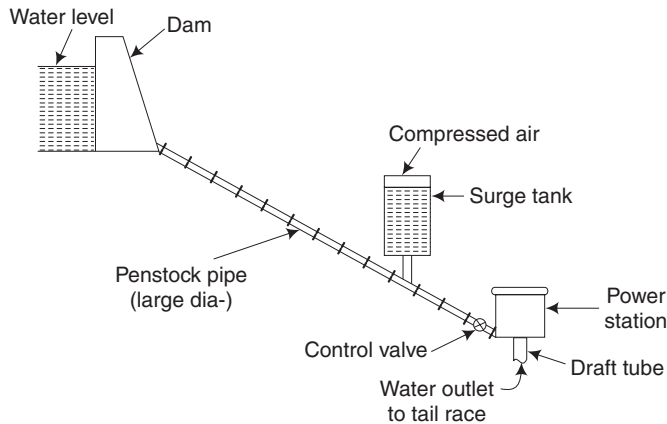
## 8.7 HYDROELECTRIC POWER PLANT

[Nov 2010; May 2012, Regulation 2008]

In a hydroelectric power plant, the potential energy of water stored in a dam is made use of in running a water turbine coupled to an electrical generator. It is estimated that about 23 per cent of the total electric power in the world comes from hydro power. In Tamil Nadu, the total generation of power from hydroelectric plants amounts to 1950 MW and in an all-India level, it amounts to about 18000 MW.

### 8.7.1 Layout of a Hydroelectric Power Plant

The layout of a hydroelectric power plant is given in Fig. 8.7. The water from the dam is brought to the water turbine by a large diameter penstock pipe. The penstock pipe is made of steel or reinforced concrete. It is desirable to eliminate sharp bends in the penstock pipe to avoid the loss of head and special anchoring.



**Fig. 8.7** *Hydroelectric power plant*

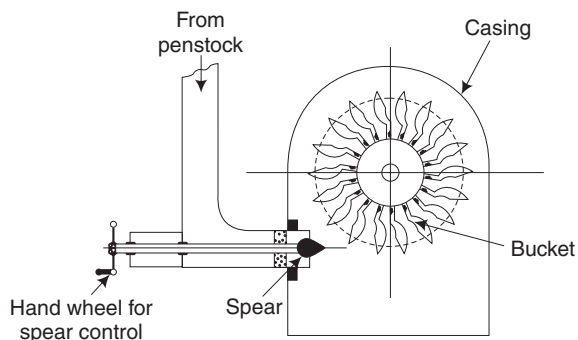
Depending upon the load on the turbine, the amount of water needed is controlled automatically by a valve operated by a centrifugal governor. In case the amount of water is suddenly reduced or stopped by the governor mechanism, water coming down with a high velocity will produce turbulence resulting in a water hammer in the pipe. The penstock pipe may be damaged due to the water hammer. To prevent this, a surge tank is provided. Surge tank is a large closed tank, which will get filled up with water in the event pressure raise in the penstock and the air inside the surge tank shall get compressed. This will safeguard the turbine plant, control valve and the penstock itself. When pressure becomes normal, the accumulated water will flow back to the penstock and to the turbine to produce power. From the turbine, water is allowed to pass through a draft tube to the tail race. The tail race is the water path leading the discharge water from the turbine to the river or canal.

## 8.7.2 Types of Water Turbines

Depending upon the head of water available, different types of water turbines are used as given below:

**1. Pelton Wheel** It is an impulse turbine used for high head. A pelton wheel is used at Pykara Power House where a head of more than 900 m is available. The turbine is named after Lester A Pelton (1829–1908), an American engineer, who developed it in about 1880.

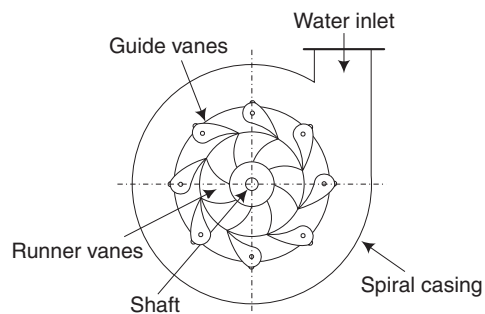
Figure 8.8(a) shows the Pelton wheel installation. The runner consists of a circular disc with large number of buckets or blades fixed on its periphery. The buckets have the shape of a double semi-ellipsoidal cup. These buckets are made by cast steel, bronze or stainless steel. Water can be controlled by rotating the hand wheel by moving the spear in the case of a small unit. In bigger units, it will be controlled automatically by a governor. The casing is made of cast iron or fabricated steel plates.



**Fig. 8.8(a)** Pelton wheel

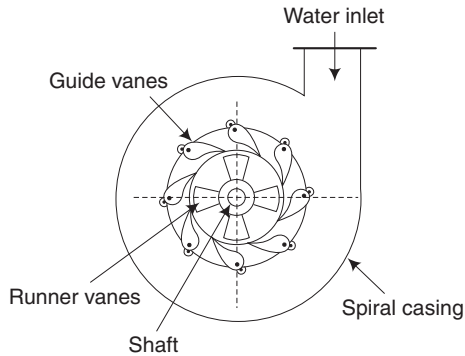
**2. Francis Turbine** It is a mixed-flow type reaction turbine. It is used for medium heads ranging from 50–400 m. Francis turbine is used at the Periyar Hydroelectric Project where a head of about 374 m is available. The main components are a spiral casing, guide blades and a runner as shown in Fig. 8.8(b). This turbine was developed by the American Engineer JB Francis in 1849.

Water from the penstock pipe enters the casing and flows radially towards the centre of the runner. The casing is usually made of steel. The water is guided to the runner by guide vanes. Guide vanes are made of steel or stainless steel. The runner consists of a series of curved vanes numbering 16 to 24. The vanes are so shaped that water enters the runner radially and leaves it axially. It is usually made of mild steel or stainless steel.

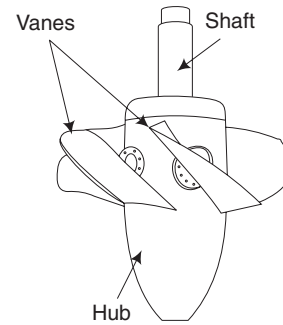


**Fig. 8.8(b)** Francis turbine

**3. Kaplan Turbine** Kaplan turbine is an axial flow reaction turbine. The German engineer V Kaplan developed this turbine in 1916. This is suitable for low heads ranging from 1.5 m. It is similar to the Francis turbine in construction, except for the runner. The runner has only 3, 4 or 6 blades. The four blades or vanes are shown in Fig. 8.8(c). The blades are adjustable only in a Kaplan turbine.



**Fig. 8.8(c)** Kaplan turbine



**Fig. 8.8(d)** Kaplan turbine runner

**Table 8.1(a)** Advantages and disadvantages of hydroelectric power plant

<i>Advantages</i>	<i>Disadvantages</i>
1. No fuel cost.	Initial cost for the construction of dam is high.
2. Operating cost is very minimum	As a load centre is normally away from the dam, the transmission lines are quite long.
3. Efficiency of hydro-plant is high	When the power house is at a long distance from the dam, construction of surge tank of a great height is essential to prevent water hammer in the penstock pipe.
4. There are auxiliary benefits like irrigation, etc.	
5. No atmospheric pollution.	

**Table 8.1(b)** Comparison of thermal and hydroelectric power plant

<i>Thermal power plant</i>	<i>Hydroelectric power plant</i>
1. Not affected by seasons.	Affected by seasons.
2. Can be installed at any place.	Only near a dam.
3. Operating cost is high.	Negligible as there is no fuel cost.
4. Transmission of power is comparatively easier.	Not so economical as transmission towers should be erected in hill area.
5. Capital cost is comparatively less.	Cost including dam is much higher.
6. Fuel may be exhausted in due course of time.	Water will not be exhausted.
7. There is a problem of pollution of environment.	Free from pollution.

## 8.8 ENVIRONMENTAL CONSTRAINTS OF POWER GENERATION

Raw energy is processed and transformed into usable energy forms by means of energy-conversion processes. These energy-conversion processes create pollution problems which disturb the ecological balance.

Power plants are used for transforming raw energy into electrical energy. The power generation in coal-fired power plants emits solid particles,  $\text{SO}_x$ ,  $\text{NO}_x$ ,  $\text{CO}$ ,  $\text{CO}_2$  and waste chemicals into the environment. Nuclear power plants, thermal power plants, chemical conversion plants, etc., also emit solid, liquid and gaseous pollutants in the environment. The gaseous pollutants cause global environmental problems like global warming and greenhouse effect. Some important environmental constraints of power generation are given below.

**(i) Particulate Matter** Solid or liquid particles present in the air are called particulate matter. Their size varies from 100 nm and 2.5  $\mu\text{m}$ . Dust and fly ash emitted from the power plants are the significant sources of particulate matter in air.

**(ii) Acid Rain, Acid Snow, Acid Fog and Dry Acidic Deposition** Increased concentrations of sulphur oxides ( $\text{SO}_x$ ) and nitrogen oxides ( $\text{NO}_x$ ) in the atmosphere cause these global environmental effects.

**(iii) Greenhouse Effect** A greenhouse has transparent glass panes, which allow sunlight to enter and prevent exit of heat,  $\text{CO}_2$  and moisture. The climate inside the greenhouse is warm due to high concentration of  $\text{CO}_2$  and moisture. A similar effect is created by higher concentration of  $\text{CO}_2$  in the atmosphere and is called the greenhouse effect.

**(iv) Global Warming** The warming up of earth due to the greenhouse effect is called global warming. In this process,  $\text{CO}_2$  in the air allows the entry of radiation heat of sunlight, which contains short waves and visible portion of the spectrum. This heat is then absorbed by the earth and the atmosphere.

## 8.9 ALTERNATE SOURCES OF ENERGY

Search and effective use of alternate sources become need of the day due to two reasons. Firstly, the non-availability of the fossil fuels in the near future and secondly, the environment awareness. The following sections discuss on the different alternate sources.

### 8.9.1 Solar Energy

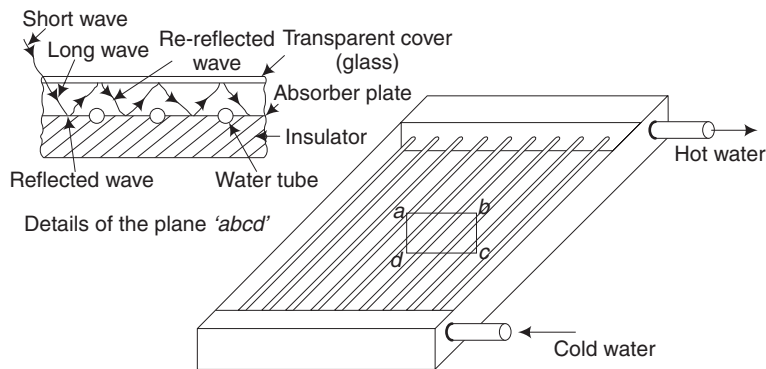
From the consumption pattern of various fossil fuels (natural gas, fuel oil, coal, etc.), it has been estimated that petroleum products and coal are not going to last beyond 50 and 100 years respectively. As a result, every country needs to develop technologies which make use of non-conventional sources of energy such as solar, wind, tidal and geothermal.

In spite of the enormous distance between the sun and earth, the radiation output by the sun is very powerful. The earth is shielded from harmful effects of radiation by the atmosphere which surrounds the earth and particularly by the ozone layer in the stratosphere. It has been estimated that the earth receives about  $10^{18}$  kWh of solar energy every year. The total worldwide annual energy requirement is about  $80 \times 10^{12}$  kWh. This shows that the world energy consumption can be met if a small percentage of sunlight incident on the earth is effectively utilised.

### 8.9.1.1 Solar Heaters

By using solar radiation, water or any fluid can be heated by using a flat plate collector or a parabolic reflector. Solar water-heating systems have many applications in the domestic and industrial sectors. Such systems can provide hot water for different applications in industries directly or as boiler feed and also in hostels, hotels and canteens.

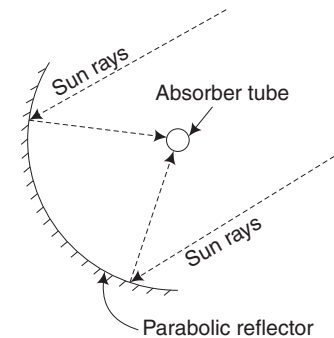
**Solar Flat-Plate Collector** The arrangement of a solar flat-plate collector is shown in Fig. 8.9. The absorber plate normally is metallic. It is usually coated black to absorb more thermal energy. Tubes, passages or channels integral with the collector carry water, air or other working fluids. Insulation should be provided at the back and at the sides to minimise the heat losses. Usually, glass wool is used as insulating material.



**Fig. 8.9** Solar flat-plate collector

A transparent cover (usually glass) should be provided on the top. This cover will permit the radiation from the sun on to the metal plate since it is at a shorter wavelength. When the radiation strikes the plate, a part of the energy is reflected back to the cover. As the radiation is at a higher wavelength, it will not go out to the atmosphere. Instead, the cover will reflect the energy back to the absorber plate and thereby increase the heat transfer. If there is no transparent cover, the reflected energy would have been lost. If the circulating fluid is water, the hot water can be collected in a tank and recirculated. A small water-circulating pump can also be introduced at the inlet side of the collector. Such a system gives a better result due to improved heat transfer.

**Parabolic Reflector** The parabolic reflector is shown in Fig. 8.10. Highly polished metallic surfaces are used as reflectors. The reflector will normally have a parabolic shape so that the sun rays striking the profile will be reflected on its focal point. If a tube carrying a fluid is kept along the focal line, the fluid will be heated to a very high temperature.



**Fig. 8.10** Parabolic concentrator



### 8.9.1.2 Solar-Power Generation

The World Energy Council predicts a 75% per cent growth in demand for energy by 2020. Most of the electricity is generated from coal, leading to the emission of greenhouse gases such as  $\text{CO}_2$  which contribute to global warming. The world is trying to reduce greenhouse gas emissions after the Kyoto Summit on Climate Change in 1997 and the ministerial meeting in Buenos Aires in 1998. Today, the use of solar energy for power generation is getting intense attention, because it is eco-friendly. At present, the cost of converting solar power into electricity may be high, but it is expected to come down in future.

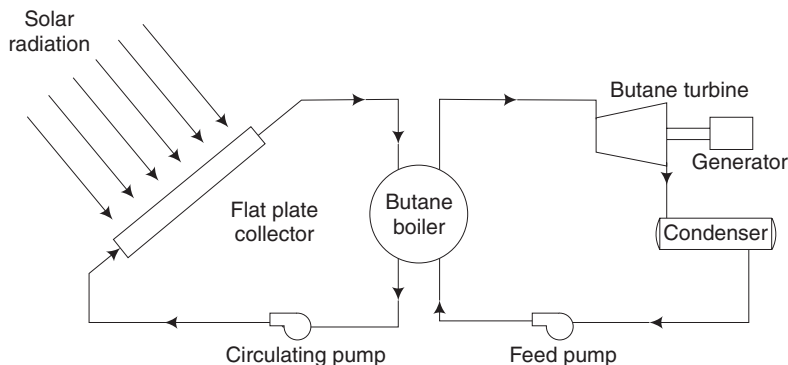
Recently, a British company has developed a system which uses fixed concave mirrors to trap and concentrate the solar energy which heats the air to about  $1000^\circ\text{C}$ . This hot air in turn drives a gas turbine generating electricity. One such system built on the Mediterranean island of Crete employs  $800\text{ m}^2$  of mirrors fixed at ground level producing 35 kW of power. This system can be installed in remote villages, hospitals and hotels. It can also be used to desalinate water for air-conditioning and cooking.

The direct conversion of solar energy into electricity is made possible by using the photovoltaic effect in certain materials. The basic unit of photovoltaic system is the solar cell. The first practical solar cell was produced in 1954 by Bell Telephone Laboratories in USA. This cell was made from a single crystal silicon. A solar cell is a semiconductor device processed and fabricated in a manner which permits the generation of voltage when light falls on it. The voltage is capable of driving an electric current through an external circuit.

The power from the solar cells can be used for the operation of a calculator, pump set, radio station, TV station, satellite, etc. The power obtained in the day time can be stored in solar batteries. At present, the cost per unit power is quiet high which can be expected to come down in the future.

### 8.9.1.3 Solar Power Plant using Butane Boiler

Water in the flat-plate collector is heated from  $70$  to  $80^\circ\text{C}$  due to solar radiation. The hot water heats the butane liquid in the butane boiler. As butane vaporizes at  $50^\circ\text{C}$ , water at  $70$  to  $80^\circ\text{C}$  is able to vaporize butane. Hot water after transferring the heat to butane is pumped by a circulating pump to the flat-plate collector where it is again heated.



**Fig. 8.11** Solar power plant using butane boiler

Butane vapour from the boiler is taken to the butane turbine which is connected to an electric generator. Exhaust vapour from the turbine is condensed in a condenser and the liquid butane is pumped by a feed pump to the butane boiler. The cycle will be repeated.

### **Advantages of Solar Power Plant**

1. Heat energy from the sun is freely available so there is no pollution problem.
2. No transport and storage problem of any fuel.
3. Easy to construct and erect.

### **Disadvantages**

1. Solar energy is not available during night.
2. Power produced is rather small.

## **8.9.2 Wind Energy**

A total of  $10^{11}$  gigawatts of wind power is available around the earth surface. Hence, a successful harnessing of even a small fraction of this substantial energy source can bridge the gap between the energy demand and supply. The potential of wind energy in India is 20000 MW. Large areas having annual average wind speeds of above 20 kmph are available in Tamil Nadu, Andhra Pradesh, Kerala, Karnataka and coastal areas of Gujarat and Maharashtra. At present, about 970 MW of electric power from wind energy is produced in India.

Tamil Nadu stands first in the generation of wind electric power in our country. The total wind electric-power generation in Tamil Nadu in 1995 was about 300 MW which was expected to touch the 1000 MW mark by the beginning of the 21st century. With the assistance of the Ministry of Nonconventional Energy Sources (MNES), the Tamil Nadu Energy Development Agency (TEDA) has erected several windmills in Kayathar, Kethanpur, Muppandal, Puliankulam, Sultanpet and Tuticorin. Muppandal in the Kanyakumari district has the highest average wind speed in Tamil Nadu.

### **8.9.2.1 Theory of Wind Power**

The power available in the wind can be expressed by the following formula.

$$P = \frac{\pi}{8} \rho d^2 V^3$$

where  $P$  = power, W  
 $\rho$  = density of air,  $\text{kg/m}^3$   
 $d$  = diameter of blades in metres  
 $V$  = Wind velocity, m/s

The major problem with wind power is that large windmills are required for generating power especially in low wind-velocity regions. The unsteady nature of wind w.r.t. direction and velocity is an additional problem. For economic viability of wind electric generation, wind velocity should be in the range of 7 m/s to 10 m/s. However, winds at lower velocities can operate positive displacement pumps to lift water from wells for domestic use and minor irrigation.

### 8.9.2.2 Types of Windmills

The following types of windmills are available.

1. High-speed two-blade windmill
2. Medium-speed three-blade windmill
3. Savonius rotor windmill
4. Darrieus rotor windmill
5. Propeller windmill

A location having the following features can be considered desirable for windmills.

1. The site should have a high annual wind speed.
2. There should be no tall obstructions in the neighbouring area such as
  - Top of a hill with gentle slopes
  - An open shore line
  - A mountain gap which produces wind funnelling

### 8.9.2.3 Utilisation of Wind Energy

A windmill for generating electricity is shown in Fig. 8.12(a). It consists of a tower-mounted, two-bladed or multi-bladed rotor facing the wind, rotating around a horizontal axis and turning an electrical generator. The power in the wind increases with the cube of the wind speed. Such windmills are manufactured with a capacity from a few kW to several MW in Europe, US and other parts of the world including India. They are either linked to a grid or function in an autonomous mode. For a capacity of 100 kW, the diameter is in the range of 20 m and for 250 kW, the diameter is about 32 m. The total cost of a windmill set-up having a capacity of 250 kW is in the range of Rs 1 crore.

Figure 8.12(b) shows the side view of a horizontal axis, multi-bladed windmill for pumping water from wells for domestic use or for minor irrigation. The head against

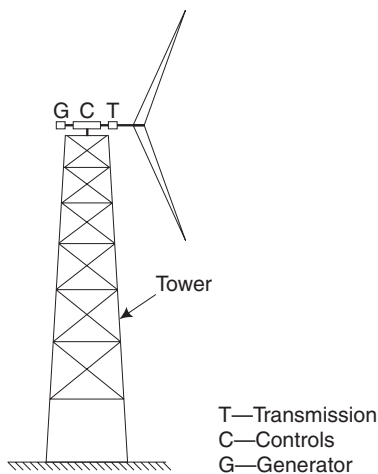


Fig. 8.12(a) Windmill for generating electricity

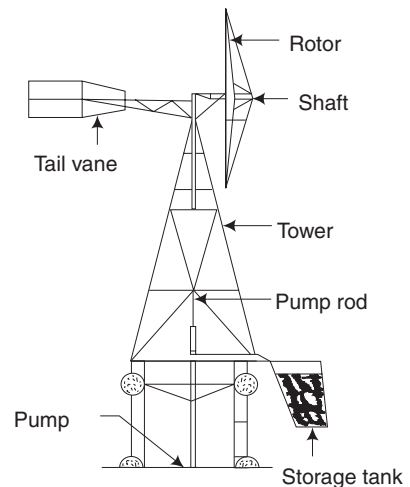
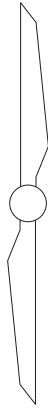
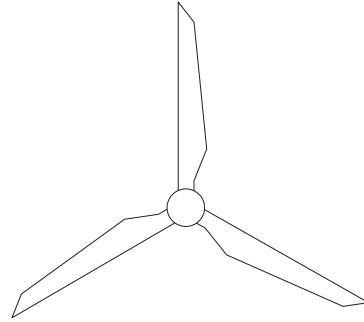


Fig. 8.12(b) Horizontal-axis multi-blade water-pumping wind mill



**Fig. 8.12(c)** *Two-blade rotor*



**Fig. 8.12(d)** *Three-blade rotor*

which water is pumped ranges from 3 m to 15 m with a seasonal variation of the order of 5 m. Considering the low speed of windmills, it is most convenient to couple it with positive displacement pumps which can operate efficiently at these speeds. The rotor speed has to be stepped up when it is connected with rotor dynamic pumps. The excess water pumped can be stored in overhead tanks and can be used in nonwindy periods. The tailvane helps the blades to change in the direction of wind. Anemometer can indicate the velocity of wind.

A modern application of windmill water-pumping operation involves pumping water under high pressure to irrigation sprinklers. In another option, the water-pumping windmill drives a small air compressor and the compressed air pumps the water. An advantage of this system is that the windmill can be located at a convenient site away from the well.

### 8.9.3 Tidal Power

The rise and fall of tides in an estuary (river mouth into which the tide flows from the sea) can be made use of to drive specially designed low-head water turbines. These turbines can operate even at very low heads as 0.5 m. Several tidal power plants already exist in many parts of the world. At the mouth of the Rance river in France, a tidal plant with a capacity of 240 MW is producing electricity for commercial use since 1966.

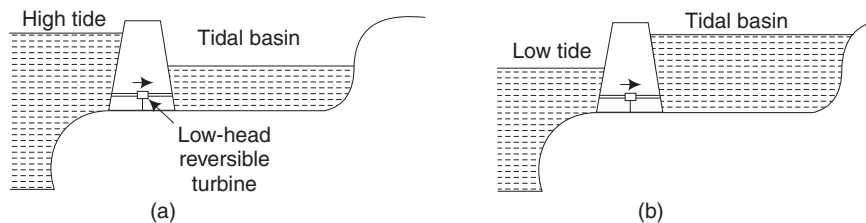
India's first tidal power plant, the Kachchh Tidal Power Project, the biggest project of its kind in the world, is to be built at Navlakhi near Kandla port in Gujarat. The expected power to be generated in this project is about 850 MW from 34 generating sets of 25 MW each. As per the estimate in 1991, the cost of the project is about Rs 1150 crore.

A tidal power plant mainly consists of the following:

1. A barrage with gates and sluices
2. One or more basins
3. A powerhouse

A *barrage* is a barrier constructed across the tidal reach to create a basin for storing water. The barrage has to withstand the pressure exerted by the water head and should also resist the shock of the waves. So the side slope of the barrage should not be steep.

A *basin* is the area where water is retained by the barrage. A tidal power scheme can have a single basin or multiple basins. Low-head reversible water turbines are installed in the barrage separating the sea from the basin. The electric generator and a number of turbine components are enclosed in a water-tight bulb, with the whole hydroelectric unit submerged in water. The simple arrangement of a tidal power plant is given in Figs 8.13(a) and 8.13(b) which also indicate the level of water during high tides and low tides.



**Fig. 8.13(a) and (b)**

#### **Advantages of a Tidal Power Plant**

1. It is an inexhaustive source of energy.
2. There is no problem of pollution.
3. After the capital cost, the cost of power generation is quite low.

#### **Disadvantages of a Tidal Power Plant**

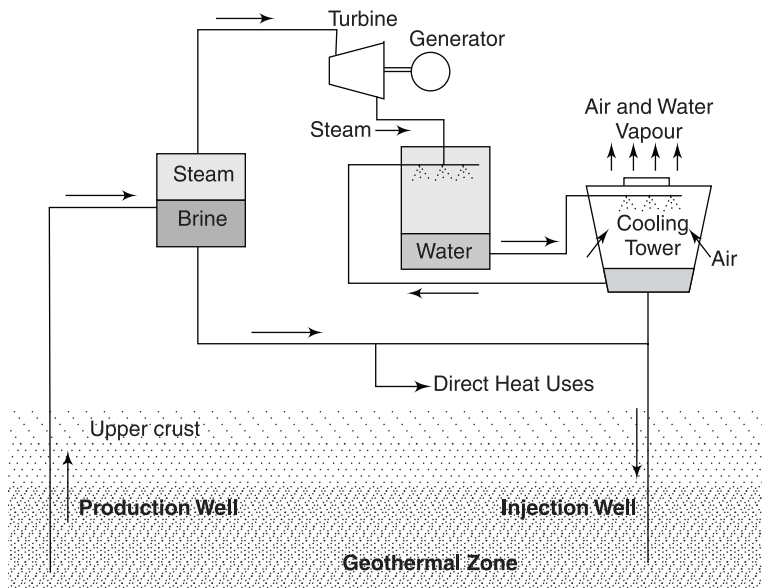
1. Capital cost is very high compared to a thermal or a hydroelectric power plant.
2. As the head is not constant, variable output is obtained.
3. As the head is only low, a large amount of water is necessary for the turbine.
4. The operation of the turbine will have to be stopped when the available head is less than 0.5 m.

#### **8.9.4 Geothermal Power**

Geothermal power plants derive energy from the heat of the earth's interior. The average increase in temperature with depth under the earth is  $1^{\circ}\text{C}$  for every 30–40 m. At a depth of 10–15 km, the earth's interior is as hot as  $1000\text{--}1200^{\circ}\text{C}$ . In certain areas of our planet, the underground heat has raised the temperature of water to over  $200^{\circ}\text{C}$  which bursts out as hot steam through the cracks in the earth's crust. These are called *thermal springs*. This steam can be used for the generation of electric power. Boreholes are normally sunk with a depth up to 1000 m releasing steam and water at temperatures ranging from  $200\text{--}300^{\circ}\text{C}$  and pressure up to 30 bar. Steam is transmitted by pipelines to the power station. Due to low steam pressure, the station efficiency is only 10 to 15 per cent.

In New Zealand, geothermal power plants account for 40 per cent of the total electric output, and in Italy for 6 per cent. Several installations for output, up to about 20 MW are in use in various parts of the world, but the chief installations are the 500 MW station near Lardarele, Italy, and the 250 MW station at Wairaki, New Zealand.

Even in India, hot springs are available. Manikaran in Himachal Pradesh and Puger Valley in Jammu and Kashmir have good potential for generation of energy. These areas have been surveyed and recommended for the installation of geothermal power plants with a capacity of 25 MW.

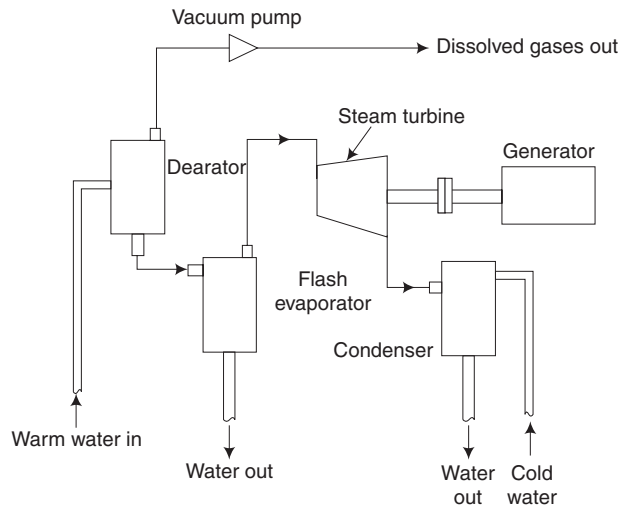


**Fig. 8.14** Schematic diagram of a geothermal power plant

### 8.9.5 Ocean Thermal Energy Conversion (OTEC)

The heat contained in the ocean could be converted into electricity by utilising the temperature difference of 20–25 K between the warm water on the surface and the cold water at a depth of about 600 m. The high temperature of surface water could be used to heat some low-boiling organic fluid, the vapour of which could run a heat engine. The exit vapour would be condensed by pumping cold water from the deeper regions. The amount of energy available for ocean thermal power generation is enormous.

The first OTEC plant was built by the Frenchman Georges Claude in 1929 at the Mantanzas Bay in Cuba. The warm surface water was at 25°C. The cold water at 11°C was tapped by a long pipe. As the Claude plant used an open cycle in early times, the open cycle system is sometimes referred to as 'Claude cycle'. In the open cycle, the condensate need not return to the evaporator. A schematic diagram of the open cycle OTEC system is shown in Fig. 8.15.



**Fig. 8.15** Schematic diagram of an open-cycle OTEC system

#### 8.9.5.1 Open-Cycle OTEC System

The open cycle uses sea water as the working fluid. The warm water is first sent to the deaerator where the dissolved gases are removed by means of a vacuum pump. Then, the warm water is flash evaporated under a partial vacuum in the flash evaporator. This process produces low pressure water vapour / steam, which will be the working fluid in the OTEC system. The low pressure steam is then passed through a turbine which extracts energy from it and runs a generator. The vapour, after expansion in the turbine, is then cooled in the spray condenser (direct contact) is used where the condensate is mixed with the cooling water, and the mixture is discharged into the ocean.

It is to be noted here that since we have to obtain energy from low-pressure steam, extremely large-sized turbines must be used.

The cost of an open-cycle system for producing electric power is significantly greater than that of a closed-cycle system. The turbine cost alone amounts to almost half the cost of the entire power system.

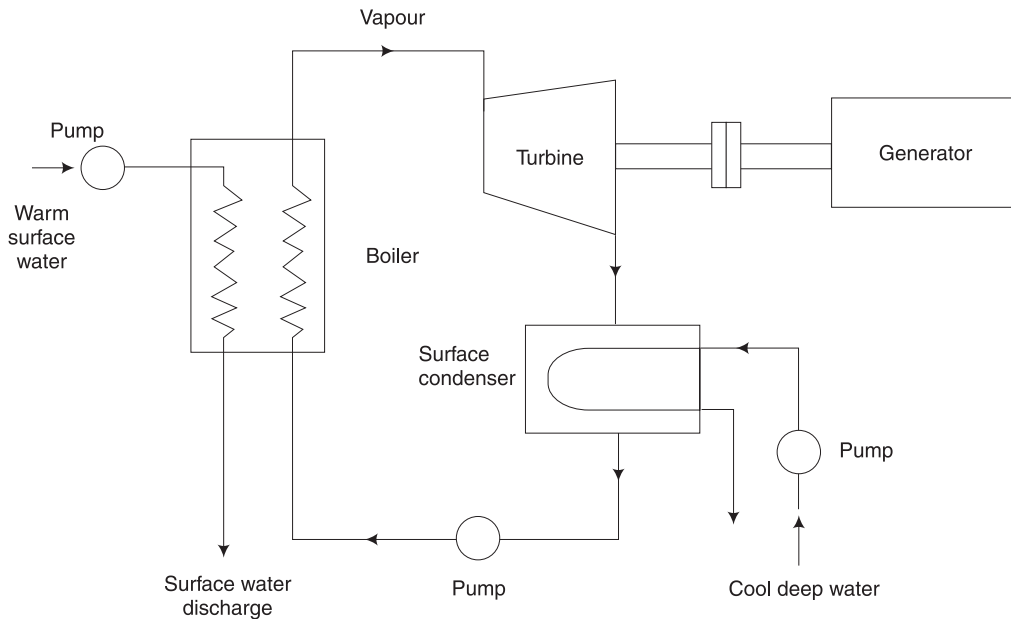
#### 8.9.5.2 Closed Cycle OTEC System

The first published work on OTEC by d' Arsonvol in 1881 actually suggested a closed cycle and that article proposed sulphur dioxide as the working fluid. Later, in the closed cycle, working fluids such as ammonia, propane or freon with higher vapour pressures at the temperatures available were used.

The most recent design on the closed-cycle OTEC system was done by Anderson and Anderson in the 1960s. Hence, the closed cycle is sometimes referred to as '*Anderson cycle*'. They used propane as the working fluid, with a 20°C temperature difference between the warm surface and cold water. The cold water was taken from a depth of about 600 m.

Roughly, 14 per cent of the gross power was expected to be consumed internally. The size of the plant was gigantic. A schematic diagram of the closed cycle OTEC power plant is shown in Fig. 8.16.

In boilers and condensers, extensive areas are needed to transfer significant amounts of heat due to low temperature differences. In other words, large volumes of water must be circulated through the OTEC power plant, requiring large heat exchangers.



**Fig. 8.16** Schematic diagram of a closed-cycle OTEC power plant

The warm water from the surface of the sea is pumped into the boiler where it loses its heat to the propane and is discharged out. The propane gets vaporized and is expanded in the turbine coupled to a generator producing the electrical power. The vapour after expansion is condensed in the surface condenser by means of cool deep-sea water. The condensed propane is again sent to the boiler by means of a pump.

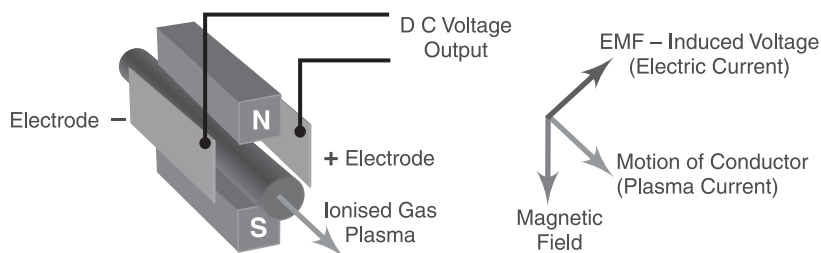
**Recent development of OTEC systems** In the international scenario, large number of countries have recently been active in OTEC research and development. These include Japan, Sweden, Germany and Netherlands.

### 8.9.6 Magneto Hydro Dynamic (MHD) Power Generator

A magnetohydrodynamic (MHD) generator is a magnetohydrodynamic device that transforms thermal energy and kinetic energy into electricity. MHD generators are different from traditional electric generators in that they operate at high temperatures without moving parts.



MHD generator system is a non-conventional source of energy which is based upon Faraday's law of Electromagnetic Induction. It consists of a wedge-shaped pipe or tube of some non-conductive material. MHD generator, like a conventional generator, relies on moving a conductor through a magnetic field to generate electric current. The MHD generator uses hot conductive plasma (gas in the range of 2000 to 3000°C), as the moving conductor. It may be noted that when the gas temperature is reduced to less than 2000°C, the conductivity of the gas is totally lost. So, the MHD generator can't function. When an electrically conductive fluid flows through the tube, in the presence of a significant perpendicular magnetic field, a charge is induced in the field, which can be drawn off as electrical power by placing the electrodes on the sides at 90 degree angles to the magnetic field. The amount of power that can be extracted is proportional to the cross sectional area of the tube and the speed of the conductive flow.



**Fig. 8.17** Principle Magnetohydrodynamic (MHD) Power Generation

MHD generators use coal or natural gas. MHD acts like a topping cycle, a combined cycle, to increase the efficiency of electric generation. Hot exhaust gas of an MHD generator can heat the boiler of a steam power plant or gas turbine plant, increasing the overall efficiency.

### Short-Answer Questions

1. Answer the following questions:

- List out the conventional power plants.
- What are the main purposes of a condenser in a steam power plant?
- Write three factors to be considered for the selection of a steam-power-plant site?
- State two advantages and disadvantages of a nuclear power plant.
- Briefly write the working principle of a gas turbine.
- List the main components of an open-cycle gas turbine.
- Give two advantages and disadvantages of a gas turbine.
- State the methods of improving the thermal efficiency of a gas-turbine cycle.
- Give two examples for reaction hydraulic turbine.

- (j) What is the use of a surge tank in a hydraulic power plant?
  - (k) What are the alternate sources of energy to fossil fuel?
  - (l) What is a 'solar cell'?
  - (m) Describe a solar heater with an example.
  - (n) Give two locations of windmill power plants in Tamil Nadu.
  - (o) What are the main components used in a tidal power plant?
  - (p) Explain greenhouse effect.
  - (q) What is global warming?
2. Fill up the blanks with suitable word/words:
- (a) A nuclear power plant is similar to a steam power plant, except that \_\_\_\_\_ is replaced by \_\_\_\_\_.
  - (b) Thermal shielding reduces \_\_\_\_\_ and the concrete shielding prevents \_\_\_\_\_ in a nuclear power plant.
  - (c) In a diesel power plant, turbocharging is used to increase \_\_\_\_\_.
  - (d) \_\_\_\_\_ turbine is used in a hydroelectric power plant.
  - (e) The Pelton wheel is an example of \_\_\_\_\_ turbine.
  - (f) A windmill converts \_\_\_\_\_ energy of \_\_\_\_\_ to electricity.
3. Choose the correct answer from the following:
- (a) Heat energy released by 1 kg of uranium is equivalent to
    - (i) 3000 tons of coal
    - (ii) 4500 tons of coal
    - (iii) 450 tons of coal
    - (iv) 1 kg of coal
  - (b) In an open-cycle gas turbine, the fuel is injected in the
    - (i) compressor
    - (ii) turbine
    - (iii) combustion chamber
    - (iv) condenser
  - (c) An axial-flow hydraulic turbine is the
    - (i) Francis turbine
    - (ii) Kaplan turbine
    - (iii) Pelton wheel
  - (d) A solar cell works on
    - (i) photovoltaic effect
    - (ii) Thomson effect
    - (iii) Zeebeck effect
    - (iv) solar effect
4. State whether the following statements are true or false:
- (a) A deaerator is used to remove air and oxygen from the condensate in a steam power plant.
  - (b) Thermal efficiency of a simple gas turbine is very low.
  - (c) In a hydroelectric power plant, a centrifugal governor is used to control the amount of water, depending upon the load on the turbine.

- (d) A solar cell converts electrical energy into solar energy.
  - (e) The fluid will be heated to a very high temperature in a parabolic reflector compared with flat-plate collector.
5. *Distinguish between the following:*
- (a) Conventional steam power plant and nuclear power plant
  - (b) Open-cycle and closed-cycle gas turbine
  - (c) Impulse and reaction hydraulic turbine
  - (d) Thermal and hydroelectric power plant

### *Exercises*

1. Differentiate between two stroke and four stroke engine.
2. Write in detail about the working principle of two stroke cycle Engine.
3. Discuss the working of four stroke cycle petrol engine with the help of neat sketch.
4. Explain the forced – circulation water cooling system in I.C. engine.
5. Write briefly about the fuel supply systems used in SI engines
6. Draw the layout of a Diesel Power Plant and explain its working.
7. Explain the working of a two stroke petrol engine, with sketches for the following events:
  - i. End of compression
  - ii. Beginning of exhaust
  - iii. Beginning of 'transfer of charge' into the cylinder
  - iv. Start of compression
8. What is the difference between internal combustion engines and external combustion engines? Give an example for each type.
9. Explain with neat sketch of steam power plant.
10. Briefly discuss – Boiler as a part of a steam power point.
11. Explain with a neat sketch of Nuclear power plants.
12. Draw and name the parts of Centrifugal Pump and explain its working.
13. Draw a sketch of a single acting reciprocating pump and briefly explain their functions.
14. Write briefly the principle of working of double acting reciprocating pump.
15. What is difference between single acting and double acting reciprocating pumps?



# Chapter 9

## STEAM BOILERS AND STEAM TURBINES

### 9.1 INTRODUCTION

[May 2014, Regulation 2008]

The function of a boiler is to evaporate water into steam at a pressure higher than the atmospheric pressure. Prime function of the boiler is to heat and evaporate the water and superheat the steam [May 2015, Regulation 2008; Apr 2015; Nov '2014, Regulation 2013]

Water free from impurities such as dissolved salts, gases and nonsoluble solids should be supplied to boilers. This is done by suitable water treatment. Steam is useful for running steam turbines in electrical power stations, ships and steam engines in railway locomotives. It is also useful for many industrial applications. Boiler furnace can use either solid, liquid or gaseous fuel. Boilers are mainly classified as fire-tube boilers and water-tube boilers. In the fire-tube boilers, hot gases from the furnace pass through the tubes which are surrounded by water. In the water-tube boilers, the water circulates inside the tubes which are heated from outside by the hot gases from the furnace. [May 2009, Regulation 2008]

A steam turbine is a prime mover in which rotary motion is obtained by the gradual change of momentum of the steam. Steam turbines are primarily used to run alternators or generators in thermal power plants. It is also used to rotate the propeller of ships through reduction gearing. The design and manufacture of turbine blades are quite complicated due to which there are only a limited number of manufacturers of steam turbines.

### 9.2 FORMATION OF STEAM

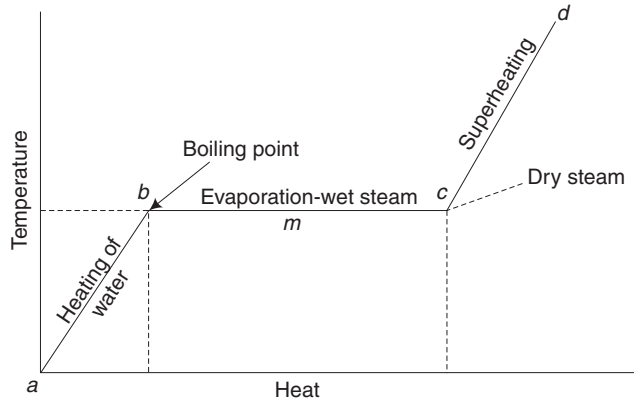
[May 2014, Regulation 2008]

Let us take 1 kg of water and heat at standard atmospheric pressure. Please refer to Fig. 9.1.

The temperature of water is raised till the boiling point.

**Boiling point of water** At standard atmospheric pressure, the temperature is 100°C. It increases with pressure. The value can be obtained from steam tables. At 10 bar, the boiling point is 179.9°C.

**Evaporation of water** The temperature remains constant. There will be mixture of water and steam till the point C. At the mid point  $m$ , only 0.5 kg of water would have been evaporated. Here, the dryness fraction of steam is 0.5.



**Fig. 9.1** Formation of steam

All the water is evaporated and the steam is said to be dry at the point C. The dryness fraction becomes 1.

**Superheating** The temperature is raised. In steam power plants, only superheated steam is used to run the turbines. Wet steam can be used for many industrial applications.

### 9.2.1 Types of Boilers

[May 2014, Regulation 2008]

Boilers may be classified in following ways:

**1. Fire Tube and Water Tube** In the fire boilers, the hot gases are inside the tubes and the water surrounds the tubes. Examples: Cochran, Lancashire and Locomotive boilers.

In the water tube boilers, the water is inside the tubes and hot gases surround them. Examples: Babcock and Wilcox, Stirling, Yarrow boiler, etc.

**2. Higher Pressure and Low Pressure Boilers** The boiler which produce steam at pressures of 80 bar and above are called high pressure boilers. Examples: Velox, Lamont, Benson Boiler etc.

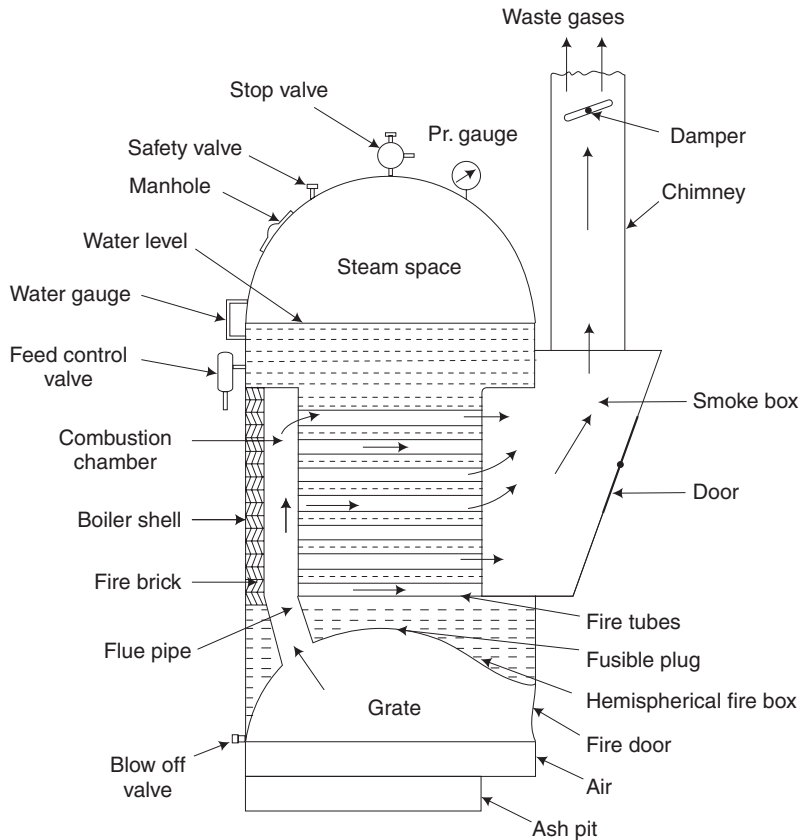
The boilers which produce steam at pressure below 80 bar are called low pressure boilers. Examples: Cochran, Babcock and Wilcox, Lancashire, Locomotive boiler, etc.

Boilers can be classified in many other ways as (i) Horizontal, Vertical or Inclined boilers, (ii) Externally Fired and Internally Fired boilers, (iii) Natural Circulation and Forced circulation boilers, (iv) Stationary and Portable boilers, (v) Single Tube and Multi Tube Boilers.

## 9.3 COCHRAN BOILER

This is a vertical fire-tube boiler as given in Fig. 9.2. The fuel is fed into the grate through the fuel door and lighted. The fuel is burnt in the grate and hot gases go to the combustion chamber through a short flue tube. The combustion continues in the combustion chamber.

The fire brick layer prevents the over-heating of the boiler shell. The hot gases pass through a large number of fire tubes and heat the surrounding water and convert it into steam. Since the steam is lighter, it goes up to the steam space. The fire tubes normally have 62.5 mm external diameter and are 165 in number. The crown of the boiler shell and grate are both hemispherical in shape. This boiler can evaporate upto 3800 kg of steam per hour, when the diameter is 3 m and the height is 6 m.



**Fig. 9.2** Cochran boiler

The waste gases enter the smoke box and are released through the chimney. The amount of waste gases leaving the chimney is controlled by means of a damper manually. When the damper is partly closed, amount of waste gases leaving the chimney will be reduced. Due to this action of the damper, the amount of air entering the grate will also be reduced and, obviously, only limited fuel can be burnt and the amount of steam generated also will be reduced. Thus, we find that the damper controls the rate of steam generated. Through the manhole, the boiler attender can enter inside the boiler shell for cleaning. By opening the door in the smoke box, the fire tubes and the smoke box can be cleaned by a wire brush.

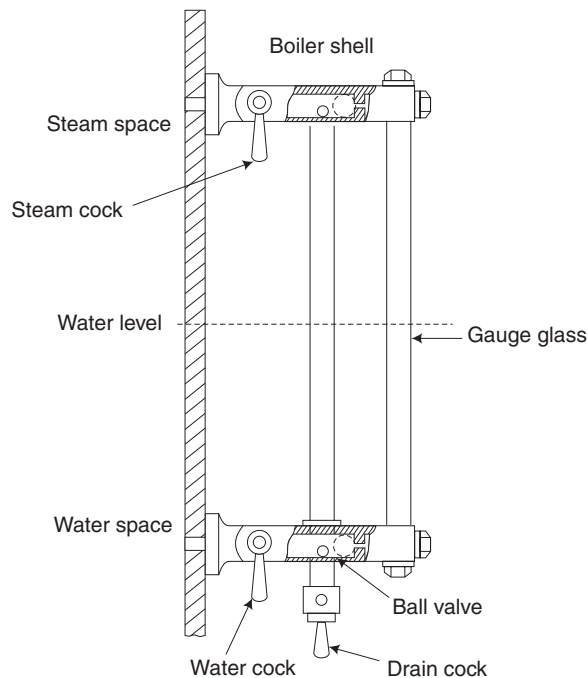
The diameter of the boilers varies from 1–3 m. The height of the boiler varies from 2–6 m. The evaporative capacity of the boiler ranges from 20–3000 kg/h. The boiler is fitted with various mountings as detailed in the following section.

## 9.4 BOILER MOUNTINGS

### 9.4.1 Water Gauge

This indicates the level of water inside the boiler. For small-capacity boilers, this is made with a thick glass tube with necessary protection and safety devices. By automatic control using float mechanism, the water level will be kept constant, with the help of a feed pump or a water injector. According to boiler regulations, two water gauges should be fitted in each boiler.

In case, the gauge glass breaks, the rush of water and steam will carry the *ball valves* to the position shown by dotted lines and prevent water or steam coming out of the boiler shell, as shown in Fig. 9.3(a).



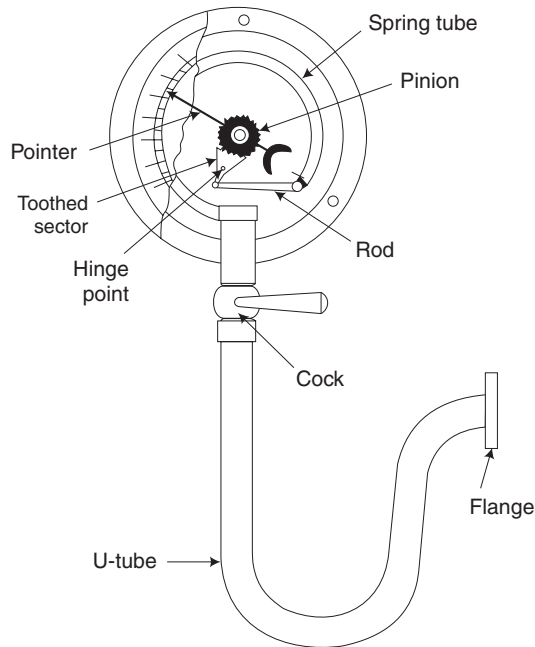
**Fig. 9.3 (a)** Water-level indicator

### 9.4.2 Pressure Gauge

This is to indicate the pressure of steam inside the boiler. At atmospheric pressure, the gauge will read zero. Periodically, the pressure gauge should be tested with a standard gauge and calibrated if necessary.



Refer to Fig. 9.3(b). The flange will be fixed on the boiler shell or drum and connected to the steam pressure. Depending upon the pressure, the *spring tube will deflect*. This deflection will be *magnified* to the pointer through the link mechanism consisting of rod, toothed sector and pinion. The U-tube will be filled with water.



**Fig. 9.3 (b)** Pressure gauge

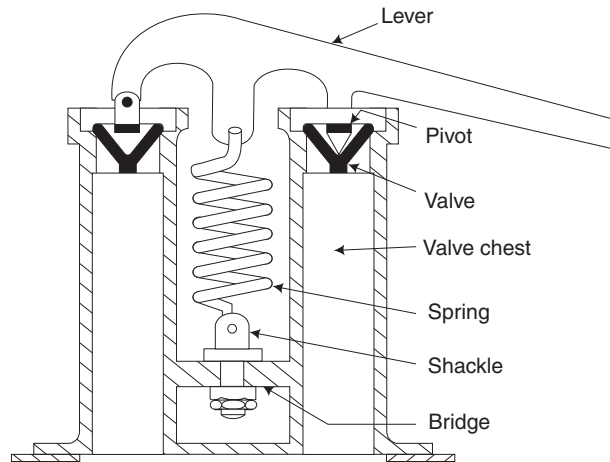
### 9.4.3 Safety Valve

This valve is *designed to open and let some steam out when the pressure exceeds the safe designed value*. In each boiler, there should be a *minimum of two safety valves*, as per the boiler regulations.

There are two types of safety valves. One is called *lever safety valve*. The other type is the *spring safety valve*, as shown in Fig. 9.3(c). In this valve, both the valves are kept closed by the spring. Pressure of the steam will be acting on the valve through the valve chest. If the pressure exceeds the designed value, the spring will be pushed up due to which the valves open, letting the steam out.

### 9.4.4 Main Steam Valve

This is to regulate or stop the flow of steam going out of the boiler to the turbine, engine, or process work.



**Fig. 9.3 (c)** Ramsbottom safety valve

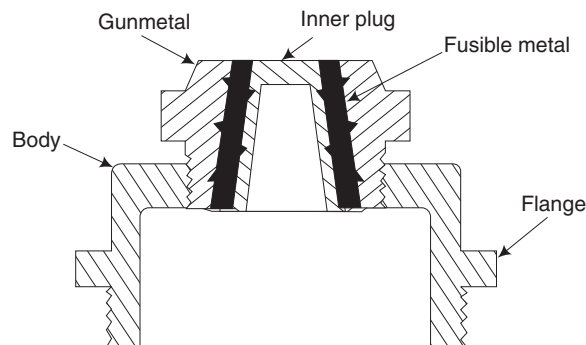
#### 9.4.5 Blow-off Valve

This valve is fitted at the lowest level of water. This helps to remove the salt deposits and other impurities accumulated in the bottom portion of the boiler shell or drum. This valve should be periodically opened keeping the steam under low pressure of about 2 bar.

#### 9.4.6 Fusible Plug

[May 2012, Regulation 2008]

This is one of the safety devices in many boilers. This prevents overheating of the fire box and other parts of the boiler, in case the water level becomes too low due to the failure of the automatic control. The plug will melt and create an opening through which water and steam will be allowed to put out the fire in the grate. The plug is made of a special alloy which has a comparatively low melting point. The fusible plug is shown in Fig. 9.3(d).



**Fig. 9.3 (d)** Fusible plug

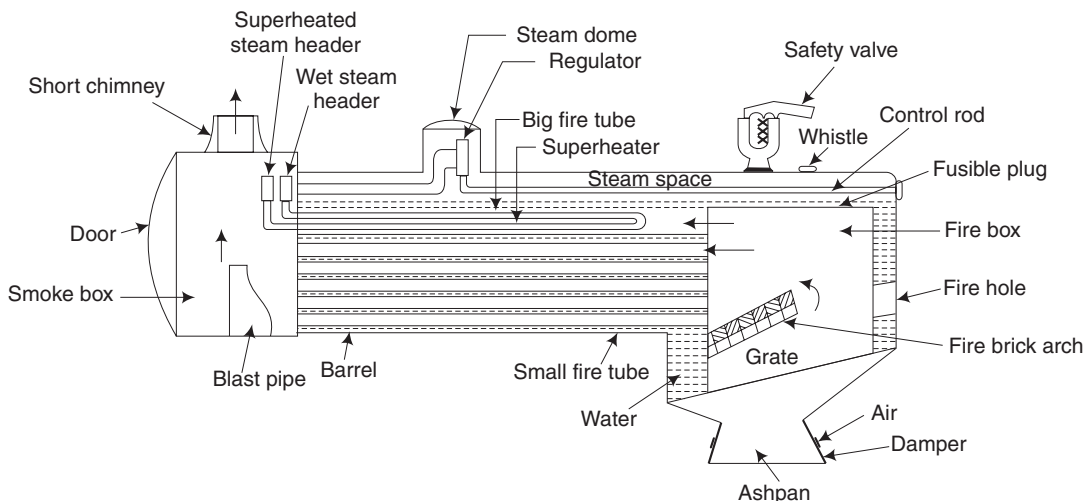
## 9.5 LOCOMOTIVE BOILER

It is a horizontal fire-tube boiler. It is mostly used for railways. It consists of a shell or barrel having 1.5-m diameter and 4-m length. Fuel is fed into the fire box through the fuel door. Air enters through the damper and the slots in the grate plate. The rate of combustion and the amount of steam generated is controlled by the dampers. The fire brick arch deflects the hot gases and improves the combustion efficiency.

The hot gases pass through large number of fire tubes and enter the smoke box. The circulation of air and hot gases is improved by means of induced draft produced in the smoke box. Waste steam from the engine enters the smoke box through the blast pipe and expands. Due to the expansion, it produces a partial vacuum which improves the movement of hot gases and air. Waste gases go out through a short chimney. A door is provided in the smoke box for inspection and cleaning.

To remove the moisture from the wet steam and to increase the temperature of steam, it is superheated as shown as Fig. 9.4. The wet steam through the regulator enters the wet steam header and passes through large number of superheated tubes and finally comes to the superheater header. Then, the superheated steam goes to the engine. To accommodate the superheater tubes, some of the fire tubes are larger in diameter. There are about 157 fire tubes of 47.5 mm diameter and 24 fire tubes of 130 mm diameter. By superheating, the heat energy per unit mass of steam is increased and the thermal efficiency of the steam plant is considerably increased.

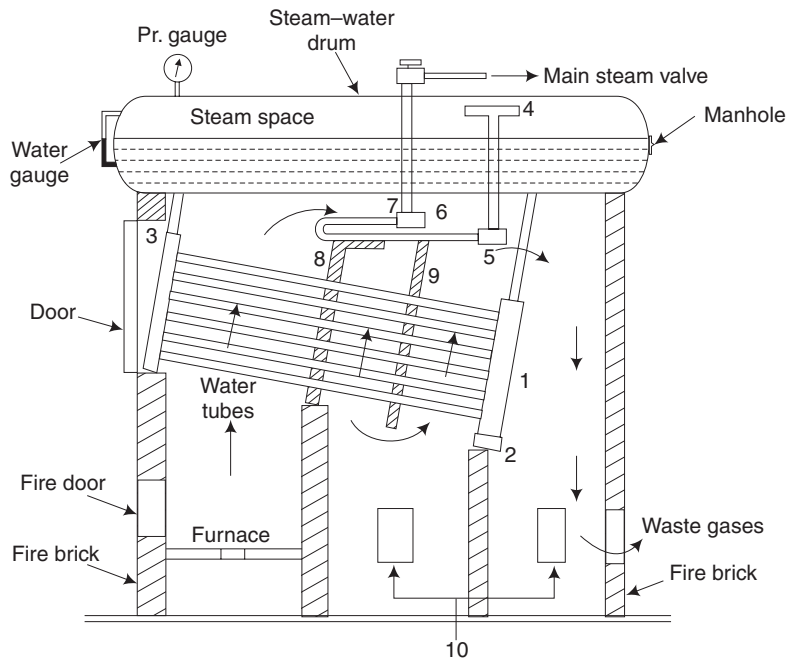
The boiler is fitted with a water gauge, a pressure gauge, a steam regulator, a safety valve, a whistle, and a fusible plug as shown in the sketch. In a locomotive boiler, the water gauge and pressure gauge will be mounted in the driver's cabin. The steam regulator can be operated by the driver from the cabin by a hand wheel. It should be noted that in railways, the use of steam engine is being reduced gradually and it is replaced by electric and diesel engines which have many advantages.



**Fig. 9.4** Locomotive boiler

## 9.6 BABCOCK AND WILCOX BOILER

This is a water-tube boiler. It consists of a steam water drum mounted on fire brick work. Hot gases from the furnace pass through a zigzag path through the fire brick baffles before going to the chimney through the damper. The damper controls the rate of burning and thereby the steam generation. The damper is operated by a chain passing through a set of pulleys. Water from the steam–water drum comes down to the downtake header and then goes to the uptake header through a large number of water tubes, inclined at about  $14^\circ$  for better circulation as shown in Fig. 9.5. It should be noted that there are many different types of Babcock and Wilcox boilers. One of the simpler types is shown in the sketch which is used for medium pressure and capacity.



1. Downtake header 2. Mud drum 3. Uptake header 4. Antipriming pipe 5. Wet steam header  
6. Superheater tubes 7. Superheater steam header 8. and 9. Fire brick baffles 10. Inspection doors

**Fig. 9.5** *Babcock and Wilcox boiler*

The wet steam comes to the wet steam header through an antipriming pipe. The antipriming pipe removes some moisture from the steam. Then, it passes through a large number of superheater tubes and reaches the superheater header. From the superheated header, it goes to the main steam valve and finally to the steam turbine.

At the end of the downtake header, a mud drum is connected from where impurities can be removed. As shown in the sketch, the boiler is provided with two inspection doors and other mountings such as the water gauge, the pressure gauge and the safety valve.

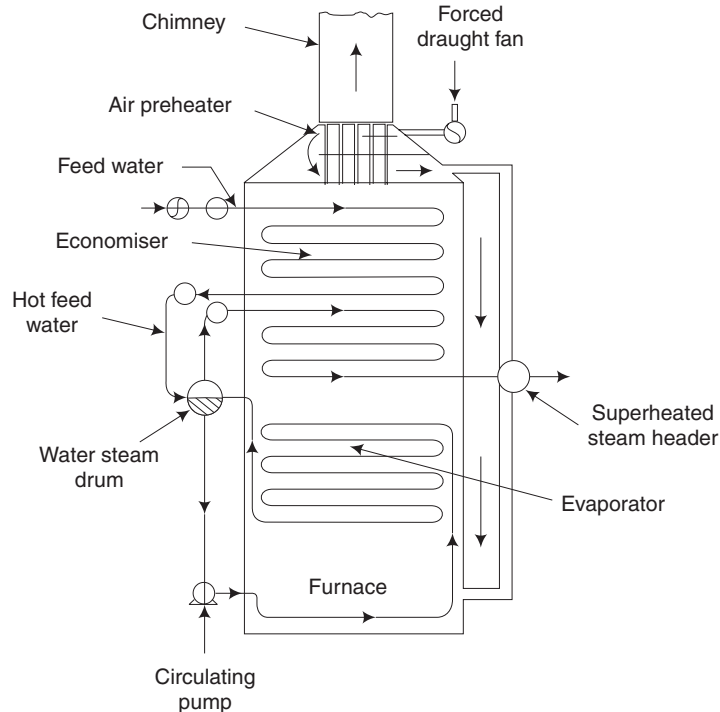
Normally, the furnace is provided with a moving grate. In a boiler provided with a moving grate, the rate of fuel burning can easily be controlled by changing the thickness of the fuel bed and also by changing the speed of the moving grate, otherwise called chain grate. Compared to a fire-tube boiler, evaporative capacity, the pressure of steam and the thermal efficiency of this boiler will be higher.

## 9.7 LAMONT BOILER

[May 2014, Regulation 2008]

This is one of the *high-pressure water-tube boilers working on forced circulation*. The circulation is maintained by a *centrifugal pump driven by a steam turbine using steam from the boiler*. Due to forced circulation, the rate of heat transfer and the evaporative capacity of the boiler are increased. This boiler is highly suitable for a power plant and this has a high thermal efficiency. Normally, in high-pressure boilers, either furnace oil or solid fuel in a pulverised form is used in the furnace. This boiler can produce steam upto a pressure of 150 atmosphere.

A simple layout sketch is given in Fig. 9.6. Water is circulated through the evaporator tubes. Hot gases from the furnace or the combustion chamber heat the water and evaporate into steam. Wet steam will come to the steam space in the steam-water drum. In the superheated tubes, the moisture from the wet steam is removed and also the temperature is considerably raised. In the economiser, the feed water is heated by means of waste gases before going to the chimney. Due to the feed water heating, thermal stress



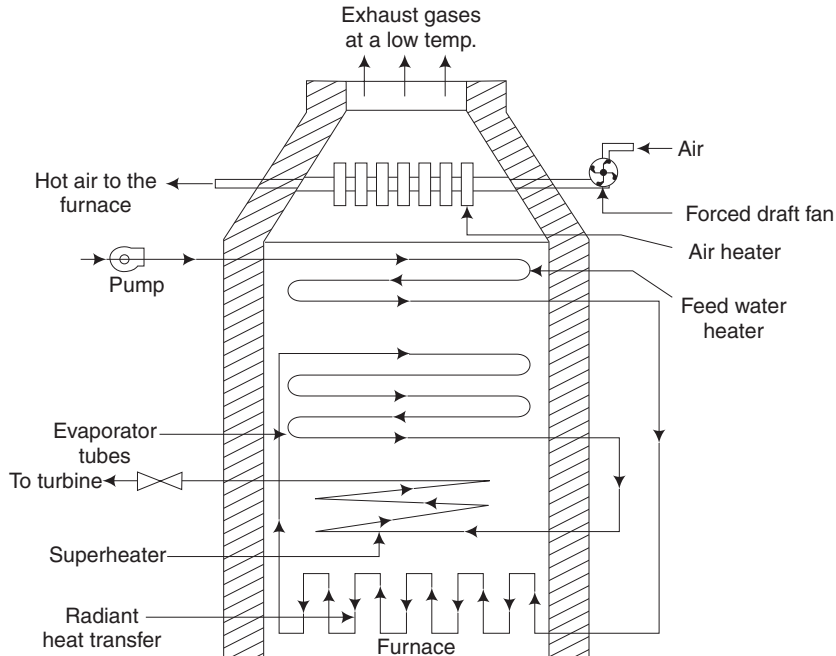
**Fig. 9.6** High pressure Lamont boiler

is reduced in various parts of the boiler. If any part is subjected to a large temperature difference suddenly, thermal stress will be induced in the part resulting in failure due to the development of cracks. Due to the use of heat in the waste gases, the thermal efficiency is further increased.

Due to high pressure of steam, the temperature of steam is increased. So the temperature of the furnace should also be increased by pre-heating the air. The method of pre-heating the air is shown in the sketch. The thickness of the drum and pipes should be more due to high pressure. In the boiler, bent tubes made of high quality steel are used. In the furnace, wall pipes are used to increase the capacity of the boiler and also to cool the furnace wall. This boiler is fitted with usual mountings such as a water gauge, a pressure gauge, safety valves and a blow-off valve. Normally, three safety valves are fitted in high-pressure boilers. The design, manufacture and erection of such high-pressure boilers are very difficult. It needs a large number of skilled personnel, good team work and large investment.

## 9.8 BENSON BOILER

This is very similar to the Lamont Boiler, but *there is no drum*. This boiler can produce steam, even at critical pressure (221.2 bar when the latent heat of steam is zero). Absence of the drum reduces the weight and cost. The arrangement of various components is given in Fig. 9.7.



**Fig. 9.7** Benson boiler

## **9.9 ADVANTAGES OF HIGH PRESSURE BOILERS**

1. High pressure steam out of the boiler will have higher heat energy per kg. So, power output from the turbine and the generator will be high.
2. The thermal efficiency of a high pressure boiler is much higher than the low pressure or medium pressure boilers.
3. Evaporative capacity of the boiler is high due to forced circulation of water.
4. The investment cost for each MW output will be less, by using a high pressure boiler.

## **9.10 CHARACTERISTICS OF A GOOD BOILER**

1. The boiler should be able to evaporate steam at the designed capacity, pressure and temperature.
2. Total cost of the boiler with all mountings and accessories should be low.
3. By having a higher thermal efficiency, the operational cost should be low.
4. The boiler should have provision for inspection of all the parts for cleaning and maintenance.
5. The boiler should have provision for automatic control of water level, pressure and temperature.
6. The parts should be able to withstand the fluctuations in pressure and temperature.
7. Transport and erection of the boiler at site should be easy and at the minimum cost.
8. The boiler should conform to all the safety regulations, as laid down in the Indian Boiler Act.

## **9.11 INDIAN BOILER ACT**

1. Unless the boiler is registered with the Chief Inspector of Boilers, it should not be put into operation.
2. Fitness Certificate should be obtained every year, from the Chief Inspector of Boilers.
3. The certificate should be displayed in the boiler room.
4. The boiler operator should be a trained person.
5. Any failure or accident should be immediately reported to the Chief Inspector.
6. Any violation of the act is punishable.

## 9.12 DIFFERENCES BETWEEN FIRE-TUBE AND WATER-TUBE BOILERS

[Nov 2010, Regulation 2010; May 2012, Regulation 2008]

Table 9.1

	<i>Fire tube boiler</i>	<i>Water tube boiler</i>
1.	Hot gases pass through the tubes, water surrounding them.	Water passes through the tubes, hot gases surrounding them.
2.	Used for low-pressure steam as the diameter of the shell is large. The pressure is restricted to about 10 bar.	Drum diameter is less and it can be used for medium and high pressure. Pressure of steam can even go up to about 100 bar.
3.	Used for industrial applications only due to low pressure.	<i>Used for power plants</i> where we need high pressure.
4.	More steam space and so pressure fluctuation is less.	Less steam space; pressure fluctuation is more when the steam is taken out.
5.	<i>Transport is difficult due to large shell diameter.</i>	Comparatively easier due to smaller drum.
6.	Less number of parts.	More number of parts.
7.	Fire tube will not be choked easily. Maintenance cost is less.	These boilers can be choked due to salt deposits. <i>Maintenance cost is more.</i>
8.	Water circulation is poor.	<i>Water circulation is better.</i>
9.	Thermal efficiency is low.	<i>Thermal efficiency is high.</i>
10.	Heating surface is less.	<i>Heating surface is more</i> due to large number of water tubes.
11.	Less skill is enough for the operation of the boiler.	More skill and controls are needed for the operation of the boiler.

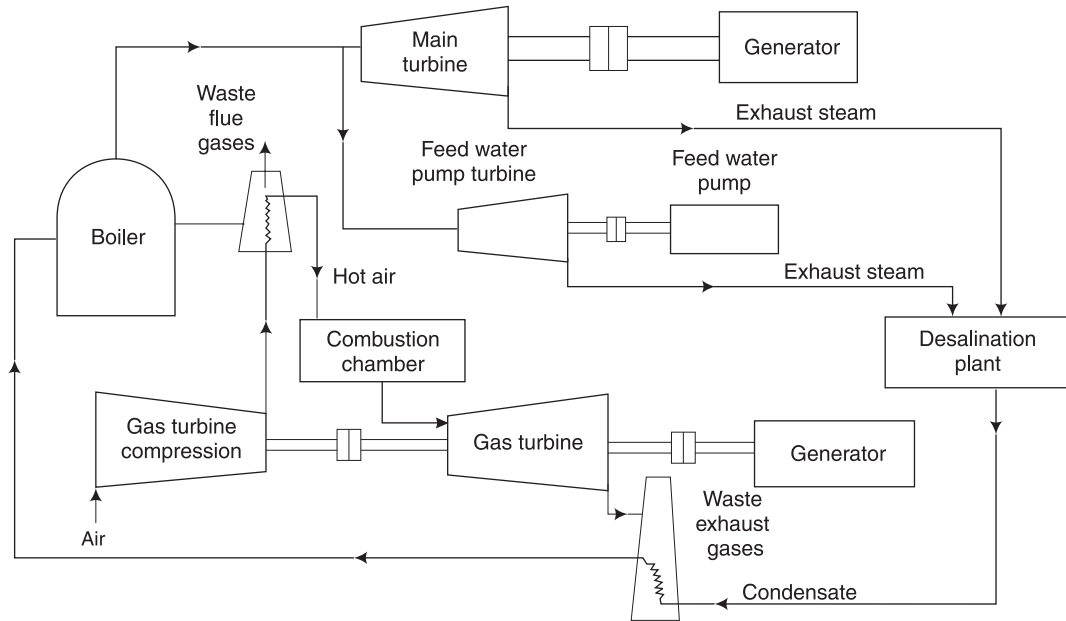
## 9.13 COGENERATION

It should be remembered that the thermal efficiency of any heat engine is rather low in the range of 15 to 35 per cent. When a heat engine is not able to convert all the input heat energy into useful mechanical power, it would be obviously rejecting energy as waste heat. So, a system will become more efficient if the waste heat is utilised for some useful purpose. Any scheme which combines electrical power generation with utilisation of heat for industrial processes and/or space heating is referred to as Combined Heat and Power (CHP) or Cogeneration. In such a scheme, energy wastage is reduced to the minimum thereby increasing the overall thermal efficiency.

Refer to Fig. 9.8. This cogeneration power plant employs both the steam turbine and a gas turbine for generating electric power. Because of recovery of heat from the flue gases of the boiler and the exhaust gases from the gas turbine, we obtain high overall thermal efficiency.

Steam is generated at high pressure and temperature in the boiler. Steam from the boiler is fed to the main steam turbine for generating electric power and also to a small turbine which drives the feed water pump. Both the turbines are back pressure, non-condensing type and the steam in the last stages of the turbines is fed into the desalination plant to purify sea water for getting soft water. Thus, it is noted that the desalination plant is operated by using the heat from the exhaust or waste steam from the turbines.





**Fig. 9.8** Cogeneration

In addition, the heat energy in the flue gases from the boiler instead of being wasted is used to preheat the compressed air used in the gas-turbine combustion chamber. The hot exhaust from the gas turbine is made to heat the condensate feed water from the desalination plant. The above two waste heat recoveries help in increasing the thermal efficiency of the power plant by reducing the fuel burnt in the gas turbine combustion chamber and also in the boiler for the same output power.

To site an example, in the case of a gas turbine power plant, heat from the exhaust gases could be made use of in the waste heat recovery boiler. Even after this, the gases could then be passed through an economiser to preheat the feed water for the boiler. Nowadays, this principle is made use of in many ways in thermal plants.

## 9.14 INTRODUCTION TO STEAM TURBINES

A steam turbine is a prime mover in which rotary motion is obtained by the gradual change of momentum of the steam. Steam turbines are primarily used to run alternators or generators in thermal power plants. It is also used to rotate the propeller of ships through reduction gearing. The design and manufacture of turbine blades are quite complicated due to which there are only a limited number of manufactures of steam turbines.

## 9.15 MAIN PARTS OF A STEAM TURBINE

**Nozzles** In steam turbines, normally, convergent–divergent type of nozzles are used. When steam flows through the nozzle, there is a pressure drop which is converted into

velocity or kinetic energy. The nozzle also guides the steam in the proper direction to strike the blades. The nozzles are kept very close to the blades to minimise the losses.

**Rotor** The rotor or runner consists of a circular disc fixed to a horizontal shaft. The rotor is mounted on suitable bearings.

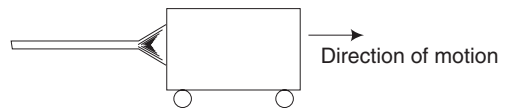
**Blades** On the periphery of the rotor, a large number of blades are fixed. The steam jet from the nozzle impinges on the surface of the blades due to which the rotor rotates. The surface of the blades is made smooth to reduce frictional losses.

**Casing** It is a steam tight steel casing which encloses the rotor, blades, etc. In a multistage turbine, the casing also accommodates the fixed blades. The casing helps the flow of steam and also protects the inner parts from any accident.

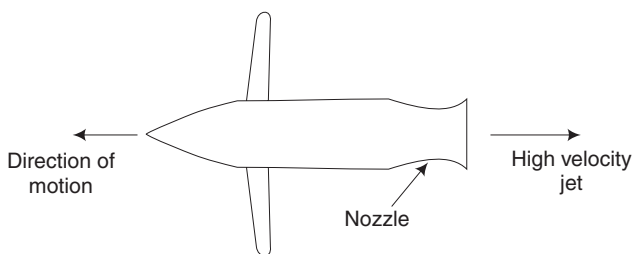
## 9.16 TYPES OF TURBINES

Steam turbines are classified as impulse turbines and reaction turbines. Differences between the terms impulse and reaction are explained below:

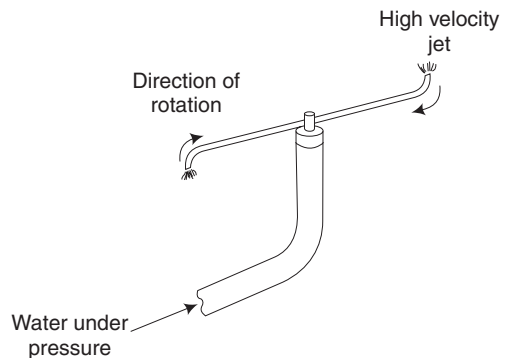
Impulse is the force obtained on an object when a jet of fluid strikes the object with a velocity as in Fig. 9.9(a). Reaction is the force obtained on an object when a fluid leaves the object with a higher relative velocity. Different examples of reaction are swimming, recoil of a gun, jet plane, ground wheel in fire works, lawn sprinkler, etc. In Fig. 9.9(b), the jet plane moves forward due to the reaction of the high velocity jet of hot gases from the nozzle. In Fig. 9.9(c), the lawn sprinkler rotates due to the reaction of the water jets.



**Fig. 9.9(a)** *Impulsive force of a fluid jet*



**Fig. 9.9(b)** *Jet Plane*

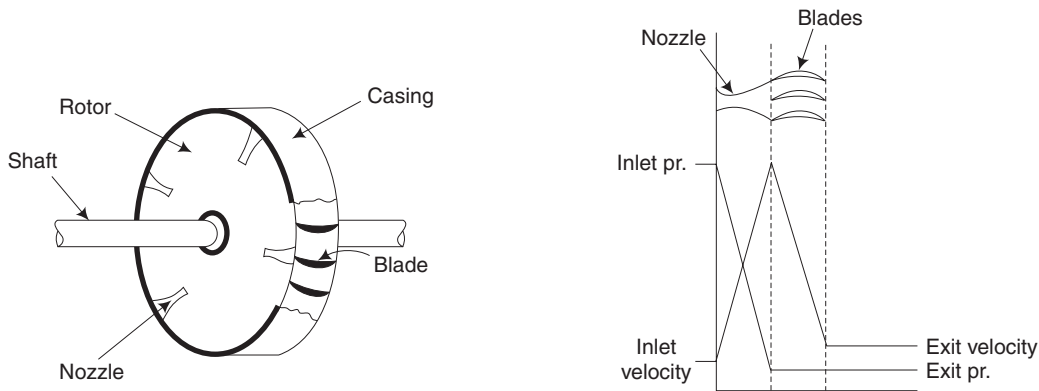


**Fig. 9.9(c)** *Lawn sprinkler*

## 9.17 WORKING OF A SINGLE-STAGE IMPULSE TURBINE (DE-LAVAL TURBINE)

First, the pressure energy is converted into velocity energy or kinetic energy by the expansion of steam through a set of nozzles. Normally, in steam turbines, we make use of convergent–divergent nozzles. The kinetic energy is converted into mechanical energy

with the help of moving blades fixed on a rotor. The rotor is connected to the output shaft. All the above-mentioned parts are enclosed in a casing as shown in Fig. 9.10(a). The pressure–velocity diagram, given in Fig. 9.10(b), is for a single-stage impulse turbine.



**Fig. 9.10(a)** *Single-stage impulse turbine* **Fig. 9.10(b)** *Pressure velocity diagram for a single-stage impulse turbine*

A simple or single-stage impulse turbine is only suitable for low-pressure steam. In case the steam pressure is high, when it expands in one set of nozzles, the outlet velocity of steam from the end of the nozzles will be too high. Due to the high velocity of the steam, the rotor will rotate at a very high speed. Such a high speed is not suitable for practical purposes. So, in practice, we make use of the multistage impulse turbines or compound impulse turbines.

## 9.18 COMPOUNDING OF IMPULSE STEAM TURBINES

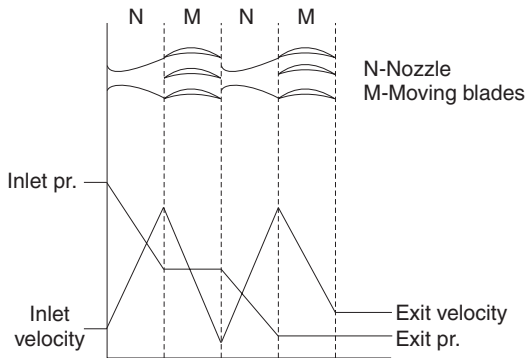
In multistage impulse turbines, there are three types of compounding, namely, pressure compounding, velocity compounding and pressure velocity compounding. In this section, the three types are discussed.

### 9.18.1 Pressure Compounding

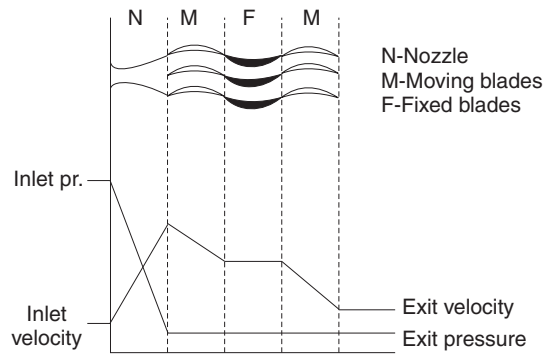
The pressure drop or expansion of steam is done in more than one set of nozzles and each set of nozzles is followed by a set of moving blades. The turbine is known as pressure compounded impulse turbine. A two-stage pressure compounding is shown in Fig. 9.11(a).

### 9.18.2 Velocity Compounding

Here the entire expansion of steam occurs in one set of nozzles resulting in a very high velocity at the outlet. The steam is then passed through several sets of moving blades, followed by fixed blades. Moving blades are fitted on the rotor while the fixed blades are fixed on the casing. The function of the fixed blades is to change the direction of steam and guide the steam in the proper angle to the next set of moving blades. A two-stage velocity compounding is shown in Fig. 9.11(b).



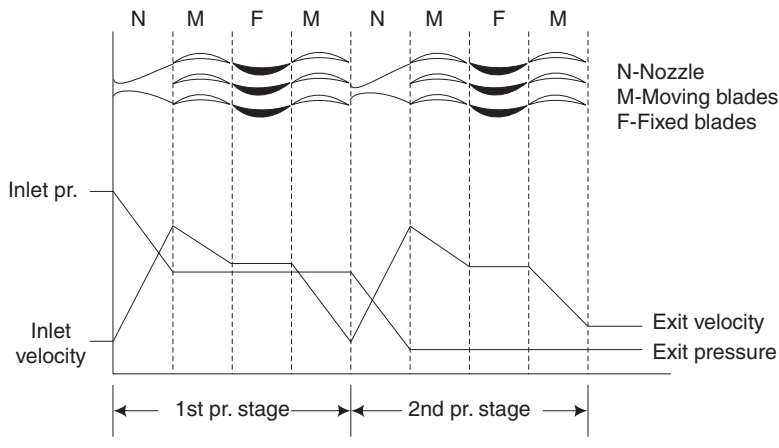
**Fig. 9.11(a)** 2-Stage pressure compounding



**Fig. 9.11(b)** 2-Stage velocity compounding

### 9.18.3 Pressure Velocity Compounding

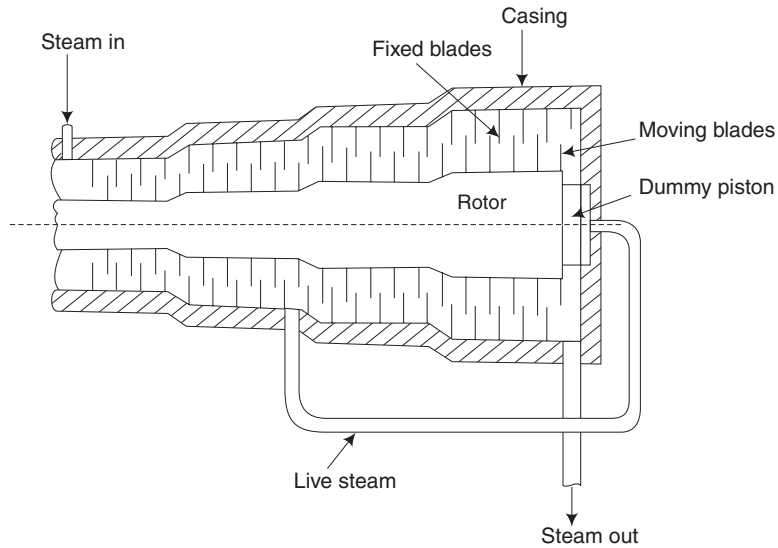
In power plants, pressure velocity compounding is more common. In this arrangement, for each pressure stage, there is a velocity staging. A two-stage pressure velocity compounding is shown in Fig. 9.11(c). In practice, there will be more than 20 stages in a power station.



**Fig. 9.11(c)** 2-Stage pressure velocity compounding

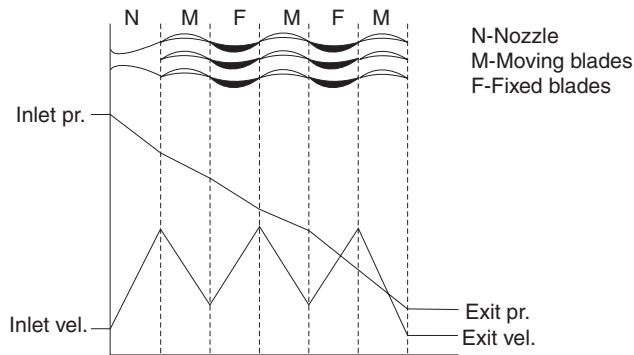
### 9.19 WORKING OF PARSON'S REACTION TURBINE

In this turbine, the power is obtained mainly by an impulsive force of the incoming steam and small reactive force of the outgoing steam. As shown in Fig. 9.12(a), this turbine consists of a rotor of a varying diameter. Moving blades are fixed on the rotor. The diameter of the casing also varies. Fixed blades are attached to the casing. Steam is admitted to the first set of moving blades through nozzles. The blades receive the impulsive force of the incoming steam. Then it goes to fixed blades which act as nozzles! Thus, steam flows alternatively through moving and fixed blades.



**Fig. 9.12(a)** *Parson's reaction turbine*

The shape of the moving blades is so designed to have also the reactive force, when the jet of steam is leaving the blades. For this, area of the outlet between the two moving blades will be less than the area at the inlet. In addition, there will be also some pressure drop even in the moving blades. Thus, we have a continuous pressure drop in the fixed as well as in the moving blades as in Fig. 9.12(b), in reaction turbines.



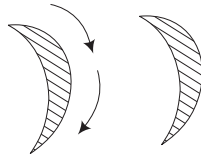
**Fig. 9.12(b)** *Pressure drop in a reaction turbine*

The diameters of the rotor and casing gradually increase to accommodate the increasing volume of steam at reduced pressure. The size of the blades also increases in the direction of flow. A dummy piston is used to balance the axial thrust of the rotor by allowing live steam to act on one side of the dummy piston, opposite to the direction of steam flow. In case, the axial thrust is not balanced properly, there will be undue and uneven wear in the turbine shaft.

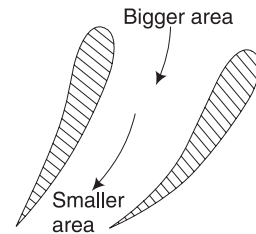
## 9.20 DIFFERENCES BETWEEN IMPULSE AND REACTION TURBINES

**Table 9.2**

<i>Impulse turbine</i>	<i>Reaction turbine</i>
1. Power is obtained only due to the impulsive force of the incoming steam.	Power is due to both the impulsive force of the incoming steam and due to the reactive force of the outgoing steam.
2. Pressure drop is only in the nozzle or in the fixed blades which act as nozzles. There is no pressure drop in moving blades.	Pressure drop is in the fixed and also in the moving blades.
3. The relative velocity of steam at inlet and outlet of the moving blades are equal.	The relative velocity of steam at outlet is higher to get the reactive force.
4. Blades are symmetrical.	Blades are not symmetrical.
5. Inlet area of moving blades is equal to the outlet area as in Fig. 9.13 (a).	Outlet area of the moving blades is smaller than the inlet area as shown in Fig. 9.13 (b), to have the nozzle action.



**Fig. 9.13(a)** *Moving blades of impulse turbine*



**Fig. 9.13(b)** *Moving blades of reaction turbine*

### Short-Answer Questions

1. Answer the following questions:
  - (a) State some of the applications of steam boilers.
  - (b) Classify different steam boilers.
  - (c) What are the requirements of a good boiler?
  - (d) What are water walls?
  - (e) What are the specific advantages of water-tube boilers?
  - (f) Give three examples each of boiler mountings and boiler accessories.
  - (g) What are the aims of pre-heating of air in a boiler?
  - (h) How does a fusible plug function as a safety device?
  - (i) What is meant by superheated steam?
  - (j) What are the advantages of superheating of steam?
  - (k) What is an economiser?
  - (l) Why should the boiler feed water be soft?
  - (m) What are the commercial fuels used in boilers?

- (n) What is meant by cogeneration?
  - (o) What are the essential components of a cogeneration plant?
  - (p) What are the main parts of a steam turbine?
  - (q) What is the function of a steam nozzle?
  - (r) What are the two classifications of steam turbine? Give examples.
  - (s) Define the terms impulse and reaction with examples.
  - (t) Draw pressure-velocity diagram for a single stage impulse turbine.
  - (u) What are the three types of compounding in impulse steam turbines?
  - (v) Define the terms:
    - (i) pressure compounding
    - (ii) velocity compounding
  - (w) State any two important differences between the impulse and reaction steam turbines.
2. Fill up the blanks with suitable word/words:
- (a) Cochran boiler is a \_\_\_\_\_ boiler and Babcock and Wilcox boiler is a \_\_\_\_\_ boiler.
  - (b) The two types of draught employed in boilers are \_\_\_\_\_ and \_\_\_\_\_.
  - (c) \_\_\_\_\_ and \_\_\_\_\_ are modern high pressure boilers.
  - (d) The two types of superheaters used in high pressure boilers are \_\_\_\_\_ and \_\_\_\_\_.
  - (e) Rotary motion of a turbine is obtained by the gradual change of \_\_\_\_\_ of steam.
  - (f) When steam flows through nozzle, \_\_\_\_\_ is converted into \_\_\_\_\_.
  - (g) Pressure energy is converted into kinetic energy by the \_\_\_\_\_ of steam through a nozzle.
  - (h) \_\_\_\_\_ is converted into \_\_\_\_\_ with the help of moving blades.
3. Choose the correct answer from the following:
- (a) The water tubes in a Babcock and Wilcox boiler are
    - (i) vertical
    - (ii) horizontal
    - (iii) inclined
    - (iv) none of the above
  - (b) The draught produced in locomotives is
    - (i) induced
    - (ii) forced
    - (iii) both
    - (iv) none of the above
  - (c) An economiser in a boiler
    - (i) increases thermal efficiency
    - (ii) increases fuel consumption
    - (iii) expands steam
    - (iv) none of the above

- 
- (d) The condition of steam in the boiler drum is usually
- (i) superheated
  - (ii) super saturated
  - (iii) wet
  - (iv) none
- (e) In an impulse turbine, when steam flows through the moving blades,
- (i) velocity decreases
  - (ii) velocity increases
  - (iii) pressure decreases
  - (iv) pressure increases
- (f) De-Laval turbine is a
- (i) simple impulse turbine
  - (ii) simple reaction turbine
  - (iii) pressure-compounded turbine
  - (iv) velocity-compounded turbine
- (g) In reaction turbine, when steam flows through the fixed blades,
- (i) pressure and velocity both increase
  - (ii) pressure and velocity both decrease
  - (iii) pressure decreases, while velocity increases
  - (iv) pressure decreases, while velocity decreases
- (h) In pressure compounded impulse turbine
- (i) pressure drop for each stage is equal
  - (ii) pressure drop takes place in nozzle
  - (iii) both (i) and (ii)
  - (iv) none of the above
- (i) In velocity compounded impulse turbine, when steam flows through the second row of moving blades,
- (i) velocity increases
  - (ii) velocity decreases
  - (iii) velocity remains constant
- (j) In steam turbines, blades are
- (i) straight
  - (ii) curved
  - (iii) circular
  - (iv) none of the above
4. State whether the following statements are true or false:
- (a) Heating of steam above saturation temperature is called superheating.
  - (b) Cochran boiler is a horizontal water-tube boiler.
  - (c) Fusible plug is employed to make a spark.
  - (d) All fire-tube boilers are high pressure boilers.
  - (e) Formation of scale on a boiler tube decreases its life.
  - (f) Pressure drop is converted into mechanical energy in nozzle.
  - (g) Pressure falls gradually in reaction turbines in fixed and moving blades.
  - (h) Turbine blades are circular.
  - (i) Steam nozzle converts heat energy of steam into pressure energy.



- (j) When the cross section of a nozzle first decreases from its entrance to throat and then increases from its throat to exit, the nozzle is known as convergent nozzle.
- (k) Steam enters the steam nozzle at high pressure and high velocity.
- (l) Steam leaves the nozzle at high pressure and high velocity.
- (m) The De-Laval turbine is a multi-rotor impulse turbine.
- (n) In axial flow turbine, the direction of steam flow with respect to turbine axis is at right angle.
- (o) In reaction turbine, the driving force is only reaction force.



# Chapter 10

## PUMPS

### 10.1 APPLICATION OF PUMPS

Pumps have wide applications in pumping water, fuel, chemical and viscous fluids like lubricants. Water pumps are used to pump water from borewells or open wells for residential buildings and agricultural purposes. They are also used for cooling of petrol engines, diesel engines, gas turbines, exhaust steam in condensers in power plants. Special high-pressure injector pumps are used to pump water in steam boilers, during operation.

Fuel pumps and lubricating oil pumps are used for the operation of IC engines, gas turbines, steam power plants, etc. They also have immense industrial applications.

To name a few, in automobile industry, pumps are used for automatic transmission, power steering, hydraulic brake, etc. In the field of agriculture, pumps are used for hydraulic-driven farm equipments. Also, in the field of material handling, pumps are used in earth-moving equipment, cranes, lifts, etc.

In municipalities and corporations, special pumps are used for sewage disposal.

**Table 10.1** Types of Pumps and their Applications

[May 2015, Regulation 2008]

<i>Type of Pumps</i>	<i>Applications</i>	
1. Reciprocating pumps 2. Centrifugal pump	To pump water to overhead tanks in buildings and also for agriculture	
3. Compressor pumps 4. Submergible pumps		
5. Vane pumps 6. Gear pumps 7. Injector pump 8. Different types of fuel pumps 9. Screw pumps		To pump semi-viscous liquids To pump viscous oil for lubrication To pump boiler feed water during its operation To pump petrol or diesel oil in IC engines To pump liquid mixed with solid materials.

In this text, however, only the first two types will be dealt with.

## 10.2 CLASSIFICATION

Broadly, pumps are classified as

1. Reciprocating pumps
2. Centrifugal pumps
3. Compressor pumps
4. Submergible pumps

But, in this textbook, only the first two types will be dealt with.

## 10.3 RECIPROCATING PUMPS

[May 2012, Regulation 2008]

The reciprocating pumps are classified as

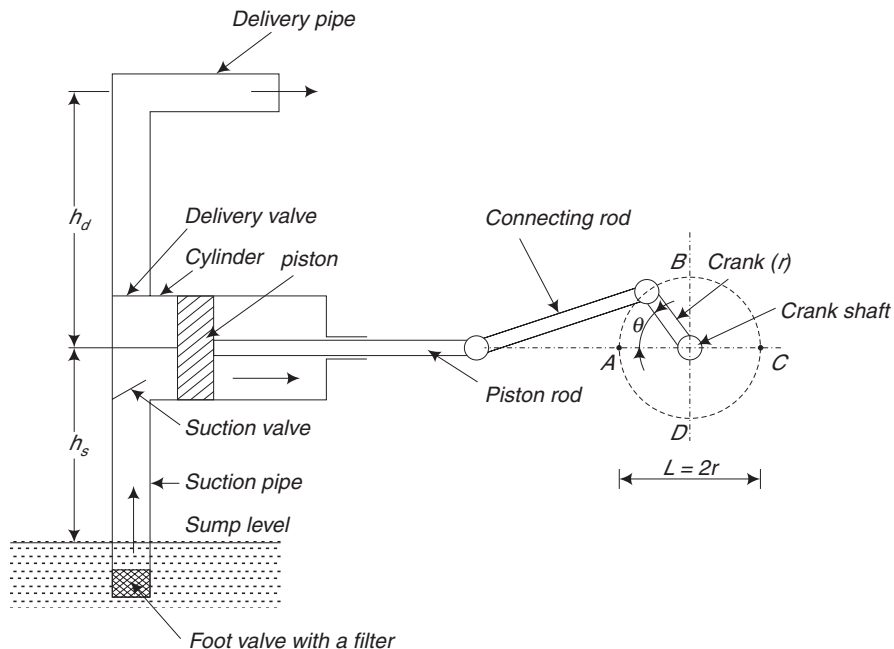
1. Single acting
2. Double acting

### 10.3.1 Working of a Single-Acting Reciprocating Pump

[Nov 2009; May 2012; Nov, 2013, Regulation 2008; May 2014, Regulation 2013]

As in Fig. 10.1, it consists of the following parts:

1. Cylinder with a piston



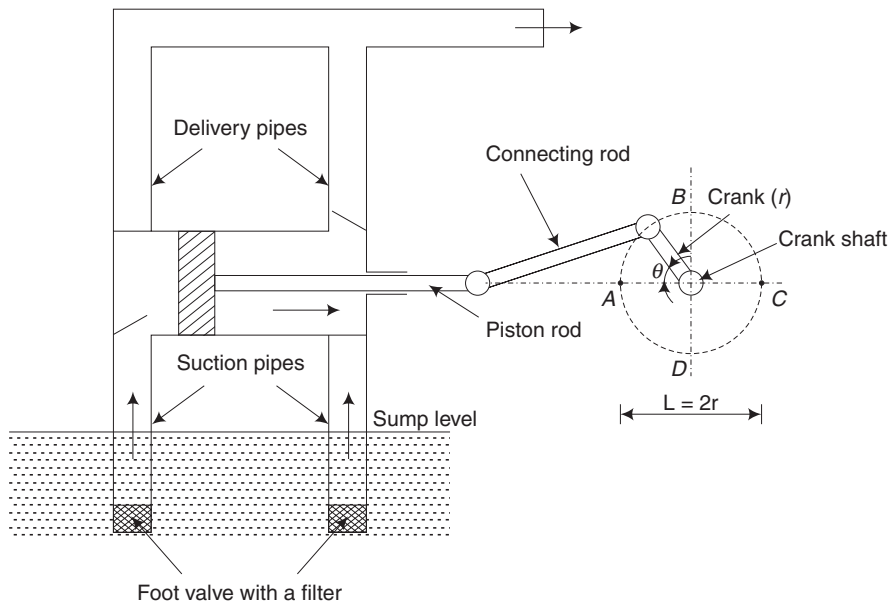
**Fig. 10.1** Single-acting reciprocating pump

2. Piston rod, connecting rod, crank and crank shaft
3. Suction pipe with a foot valve (one-way valve) and filter
4. Delivery pipe
5. Suction valve
6. Delivery valve

The crankshaft is coupled to an electric motor or a diesel engine. When the motor or engine is started, the piston moves to and fro inside the cylinder. When the piston moves right in the direction of arrow, a vacuum will be produced in the cylinder due to which the suction valve opens and the water is sucked up from the pump and enters the cylinder through the suction pipe. When the piston moves in the left direction, pressure is created in the water due to which the delivery valve is opened and water is forced into the delivery pipe and finally to the required height.

### 10.3.2 Working of a Double-Acting Pump

In the double-acting pump, water acts on both sides of the piston. There are two suction pipes and two delivery pipes, as shown in Fig. 10.2. When there is a suction stroke on one side of the piston, there will be a delivery stroke on the other side of the piston. Thus, for each revolution of the crankshaft, there will be two delivery strokes and so, double the amount of water is delivered by this type of pump.



**Fig. 10.2** *Double-acting reciprocating pump*

### 10.3.3 Differences between Single-Acting and Double-Acting Pumps

[May 2012, Regulation 2008]

	<i>Single Acting</i>	<i>Double Acting</i>
1.	One suction pipe only	Two suction pipes
2.	One delivery pipe only	Two delivery pipes
3.	Water acts on one side of the piston	Water acts on both sides of the piston
4.	During one rotation of the shaft, there is only one delivery stroke	Two delivery strokes
5.	Water pumped will be less	Double the amount
6.	Power of the motor or engine is less	Higher power is required
7.	Cost is less	Cost is more

### 10.3.4 Discharge of Reciprocating Pumps

Consider a single acting reciprocating pump. Let  $L$  be the length of the stroke of piston,  $A$  be the cross-sectional area of the piston, and  $N$  be the number of revolutions, per minute of the crank. Then,

The discharge of water per stroke =  $LA$

and discharge of the pump per second,  $Q = LAN/60$

If the pump is a double acting reciprocating pump, the discharge is taken to be double the discharge than that of a single acting pump (if the size of the piston rod is neglected). This is due to the reason that, in a double acting pump, the water is sucked on one side of the piston and delivered from the other side during the same stroke. These two processes (i.e., suction on one side and delivery from the other) are reversed during the return stroke. If the size of the piston rod is neglected, then discharge of a double acting reciprocating pump can be calculated as follows:

the discharge of the pump per second,  $Q = 2LAN/60$

#### **Slip of the Pump**

[May 2012, Regulation 2008]

One of the important terms in estimating the discharge of reciprocating pumps is the Slip of the pump. The discharge of a single acting and double acting reciprocating pumps can be obtained from the equations given above. But in practice, the actual discharge is less than the theoretical discharge. The Slip of the pump can be defined as the difference between the theoretical discharge and actual discharge.

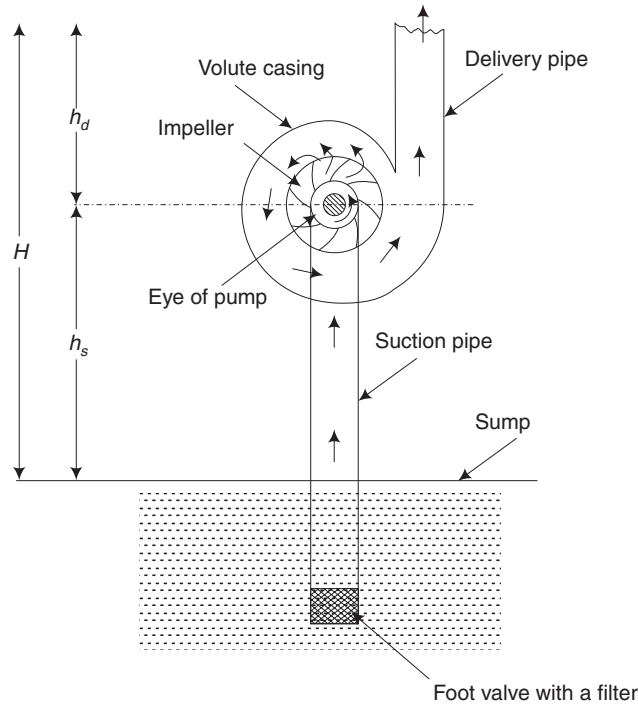
## 10.4 CENTRIFUGAL PUMPS

[Nov 2009; May 2014, Regulation 2008; May 2014, Regulation 2013]

The main parts of a centrifugal pump are given in Fig. 10.3. It consists of

1. Impeller
2. Casing

3. Suction pipe fitted with a foot valve (one-way valve) and filter; the foot valve will not allow the water to come down
4. Delivery pipe



**Fig. 10.3** Main parts of a centrifugal pump with volute casing

### 10.4.1 Impeller

[May 2015, Regulation 2013]

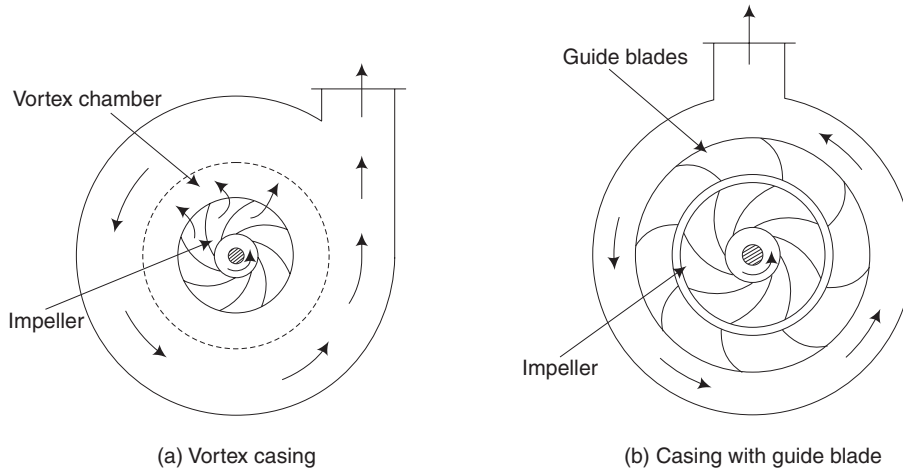
The impeller is a metallic disc fitted with a number of curved vanes. Initially, water will be poured inside the casing and the process is called priming. So, after priming, the impeller will be immersed in water inside the casing. When the impeller is rotated by an electric motor or an engine, it will produce centrifugal force due to which kinetic energy or velocity energy will be produced in the water. This is finally converted into pressure energy due to which water is pumped up, as explained further.

### 10.4.2 Casing

The casing surrounds the impeller. The area between the impeller and casing is gradually increasing, till the delivery pipe. Due to this, the velocity of flow of water will be gradually decreased. Due to the reductions in kinetic energy, the pressure energy of water is increased. The following three types of casings are normally used.

### ***Volute Casing***

The gap between the impeller and the casing is comparatively less, as in Fig. 10.3. So, eddies or turbulence will be formed which reduces the efficiency of the pump. However, the size of the casing will be small and the cost will be less.



**Fig. 10.4** *Different types of casing for centrifugal pumps*

### ***Vortex Casing***

As shown in Fig. 10.4(a), the space between the impeller and the casing is increased by introducing a circular chamber. As formation of eddies are reduced, the efficiency of the pumps with vortex casing is increased.

### ***Casing with Guide Vanes or Diffuser Casing***

In this type, the impeller is surrounded by a set of guide vanes or diffuser as in Fig. 10.4(b). The shape of the guide vanes should be carefully designed to ensure that the water flow from the impeller enters the guide vanes without shock. Gradual increase in area of guide vanes reduce the velocity of flow resulting in pressure increase.

## **10.4.3 Differences between Reciprocating Pump and Centrifugal Pump**

	<i>Reciprocating pumps</i>	<i>Centrifugal Pump</i>
1.	Can be used for high head	Medium head
2.	Can pump less quantity only	Large quantity can be pumped
3.	Discharge is not continuous	Continuous flow
4.	Cost is high	Cost is low
5.	Cannot run at high speed	Can run at high speed
6.	Cannot pump viscous fluid	Can pump viscous fluid.



#### 10.4.4 Cavitation

[Nov 2012, Regulation 2008]

Cavitation is the formation of bubbles or cavities in liquid, developed in areas of relatively low pressure around an impeller. The collapsing of these bubbles trigger intense shockwaves inside the pump, causing significant damage to the impeller and/or the pump housing. Cavitation may be classified in ways as follows:

**Suction Cavitation** When a pump is operating under low pressure or vacuum conditions, suction cavitation occurs. The pump is not receiving enough flow of fluid. Cavitation is indicated by formation of bubbles, which may lead to the formation of cavities at the eye of the impeller. As the bubbles carry over to the discharge side of the pump, the fluid conditions change, compressing the bubble into liquid and causing it to implode against the face of the impeller. The cavitation affected impeller will have small and large pits and will look like a sponge. Possible causes of suction cavitation are (i) Clogged filters or strainers, (ii) Blockage in the pipe, (iii) Pump is running too far right on the pump curve and (iv) Poor piping design.

**Discharge Cavitation** If a pump's discharge pressure is extremely high, or runs at less than 10% of its best efficiency point (BEP), discharge cavitation may occur. The high discharge pressure makes it difficult for the fluid to flow out of the pump, so it circulates inside the pump. Liquid flows between the impeller and the housing at very high velocity, causing a vacuum at the housing wall and the formation of bubbles. The implosion of those bubbles trigger intense shockwaves, causing premature wear of the impeller tips and pump housing. As the worst case, discharge cavitation can cause the breakage of the impeller shaft. Possible causes of discharge cavitation are (i) Blockage in the pipe on discharge side, (ii) Clogged filters or strainers, (iii) Running too far left on the pump curve and (iv) Poor piping design.

#### Short-Answer Questions

1. List at least five fluids, which can be pumped.
2. How are the pumps classified?
3. What are the different applications of pumps?
4. What is the function of a foot valve in the suction pipe?
5. Tabulate the differences between single-acting and double-acting reciprocating pumps.
6. What are the main components of a reciprocating pump?
7. Write the expressions to estimate the theoretical discharge of single and double acting reciprocating pumps.
8. Define the term slip corresponding to the reciprocating pumps.
9. In a centrifugal pump, compare volute casing and vortex casing.
10. What is priming?

11. Tabulate the differences between the reciprocating pump and centrifugal pump.
12. What are the main components of a centrifugal pump?
13. Write a note on cavitation.

# Chapter 11

## IC ENGINE

### 11.1 INTRODUCTION

[Nov 2012, Regulation 2008]

Heat engines convert heat energy to mechanical energy. The engines use heat obtained by burning some fuel. As the source of heat energy from combustion of a fuel, engines are classified as External Combustion (EC) engines and Internal Combustion (IC) engines. In the EC engines, combustion of the fuel takes place outside the engine and in the IC engines, combustion of the fuel takes place inside the engine. Popular External Combustion (EC) engines are the steam engines that are used in locomotives and ships. Petrol engines and diesel engines are classified as internal combustion engines, abbreviated as IC engines. These engines have extensive applications in transport by road, rail, sea and air. These are made use of in motorcycles, scooters, cars, buses, lorries, railway engines, ships and aero engines. IC engines have made a major revolution in transport. These engines have also contributed to the development of agriculture through tractors, harvesters, etc. IC engines also play a vital role in major construction work through bulldozers and other equipment. Thus, development of IC engines has made a great contribution to human comfort and to the tremendous progress of agriculture and industry. It is surprising and rather unbelievable that about 120 years back, there was no IC engine at all in any part of the world. Obviously, due to the rapid development in science and technology in the recent years, the present generation enjoys more comfort than our ancestors.

But, the world is going to face a crisis for fuel in about 50 years when the crude oil in the Gulf countries is expected to be exhausted. Under these circumstances, leading automobile companies in the world are investing huge amounts in research and development to find alternate source to replace diesel and petrol.

### 11.2 CLASSIFICATION OF IC ENGINES

[May 2012; May 2015, Regulation 2013; Apr 2015, Regulation 2013]

IC engines can be classified as follows:

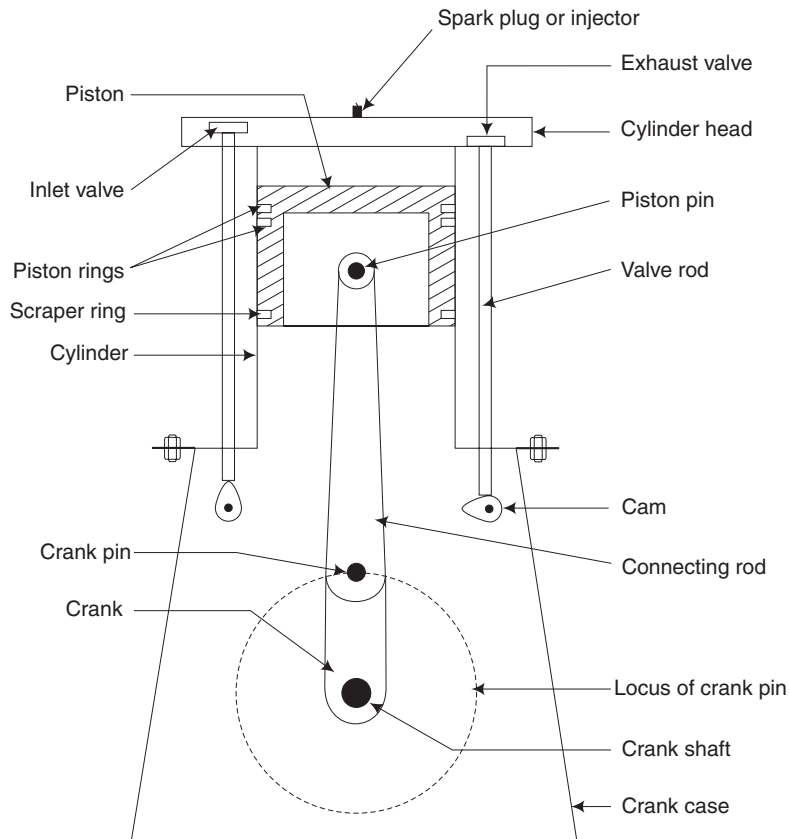
1. According to the type of fuel used
  - (a) Petrol engine
  - (b) Diesel engine

2. According to the cooling system
  - (a) Air-cooled engine
  - (b) Water-cooled engine
3. According to the cycle of operation
  - (a) Four-stroke cycle engine
  - (b) Two-stroke cycle engine
4. According to the charge pressure
  - (a) Naturally aspirated engine
  - (b) Supercharged/turbocharged engine for higher capacity
5. According to the number of cylinders
  - (a) Single-cylinder engine
  - (b) Multicylinder engine

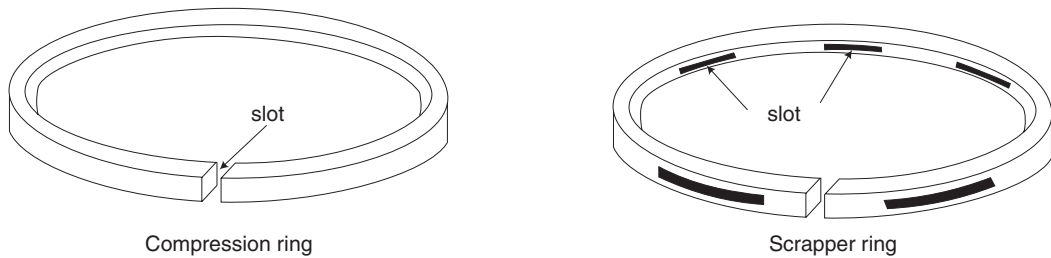
### 11.3 MAIN COMPONENTS OF IC ENGINES

[May 2009, 2012; Nov 2012, Regulation 2008; May 2014; Apr 2015, Regulation 2013]

A simple sectional elevation of a 4-stroke engine is given in Fig. 11.1(a) indicating the various components.



**Fig. 11.1(a)** *Four-stroke engine*



**Fig. 11.1(b)** *Piston rings*

**1. Cylinder** The cylinder allows the piston to move to and fro. The cylinder is made of cast iron or steel or an aluminium alloy. Sometimes, a liner made of alloy cast iron is inserted into the cylinder which can be replaced when worn out.

**2. Cylinder Head** It is fitted on the top of the cylinder. A gasket is provided between the cylinder and the cylinder head to prevent the leakage of hot gases. The cylinder head also accommodates the inlet valve, the exhaust valve, and the spark plug or injector.

**3. Piston** It transmits the force exerted by the burning gases to the connecting rod and finally to the crank shaft. The piston is usually made of cast iron or steel or aluminium alloy. There is an interesting and complex science behind the design and manufacture of a piston of an IC engine. The diameter of a piston in a large marine engine is about 1 m.

**4. Piston Rings** Two different types of piston rings are housed in the circumferential grooves provided on the outer surface of the piston. The function of upper rings known as compression rings is to provide gas-tight sealing to maintain the compression pressure inside the cylinder and to prevent the leakage of burnt gases into the crank case. The function of the lower rings is to scrap the used lubricating oil into the crank case. These rings are called scraper rings.

**5. Connecting Rod** This transmits the force from the piston to the crank shaft. It also helps in converting the reciprocating motion of the piston into the rotary motion of the crank shaft. For the lubrication of the piston pin in the connecting rod, a small hole is provided from the big end to the small end. The small end of the connecting rod is attached to the piston by a gudgeon pin.

**6. Crank Shaft** Great care should be taken in the proper design of the crank shaft. Alloy steels are used for the crank shaft to withstand the high stress and strain. The crank shaft is provided with suitable holes to help in the lubrication system. The crank case serves as a sump for the lubricating oil.

**7. Flywheel** It is mounted on the crank shaft. The flywheel stores the excess energy during the power stroke of the engine and helps the movement of the piston during the remaining idle strokes.

**8. Cams** Properly designed cams control the opening and closing of the inlet and exhaust valves in the case of four-stroke engines. Cams are rotated by a cam shaft driven by the crank shaft through gears.

**9. Compression Ratio** The compression ratio is defined as  $\frac{V_s + V_c}{V_c}$  where  $V_s$  is the stroke volume, and  $V_c$  is the clearance volume.

This is further explained by the following example.

[Nov 2008, 2009; May 2013; Apr 2015, Regulation 2008]

*Stroke is the length covered by the piston's movement from TDC to BDC or in 180 degree turn, of the crank shaft. It is also the diameter of the crank. A motorcycle has a cylinder diameter of 4.6 cm and a stroke of 4.2 cm. If the clearance volume is 12.2 cc, determine the compression ratio  $r$ .*

$$\text{Stroke volume} = \frac{\Pi d^2}{4} \times l = \frac{\Pi(4.6)^2}{4} \times 4.2 = 67.8 \text{ cc}$$

$$\text{The compression ratio } r = \frac{V_s + V_c}{V_c} = \frac{67.8 + 12.2}{12.2} = 6.552$$

## 11.4 WORKING OF A FOUR-STROKE PETROL ENGINE

[Nov 2008, 2009; May 2013; Apr 2015, Regulation 2008]

Figure 11.2 depicts the working of a typical four-stroke petrol engine. The different strokes are described in this section.

**1. Suction Stroke** During this stroke, the inlet valve is kept opened and the exhaust valve is closed. The piston comes down to the bottom dead centre (BDC) from the top dead centre (TDC). Pressure in the cylinder will be slightly less than the atmospheric

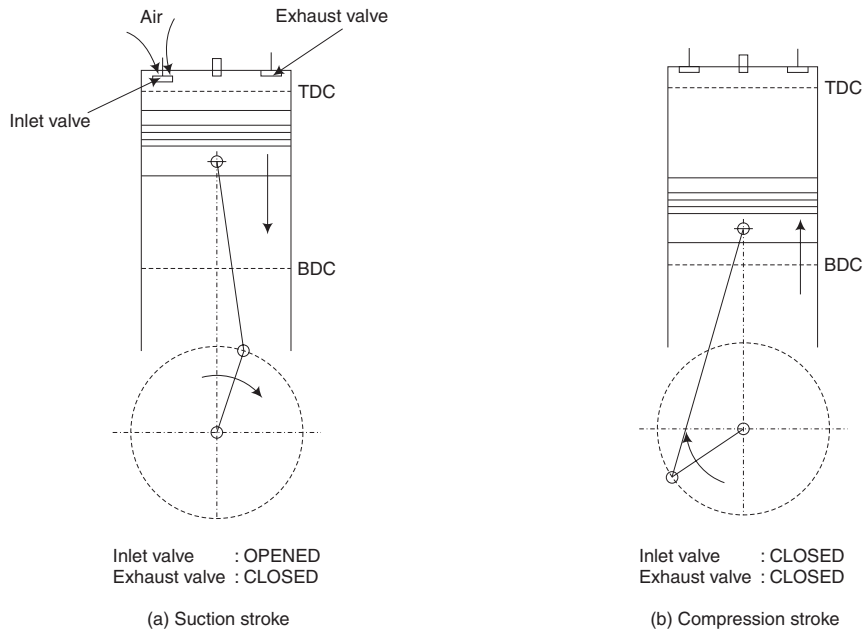
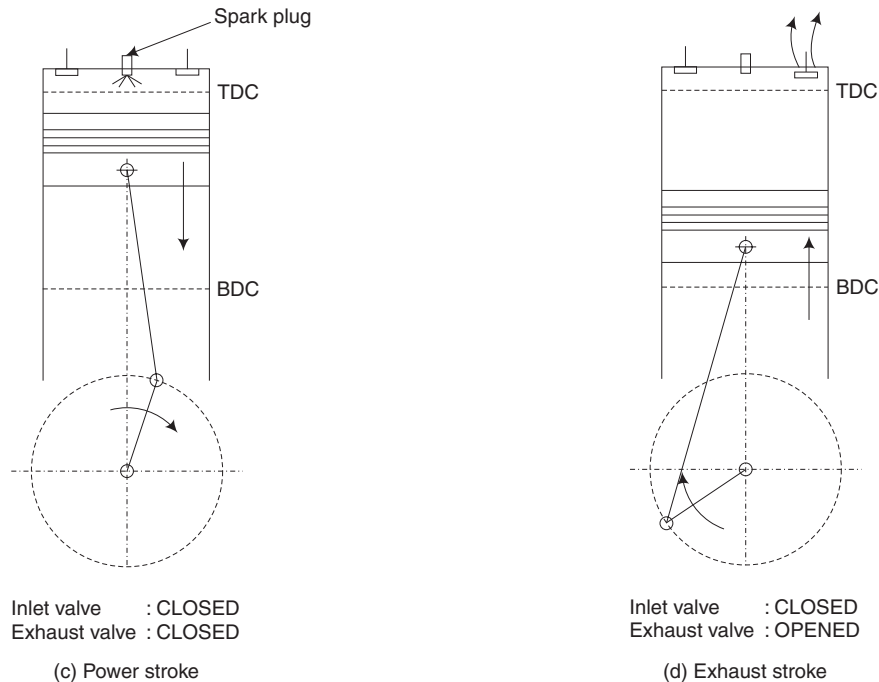


Fig. 11.2 (contd.)



**Fig. 11.2** 4-stroke cycle petrol engine

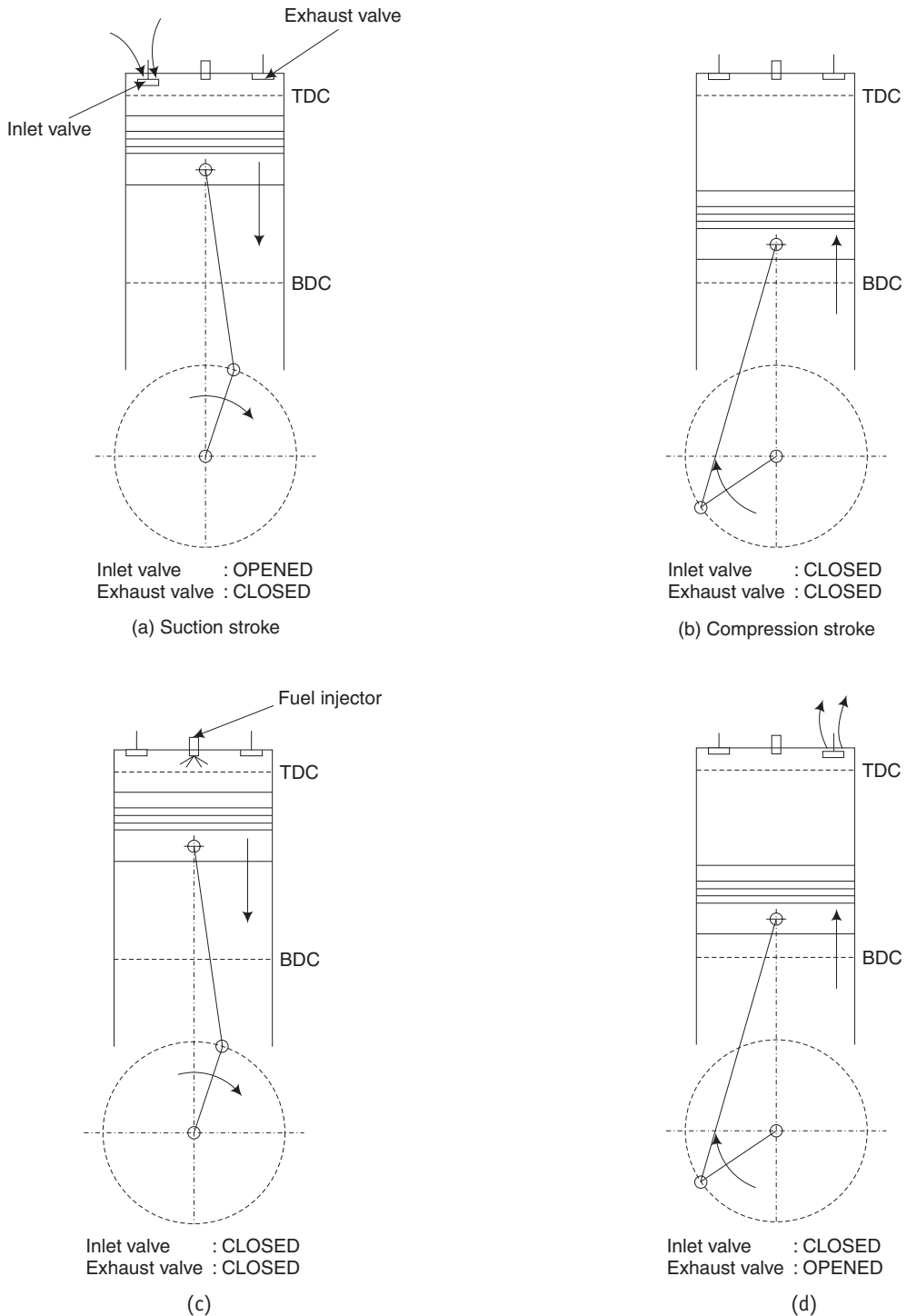
pressure. Petrol–air in the correct proportion from the carburetter is drawn inside the engine cylinder through the inlet valve.

**2. Compression Stroke** In this stroke, both the inlet and exhaust valves are kept closed. The mixture of petrol–air is compressed when the piston moves up to TDC. The compression ratio varies from 7–10 for petrol engines. The ratio between the cylinder volume before compression to the volume after compression is known as the compression ratio. At the end of the compression stroke, a spark is produced at the spark plug due to which combustion starts resulting in high pressure and temperature which are comparatively less than that of a diesel engine.

**3. Working or Power Stroke** During this stroke, both valves are kept closed. The piston is pushed down from TDC to BDC. The force above the piston is transmitted to the crank shaft through the connecting rod and crank mechanism. Excess energy due to the combustion is stored in the flywheel which helps for the operation of three idle strokes.

**4. Exhaust Stroke** During the stroke, the exhaust valve is kept opened and the inlet valve is kept closed. The piston moves up from BDC to TDC. The waste gases are sent out through the exhaust valve and the cycle is repeated. This is also called scavenging.

During these four strokes, the crank shaft will make two revolutions. The thermal efficiency of a four-stroke engine is higher compared to a two-stroke cycle engine. Most of the cars operate on a 4-stroke cycle.



**Fig. 11.3** 4-stroke cycle diesel engine



## 11.5 WORKING OF A FOUR-STROKE DIESEL ENGINE

[Nov 2010, Regulation 2008; Apr 2015, Regulation 2013]

This is similar to the operation of a 4-stroke petrol engine (refer to the earlier sketch). Instead of petrol-air mixture, only air is sucked from the atmosphere during the suction stroke. In a diesel engine, there is no need for a spark plug. Diesel engines are also called compression ignition engines. Dr Rudolf Diesel who invented the compression ignition engine was born in 1858.

**1. Suction Stroke** During this stroke, the inlet valve is kept opened and the exhaust valve is closed. The piston comes down to the bottom dead centre (BDC) from the top dead centre (TDC). Pressure in the cylinder will be slightly less than the atmospheric pressure. Air is drawn inside the engine cylinder through the inlet valve.

**2. Compression Stroke** In this stroke, both the inlet and exhaust valves are kept closed. The air is compressed when the piston moves up to TDC. The compression ratio varies from 15–20 for diesel engines. Due to high compression, higher temperature is obtained in the range of 550°C. At this juncture, diesel oil at a high pressure is injected inside the hot compressed air in an atomised form. Due to the special shape of the combustion chamber, the mixing of fuel and air takes place very rapidly and the mixture is ignited due to the high compression temperature, without any help of a spark plug. So, the diesel engine is also called compression ignition engine. Due to combustion, very high pressure is produced.

**3. Working or Power Stroke** During this stroke, both valves are kept closed. The piston is pushed down from TDC to BDC. The force above the piston is transmitted to the crank shaft through the connecting rod and crank mechanism. Excess energy due to the combustion is stored in the flywheel which helps the operation of three idle strokes.

**4. Exhaust Stroke** During this stroke, the exhaust valve is kept opened and the inlet valve is kept closed. The piston moves up from BDC to TDC. The waste gases are sent through the exhaust valve and the cycle is repeated.

During these four strokes, the crank shaft will make two revolutions. The thermal efficiency of a 4-stroke engine is higher compared to a 2-stroke cycle engine. Most of the cars operate on a 4-stroke cycle.

## 11.6 DIFFERENCES BETWEEN PETROL ENGINES AND DIESEL ENGINES

[May 2012, Regulation 2008]

Table 11.1

	<i>Petrol engines</i>	<i>Diesel engines</i>
1.	Compression ratio is 7–10.	Compression ratio is 15–20.
2.	Petrol–air mixture is compressed.	Only air is compressed.
3.	Compression pressure is 15–20 bar.	Compression pressure is 30–40 bar.
4.	Compression temperature is about 400°C.	Compression temperature is above 550°C.
5.	Peak pressure is in the range of 50–70 bar.	Peak pressure is high in the range of 80–100 bar.

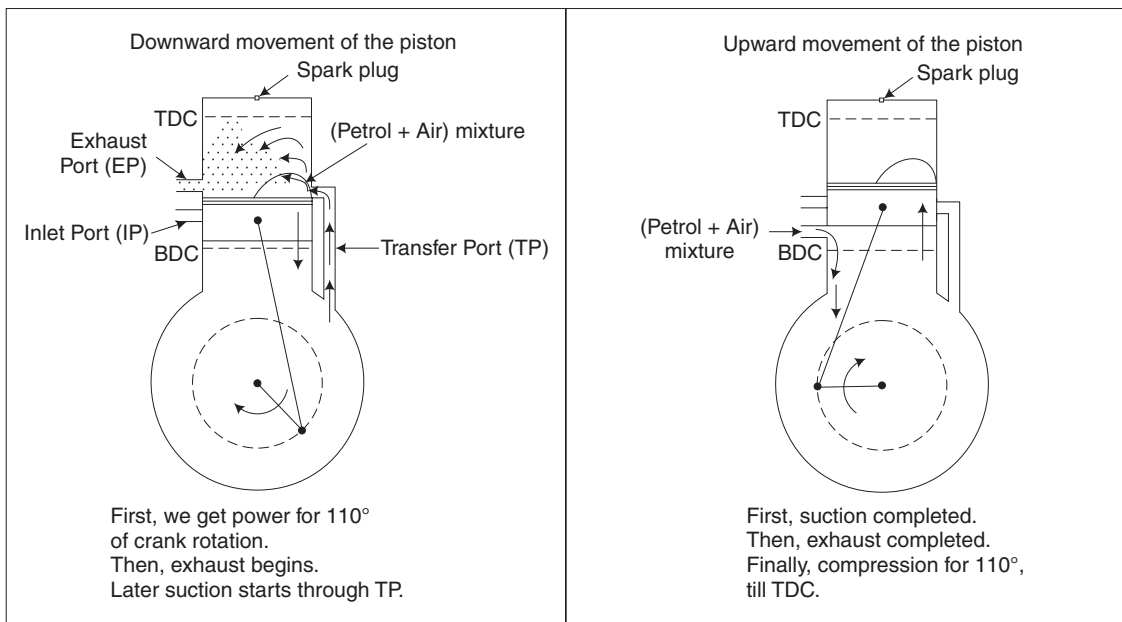
6.	Thermal efficiency is low in range of 20–25% due to low compression ratio.	Thermal efficiency is high in the range of 25–30% due to high compression ratio.
7.	Spark plug is necessary to ignite the fuel-air mixture.	No need for spark plug as compression temperature is enough to ignite.
8.	Due to low peak pressure, thickness of parts is less.	Due to high pressure, thickness of parts is more.
9.	Weight of the engine is less.	Weight of the engine is more.
10.	Cost of the engine is less.	Cost of the engine is more.
11.	Operating cost per km is high due to high cost of petrol and low thermal efficiency.	Operating cost per km is considerably low due to low cost of diesel and higher thermal efficiency.
12.	Due to better mixing of air and petrol, air–fuel ratio is less. For normal operation, it is in the range of 17–18.	Due to poor mixing of air and fuel, air–fuel ratio is very high (25–40). Mixing becomes poor due to lack of time.

### 11.7 WORKING OF A TWO-STROKE PETROL ENGINE

[Nov 2012; May 2014, Regulation 2008]

In a two-stroke petrol engine, the cylinder is provided with the inlet port, the transfer port and the exhaust port.

These ports are opened and closed by the movement of the piston itself. The exhaust port as shown in Fig. 11.4 (a), is located slightly above the transfer port.

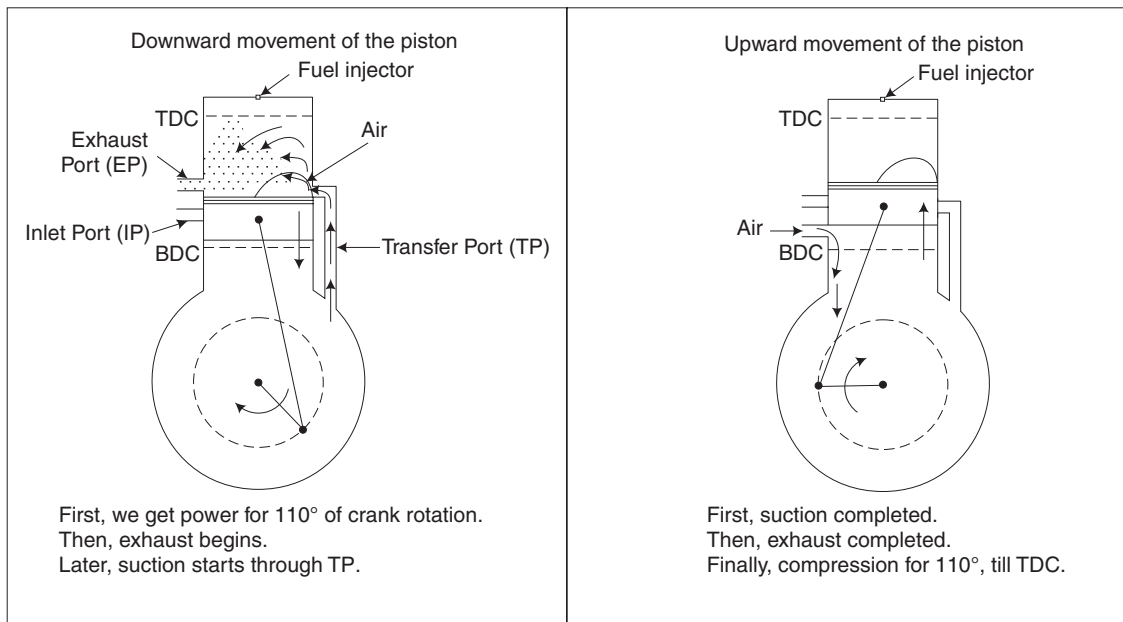


(a)

**Fig. 11.4(a)** 2-stroke cycle petrol engine

Let us study the condition when the piston is at TDC. In this position, only the inlet port is kept opened and the other two ports are closed. The mixture of air and petrol is drawn into the crank case due to the vacuum produced by the previous upward movement of the piston. Also, the mixture of air and petrol above the piston is compressed. The compression ratio for a petrol engine varies from 7-10.

When the spark occurs, the combustion starts and the piston is pushed down due to the pressure created. During its downward motion, the inlet port also is closed due to which the mixture will get compressed inside the crank case. At about  $70^\circ$  from BDC the exhaust port is opened (Note: the beginning of exhaust) and the gases are sent to the atmosphere. At about  $60^\circ$  from BDC, the transfer port is opened (Note: the beginning of 'transfer of charge' into the cylinder) and due to which the mixture from the crank case enters the cylinder. Refer to the port timing diagram in Fig. 11.4(b)



(b)

**Fig. 11.4(b)** 2-stroke cycle diesel engine

Because of the special shape of the piston crown, the mixture is deflected up and is prevented from going out directly through the exhaust port. Also, the deflected mixture helps in pushing the exhaust gases out, thus scavenging is improved. Thus, during the downward motion of the piston, we get the operation of power, exhaust and suction or intake.

When the piston is pushed up by the flywheel, the following sequence of operations take place:

1. Closing of transfer port
2. Closing of exhaust port
3. Opening of inlet port

After closing of the exhaust port, the mixture of air and petrol gets compressed and the cycle is repeated.

### 11.8 WORKING OF A TWO-STROKE DIESEL ENGINE

It is very similar to the operation of a 2-stroke petrol engine (refer to the earlier sketches). In a 2-stroke diesel engine, the cylinder is provided with the inlet port, the transfer port and the exhaust port.

The ports are opened and closed by the movement of the piston itself. The exhaust port is slightly above the transfer port.

Let us study the condition when the piston is at TDC. In this position, only the inlet port is kept open and other two ports are closed. The air from the atmosphere is drawn into the crank case due to the vacuum produced by the upward movement of the piston. The air above the piston is compressed to a high temperature. The compression ratio for a diesel engine varies from 15–20. Diesel oil at a high pressure is injected in an atomised form into the hot compressed air.

Combustion starts and the piston is pushed down due to the pressure created. During this downward motion, the inlet port also is closed due to which the air will get compressed inside the crank case. At about  $70^\circ$  from BDC the exhaust port is opened and the gases are sent to the atmosphere. At about  $60^\circ$  from BDC, the transfer port is opened due to which the air from the crank case enters the cylinder.

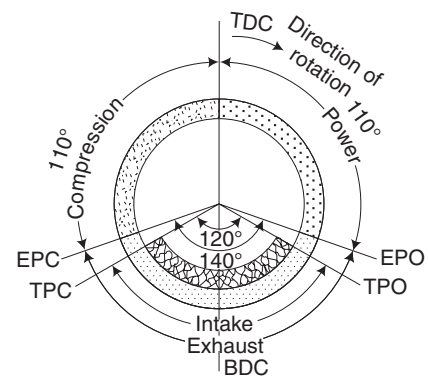
Because of the special shape of the piston crown, the air is deflected and is prevented from going out directly through the exhaust port. Also, the deflected air helps in pushing the exhaust gases out. Thus, during the downward motion of the piston, the operation power, exhaust and suction is obtained.

When the piston is pushed up by the flywheel, the following sequence of operations take place.

1. Closing of transfer port
2. Closing of exhaust port
3. Opening of inlet port

After closing of the exhaust port, the air gets compressed and the cycle is repeated.

[May 2014, Regulation 2008]



**Fig. 11.4(c)** Port-timing diagram

## 11.9 DIFFERENCES BETWEEN A 4-STROKE AND A 2-STROKE ENGINE

[May 2009, 2013; May 2014; Apr 2015, Regulation 2008; Nov 2014, Regulation 2013]

The Table 11.2 can be read as the table of differences between the two types of engines and also as the merits and demerits of the two designs.

**Table 11.2** Differences between a 4-stroke and a 2-stroke engine

	<i>4-stroke engine</i>	<i>2-stroke engine</i>
1.	One working stroke for every 4 strokes or 2 revolutions.	One working stroke for every 2 strokes or one revolution.
2.	As the number of cycles is less, power output is less for the same cylinder size.	Power is more for the same cylinder size. More suitable for a diesel power plant.
3.	The weight of the engine is more for the same output power.	The weight of the engine is considerably less. So, it is more suitable for a marine engine.
4.	Operating temperature is less. So, less consumption of lubricating oil.	Operating temperature is more. So, more consumption of lubricating oil. Special piston cooling is necessary in large engines.
5.	Variation of torque is more. So, heavier flywheel is necessary.	Smaller flywheel is enough as the torque is more uniform.
6.	Noise is less.	Noise is more due to frequent exhaust.
7.	Higher thermal efficiency.	Thermal efficiency is less due to possible wastage of fuel-air mixture through the exhaust port.
8.	Due to a valve mechanism, the design and manufacture of the engine is difficult and cost is more.	Easier in design and the manufacturing cost is less.
9.	Straight piston is used.	Deflector piston is used.

## 11.10 FUEL SYSTEM IN A PETROL ENGINE

[May 2013, Regulation 2008]

The fuel system in a petrol engine consists of the following: a fuel tank, fuel gauge, a fuel filter, a fuel pump and a carburetter.

For cars, the capacity of the fuel tank is about 50 litres. To indicate the amount of fuel in the tank, a fuel gauge is provided which operates by means of a float mechanism. As the fuel has to pass through a fine hole in the carburetter, the petrol should be first filtered. As the petrol tank is at a lower level than the carburetter, the petrol is pumped by a small -capacity diaphragm pump by a cam mechanism driven by the crankshaft.

### 11.10.1 Carburetter

This can be considered as the heart of a petrol engine. Extensive development work has been carried out throughout the world in improving the working of the carburetter.

#### *Functions of the Carburetter*

1. To evaporate the liquid petrol and mix with the correct amount of air and supply the petrol-air mixture in the desired ratio at all speeds and loads. For normal speed,

the desirable air–fuel ratio is in the range of 17–18. At higher speeds, we need a richer mixture and for starting, we need extra rich mixture with air–fuel ratio in the range of 10–12.

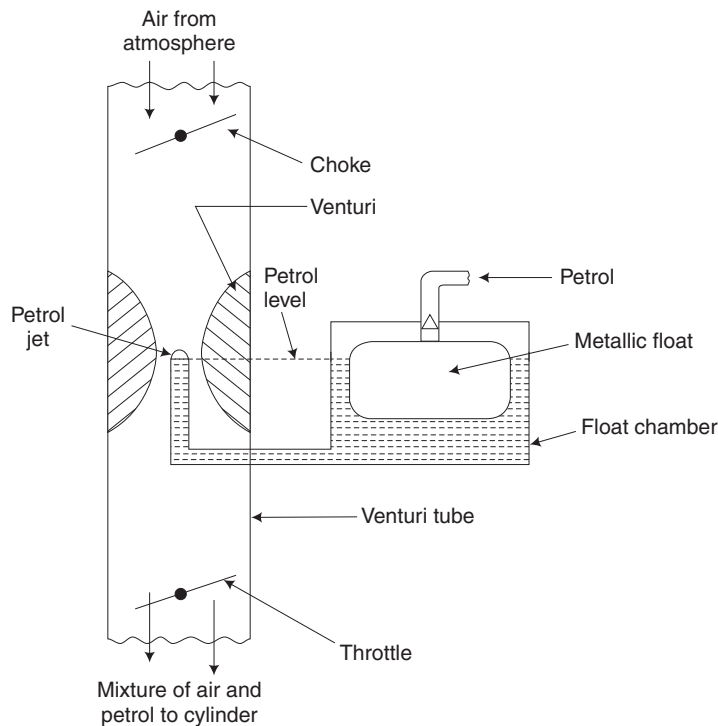
2. Provision to vary the speed of the engine by regulating the amount of fuel–air mixture entering the cylinder (throttle).
3. Provision for easy starting (choke).
4. In modern carburetters, provision has been made for altitude correction, climatic correction, quick acceleration, etc., by providing multijets and various other means.

Dealing with modern carburetters is beyond the scope of this textbook. Only the working of a single-jet carburetter is dealt with, giving the basic principle of working.

### **Working of a Simple or Single-Jet Carburetter**

A simple carburetter consists of the following parts:

1. A float chamber
2. A venturi tube
3. Single petrol jet
4. Choke
5. Throttle



**Fig. 11.5** *Single-jet carburetter*

The *float chamber* as shown in Fig. 11.5, maintains a constant level of petrol. The tip of the petrol jet is slightly above the level of petrol and it is located in the reduced area of the venturi tube.

During the suction stroke of the engine, vacuum is produced in the cylinder due to which air rushes through the *venturi tube*. When the air passes through the centre of the venturi tube, the velocity of air increases and the pressure decreases due to the reduction in area. Due to the vacuum produced, the petrol is automatically sucked through the *petrol jet*. It is sprayed through the fine hole at the end of the jet. The vapourised petrol mixes with air and the mixture goes to the engine cylinder through the throttle.

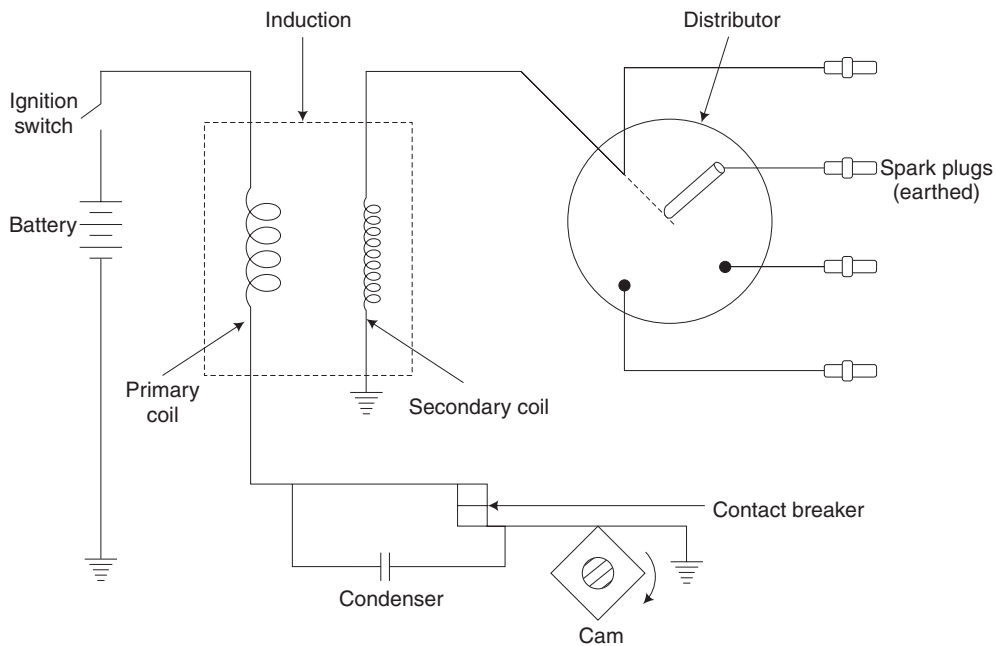
The speed of the engine can be changed by controlling the amount of mixture, by means of the throttle, connected to the accelerator. For starting, an extra rich mixture is required and this can be obtained by partly closing the choke, thereby reducing the amount of air.

### Defects of a Single-Jet Carburetter

1. It tends to supply richer mixture at high speed and weaker mixture at slow speed.
2. Starting is comparatively difficult.
3. There is no correction for altitude.
4. There is no correction for climatic variation.

## 11.11 BATTERY OR COIL-IGNITION SYSTEM

Figure 11.6(a) shows the coil-ignition circuit for a four-cylinder petrol engine. The battery provides 12 V supply to the primary circuit. It is kept charged by a dynamo driven by the engine. The ignition switch is in the form of a key, operated by the driver.



**Fig. 11.6(a)** Ignition system

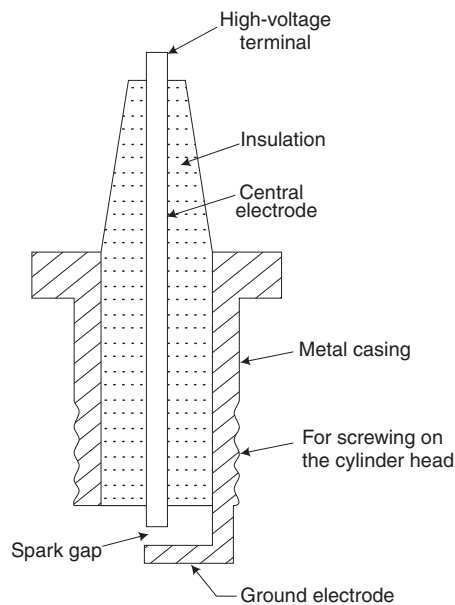
The induction coil consists of two coils, one primary and the other secondary. The primary coil consists of 200–300 turns of thick enamelled copper wire and the secondary coil consists of 15000–20000 turns of thin enamelled copper wire. The contact breaker is a mechanical device for breaking and making the primary circuit. It is operated by a cam, as shown in the sketch. An electrical condenser is provided to avoid sparking at contact-breaker points.

When the contact breaker is closed, the current flowing in the primary circuit produces a magnetic field in the induction coil. When this magnetic field is made to collapse suddenly by the contact breaker, a high voltage is induced in the secondary coil. The high voltage is supplied to the correct spark plugs at the correct time by means of the distributor and produces the spark.

### 11.11.1 Spark Plug

[May 2012, Regulation 2008]

In a petrol engine, as the temperature at the end of compression is not enough to ignite the petrol–air mixture, a spark is provided at the right time by means of a spark plug. A simple sketch of the spark plug is given in Fig. 11.6(b).



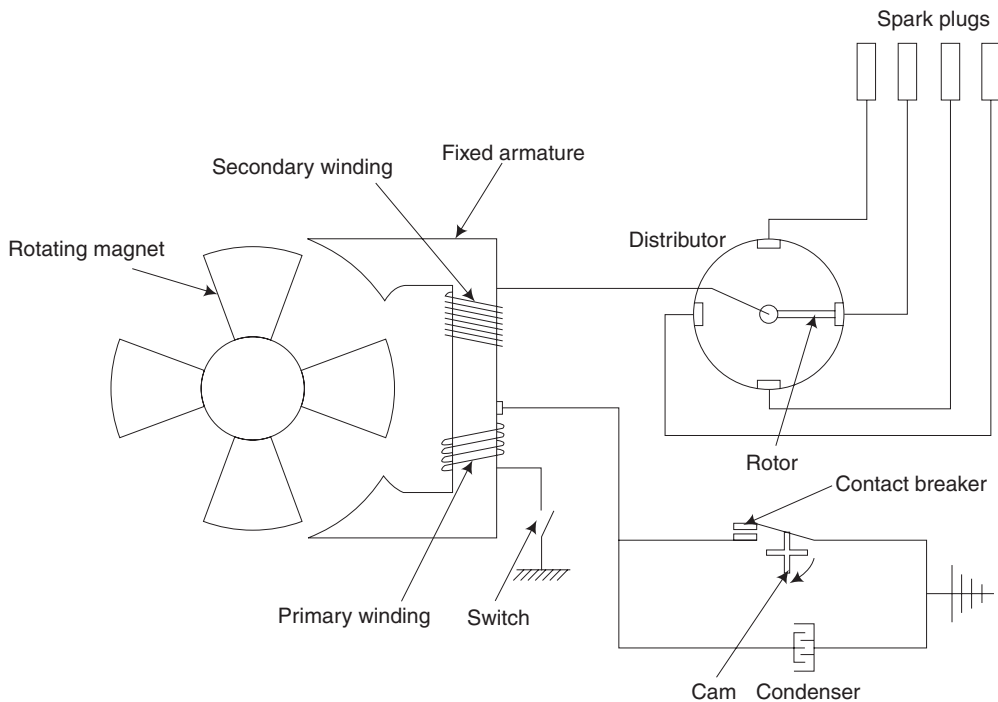
**Fig. 11.6 (b)** *Spark plug*

The spark plug is screwed into the cylinder head. It consists of a central electrode surrounded by an insulator. When a high voltage is applied to the central electrode, a spark is produced in the spark gap when the high voltage tries to jump across the gap. The spark gap varies from 0.6–1 mm. The gap should be maintained correctly and it should be free from carbon dust or oil. Periodically, the tip should be cleaned.



### 11.11.2 Magneto-Ignition system

Figure 11.6(c) shows the sketch of a magneto-ignition system. This is similar to the coil-ignition system, except that the battery is replaced by a magneto. The magneto consists of a rotating magnet and a fixed armature. It is like an electric generator. The armature consists of primary and secondary windings. The magneto is located on the outer rim of the flywheel and revolves around the stationary coil.



**Fig. 11.6 (c)** *Magneto-ignition system*

The primary winding, ignition switch, condenser and the contact breaker form the primary circuit and the secondary winding distributor and spark plugs form the secondary circuit.

When the contact breaker is closed by the rotating cam, current flows in the primary circuit. This will produce magnetic field in the primary circuit. When the contact breaker is opened by the rotating cam, very high voltage is produced in the secondary coil due to sudden collapse of magnetic field. The high voltage is distributed to the spark plugs through the distributor.

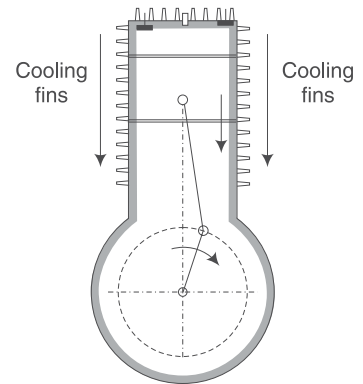
## 11.12 COOLING SYSTEM IN IC ENGINES

[Nov 2010; May 2014, Regulation 2008]

Due to the combustion of fuel inside the cylinder, very high temperature is produced. Any metal tends to become weak at high temperature. If the engine is not cooled, parts such as the cylinder, the cylinder head, the piston, the piston rings, and the valves

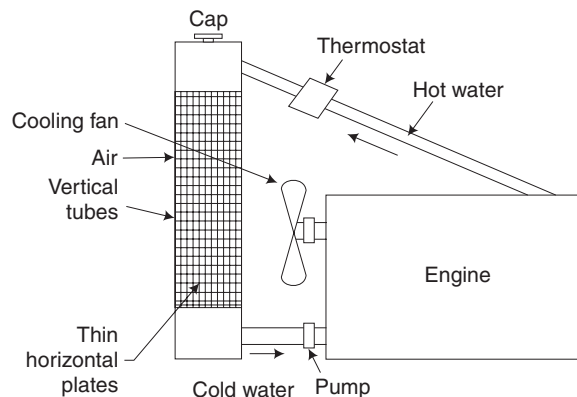
will get overheated resulting in the reduction of strength and possibility of distortion of components. Overheating may even cause seizure of the piston. Properties of the lubricating oil will change at high temperature and it may decompose resulting in carbon deposit in the cylinder and piston. So cooling becomes essential in IC engines. At the same time, overcooling should be avoided. At full load, about 30% of the heat liberated by the fuel is lost in cooling. Two types of cooling are usually adopted.

**1. Air Cooling** This system is adopted for motorcycles, scooters, aero engines and also in some cars. Cooling fins are provided in the cylinder and cylinder head as shown in Fig. 11.7. In large-sized engines, arrangement is made to circulate the air around the cooling fins. The amount of heat dissipated depends on the area of cooling fins, the amount of air circulated, the velocity of air and the temperature difference with the surroundings.



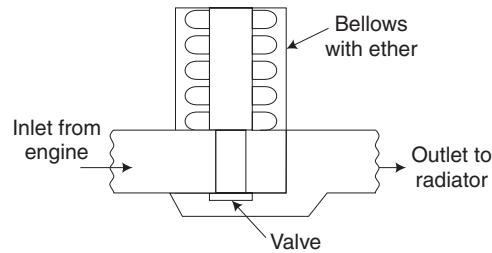
**Fig. 11.7** Air cooling

**2. Water Cooling** This system is commonly used in cars, buses and lorries. Water passages between the double walls of the cylinder and the cylinder heads are called the *water jackets*. Water is circulated through jackets by a pump driven by the crank shaft. When the circulating water becomes hot, it is cooled in a radiator as shown in Fig. 11.8(a). Water used in the radiator should be free from salt and other impurities. Otherwise, the deposit will block the water tubes. It is desirable to add some anticorrosion solution in the water. The radiator should be periodically cleaned. In cold places, antifreeze solution should also be added in the water.



**Fig. 11.8(a)** Radiator cooling system

It is desirable to fit a thermostat in the upper hose connection in the radiator. During the warm-up period of the engine, the thermostat valve is closed. When the normal operating



**Fig. 11.8(b)** *Thermostat*

temperature of about  $60^{\circ}\text{C}$  is reached in the water, the thermostat valve opens due to the evaporation of ether in the bellows and permits the water to circulate through the radiator. The sketch of a thermostat is given Fig. 11.8(b).

### 11.12.1 Difference between Air Cooling and Water Cooling

**Table 11.3**

	<i>Air cooling</i>	<i>Water cooling</i>
1.	Design is simple	Design is comparatively complex
2.	Weight of the engine is less	Weight is more due to water in the radiator
3.	Cost of engine is less	Cost is more
4.	No problem of leakage or freezing of water	Both the problems exist
5.	More noise	Less noise as water dampens the vibration
6.	Maintenance is very easy	Maintenance is comparatively difficult due to the possibility of leakage of water, blockage of tubes in the radiator, pump failure etc
7.	Control of the temperature is difficult	It can be easily controlled by fitting a thermostat

### 11.13 LUBRICATION SYSTEM

[Nov 2012, Regulation 2008]

The following are the main functions of a lubrication system:

1. To reduce friction between the rubbing parts and reduce the wear and tear.
2. To reduce the temperature of the working parts.
3. To reduce the noise.
4. To keep the rubbing parts clean by removing worn-out materials and carbon dust.
5. To act as a sealing between the cylinder and piston and to prevent the leakage of gases.

#### **Parts to be Lubricated**

1. Reciprocating parts like piston.
2. Rotating parts like crank shaft.

3. Oscillating parts like connecting rod.

### Types of Lubricants

1. Liquids like mineral oil, vegetable oil, etc.
2. Semiliquids like grease.
3. Solid lubricants like graphite powder, either alone or mixed with oil or grease.

### 11.13.1 Requirements of a Good Lubricating Oil

1. High viscosity index (if the change of viscosity with temperature is less, the oil is rated to have a high viscosity index).
2. High flash point and low pour-point temperatures.
3. Non-corrosive.
4. Good detergent quality to keep the rubbing surfaces clean.
5. High film strength (ability to maintain a thin film of oil even at high load).
6. The quality of lubricating oil is improved by adding different types of additives such as the viscosity index improvers, the corrosion inhibitors, the detergent additives, and the film strength additives.

Lubricating oils are graded in SAE number according to the viscosity. For example, the viscosity of oil SAE 40 is higher than that of oil SAE 30. For different engines or machines, we should use the oil of correct grade as specified by the manufacturer. In IC engines, oil should be filled in the crank case to the specified level, as indicated by the dip stick.

### 11.13.2 Types of Lubrication

[Nov 2012; May 2014, Regulation 2008]

The different types of lubrication are the following:

1. Splash lubrication
2. Pressure lubrication
3. Petroil method

The *splash lubrication* system as in Fig. 11.9(a) is suitable only for small capacity engines. During the working of the engine, the scoop dips into the lubricating oil in the crank case and throws the oil to the piston, cylinder and other parts.

In the *pressure lubricating system*, the oil in the crank case is filtered by an oil filter. The filtered oil enters the oil pump and its pressure is raised to the desired value and distributed to the different parts, shown in Fig. 11.9(b). For the lubrication of the crank pin and the piston pin, small holes are provided in the crank shaft and the crank pin through which oil flows.

For lubrication of light spark ignition engines, lubricating oil is directly mixed with petrol and this is known as the *petroil method*.

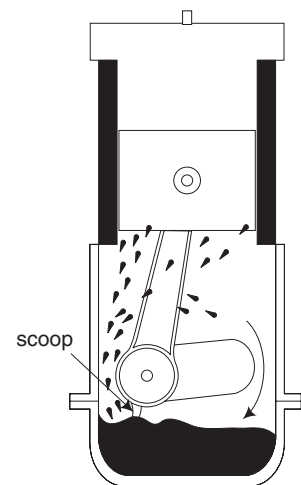
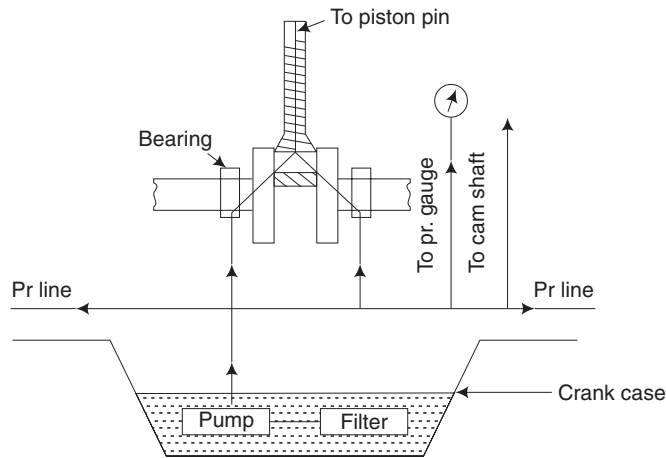


Fig. 11.9(a) *Splash lubrication*



**Fig. 11.9(b)** *Pressure lubrication*

## 11.14 FUEL SYSTEM FOR DIESEL ENGINES

The system consists of the following:

1. Fuel tank with a float mechanism connected to the fuel gauge
2. Fuel filter
3. Fuel pump
4. Fuel injector or atomiser

### **Function of the Fuel System**

[May 2013, Regulation 2008]

1. It should deliver the required amount of fuel at the correct time for different loads and speeds.
2. Injection of fuel should be at the desired rate to control the pressure rise during combustion.
3. Atomisation of the fuel should be to the desired degree. If the atomisation is too high, the penetration of fuel becomes poor.
4. It should help in the rapid mixing of fuel and air.
5. Beginning and closing of injection should be sharp.

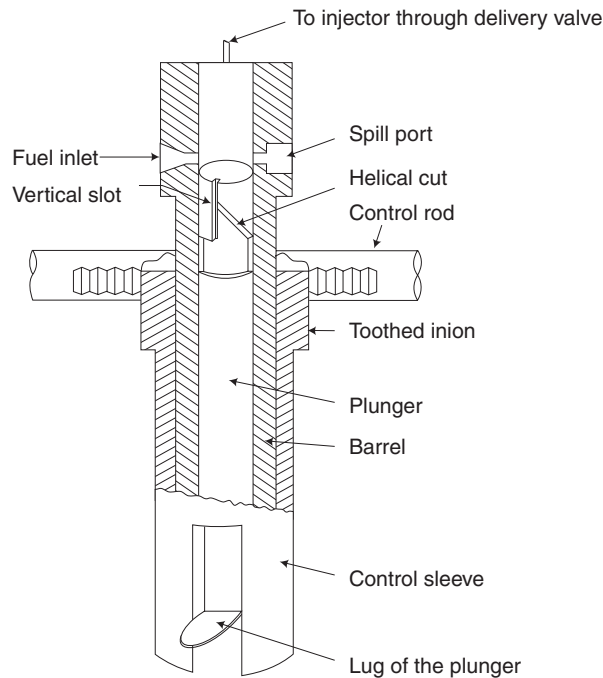
### 11.14.1 Fuel Pump

The pump produces the high pressure necessary for injection, in the order of 100–400 bar, depending upon the engine size and the type of combustion chamber used. It also controls the amount of fuel pumped for different loads and speeds.

It consists of a plunger working in a barrel. The plunger is moved up against the action of a spring by means of a cam. Fuel comes to the barrel through the inlet line. During the upward movement of the plunger, when the inlet and spill ports are closed, pressure is

developed in the fuel and is sent to the injector through a delivery valve under the action of a spring (not shown in the sketch).

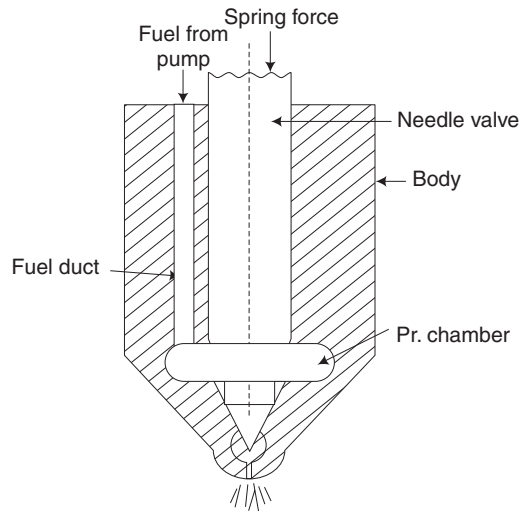
By the action of a cam, the plunger has a constant stroke. But, the effective stroke of the plunger can be varied and thereby the quantity of fuel can be changed by slightly rotating the plunger through an angle by means of a control rod, connected to the accelerator. This is made possible by a vertical hole or slot in the plunger and also by a special helical cut in the plunger as shown in Fig. 11.10.



**Fig. 11.10** *Fuel pump for a diesel engine*

### 11.14.2 Fuel Injector

The lower portion of the fuel injector is described in Fig. 11.11. The needle valve is kept in the seat by a helical spring. The tension of the spring can be adjusted manually by a nut on the top of the injector (not shown in the sketch) to vary the pressure of injection. Fuel under pressure from the fuel pump enters the pressure chamber through the fuel duct. Because of high pressure, the needle valve is lifted up against the spring tension. When the valve is lifted, the fuel rushes out through the fine hole (single hole or multiholes) in an atomised form and rapidly mixes with the compressed air which will be turbulent inside the combustion chamber.



**Fig. 11.11** *Single-hole injector*

## 11.15 PETROL INJECTION

As modern carburetters used in petrol engines have certain drawbacks, there is a shift towards petrol injection systems. In petrol injection, timing is by no means critical and the fuel may be injected during the suction stroke in the inlet manifold at low pressures. The petrol-injection systems are mainly grouped into the following two groups:

**1. Continuous Injection System** In this system, fuel is sprayed at a low pressure continuously into the air supply. The air-throttle opening governs the amount of fuel injected into the cylinder. The advantages of this system are listed below:

1. Atomisation of fuel is very efficient.
2. Supplies uniform mixture to all the cylinders.
3. Volumetric efficiency increases due to the cooling of compressed charge by the evaporative effect of the fuel.
4. One injector and one fuel injection pump are enough for this system.

**2. Timed Injection System** The timed injection system is similar to the system used in high-speed diesel engines. The timed injection system is further grouped into the following two groups.

- (i) **Multiple-Plunger Jerk Pump System** A pump having a separate plunger for each cylinder is employed in this system. At a definite time and over a definite period of the induction stroke, the fuel is delivered into each cylinder. The injection pressure usually ranges from 100 bar to 300 bar.
- (ii) **Low-Pressure Single-Pump and Distributor System** In this system, a single plunger pump delivers fuel at low pressure to the rotating distributor, which supplies the fuel to each cylinder. The injection pressure usually ranges from 3.5 bar to 7 bar.

### ***Disadvantages of Petrol Injection***

1. Due to high precision and complex component assemblies, initial cost of the petrol-injection system is much higher than conventional carburetion system.
2. As there are many moving parts, there are increased service problems. The noise level is also more.
3. Weight and size of this system will be more than that of a carburetter.

Due to the above disadvantages, today it is not popular in cars and motorcycles. However, it is being used in some racing cars and aero engines.

### **11.16 DIFFERENCE BETWEEN DIESEL INJECTION AND PETROL INJECTION**

Table 11.4 shows the difference between diesel and petrol injection.

**Table 11.4**

<i>Diesel injection</i>	<i>Petrol injection</i>
1. Fuel is directly injected into the cylinder.	Fuel is injected in the inlet manifold.
2. Injecting pressure is high.	Injecting pressure is low.
3. The moment at which fuel injection commences has a very important influence.	Timing is by no means critical and the fuel may be injected during the suction stroke.
4. Fuel is injected at the end of the compression stroke.	Fuel is injected during the induction stroke.

### ***Short-Answer Questions***

1. *Answer the following questions:*
  - (a) How are the IC engines classified based on the fuel used?
  - (b) What is the function of scraper rings provided on the piston?
  - (c) What is the function of flywheel?
  - (d) List the strokes that constitute a four-stroke engine.
  - (e) Define scavenging in a 2-stroke engine.
  - (f) List the ports used in a 2-stroke engine.
  - (g) Briefly list out the important functions of the carburetter.
  - (h) What is the function of a spark plug?
  - (i) What is the function of a fuel injector in diesel engines?
  - (j) Why cooling is necessary in an IC engine?
  - (k) What are the different types of cooling in IC engine?
  - (l) What is the use of thermostat valve in the case of a radiator cooling system?
  - (m) Why should the IC engines be lubricated?
  - (n) What are the different methods of lubrication?
  - (o) Explain what is meant by viscosity index of lubricating oil.



- (p) What is the Petroil method of lubrication?
- (q) Explain the specific function of fuel pump and injector in a diesel engine.
- (r) List the requirements of a good lubricating oil.
- (s) Petrol injection is not popular. Why?
- (t) State the differences between petrol injection and diesel injection.
2. *Fill up the blanks with suitable word/words:*
- (a) A gasket is provided between the cylinder and the cylinder head to \_\_\_\_\_ .
- (b) Common gasket materials are \_\_\_\_\_ and \_\_\_\_\_ in IC engine.
- (c) A connecting rod converts \_\_\_\_\_ motion of the piston into the \_\_\_\_\_ of the crankshaft.
- (d) In the suction stroke, the pressure in the cylinder will be \_\_\_\_\_ than the atmospheric pressure.
- (e) The thermal efficiency of the four-stroke engine is more compared to a two-stroke engine because \_\_\_\_\_ .
3. *Choose the correct answer from the following:*
- (a) In a four-stroke cycle engine, the operations are in sequence.
- (i) suction, expansion, compression and exhaust
- (ii) suction, exhaust, compression and expansion
- (iii) suction, compression, exhaust and expansion
- (iv) none of the above
- (b) In a four-stroke cycle engine, the number of revolutions of the crankshaft for completion of working cycle is
- (i) one                      (ii) two                      (iii) three                      (iv) four
- (c) In a two-stroke cycle engine, the number of revolutions of the crankshaft for completion of working cycle is
- (i) one                      (ii) two                      (iii) three                      (iv) four
- (d) At the same speed, the number of power strokes given by a two-stroke cycle engine as compared to a four-stroke cycle engine is
- (i) half                      (ii) same                      (iii) double                      (iv) four times
- (e) The petrol engine works on
- (i) Otto cycle      (ii) Joule cycle      (iii) Diesel cycle      (iv) Carnot cycle.
- (f) The suction in a petrol engine contains
- (i) fuel only                      (ii) mixture of air and fuel
- (iii) air only                      (iv) none of the above.
- (g) The term 'scavenging' is generally related with
- (i) two-stroke engines                      (ii) four-stroke engines
- (iii) steam engines                      (iv) air-cooled engine

- 
- (h) The function of the distributor in a coil ignition system of an IC engine is to
- (i) distribute spark
  - (ii) distribute current
  - (iii) distribute power
  - (iv) time the spark
- (i) The function of the carburettor is to supply
- (i) air and petrol
  - (ii) air and diesel
  - (iii) only petrol
  - (iv) only diesel
- (j) In a petrol engine, air–fuel ratio is controlled by the
- (i) distributor
  - (ii) carburettor
  - (iii) governor
  - (iv) injector
- (k) A fuel injector is used for a
- (i) 5:1 engine
  - (ii) CI engine
  - (iii) steam engine
  - (iv) steam turbine
- (l) In a diesel engine, fuel is injected
- (i) at the beginning of the suction stroke
  - (ii) at the beginning of the compression stroke
  - (iii) nearly at the end of the compression stroke
  - (iv) none of the above
- (m) The number of valves in a 2-stroke motorcycle engine is
- (i) two
  - (ii) three
  - (iii) four
  - (iv) none of the above
4. *State whether the following statements are true or false:*
- (a) The function of the upper rings in IC engine is to provide gas-tight sealing and to prevent the leakage of burnt gases.
  - (b) Cams control the opening and closing of valves in four-stroke engines.
  - (c) During the four strokes, the crankshaft makes two-revolutions.
  - (d) One complete revolution of the crankshaft produces one power stroke in two-stroke engines.
  - (e) Thermal efficiency of a diesel engine is higher than the petrol engine due to high compression ratio.
  - (f) The speed of the engine is controlled by the throttle valve.
  - (g) Air cooling is used in buses and lorries.
  - (h) The voltage supplied to the battery ignition system is 12 V.
  - (i) Petrol lubrication is used in heavy-duty spark ignition engines.
5. *Distinguish between the following:*
- (a) SI engine and CI engine
  - (b) Four-stroke engine and two-stroke engine
  - (c) Water cooling and air cooling
  - (d) Splash lubrication and petrol lubrication

## **UNIT-5**

# **REFRIGERATION AND AIR-CONDITIONING SYSTEM**



# Chapter 12

## REFRIGERATION AND AIR CONDITIONING

### *PART A - REFRIGERATION*

#### **12.1 INTRODUCTION**

[May 2012, Regulation 2013; Apr 2015, Regulation 2013]

Refrigeration is defined as 'the science of providing and maintaining the temperature below that of the surrounding atmosphere.' For this to be achieved, heat has to be removed from the source at a lower temperature and rejected to the atmosphere at a higher temperature. It is well known that heat can spontaneously flow from higher temperature to a lower temperature. However, for heat to flow in the reverse direction, the second law of thermodynamics stipulates that external work/energy should be supplied.

Normally, the refrigeration systems are classified on the basis of the capacity of the unit. The domestic refrigerators are classified based on the volume (number of litres), while the air conditioning systems are classified by their load (tons of refrigeration). In case of the deep freezers, the systems are identified with volume and lowest temperatures that can be obtained. The systems can also be classified according to the mode of working as refrigerator or heat pump.

#### **12.2 UNIT OF REFRIGERATION**

[Nov 2012; May 2014, 2015, Regulation 2008]

The unit of refrigeration is called 'Ton of Refrigeration' (TR) which is defined as the quantity of heat to be removed to produce one ton of ice at 0°C, within 24 hours when the initial condition of water is also at 0°C. In the SI units, 1 TR is equivalent to 210 kJ/min or 3.5 kW. Air conditioners are also specified by the same unit TR.

#### **12.3 PERFORMANCE OF A REFRIGERATOR**

[May 2012, Regulation 2008; Nov 2014, Regulation 2013]

When a refrigerator is removing  $Q$  amount of heat (it is also called cooling load) consuming  $W$  amount of work, then the performance of the refrigerator is determined by the ratio  $Q/W$ , which is called the coefficient of performance (COP).

$$\text{COP} = Q/W \text{ when } Q \text{ and } W \text{ are in the same units.}$$

One should not confuse it with the term 'efficiency' which is always less than 1. For example, in a heat engine, heat is converted into mechanical or electrical work. During the conversion, some heat energy is lost due to which the efficiency will be obviously less than 1. But, in the case of a refrigerator, the input energy ( $W$ ) helps only in transfer of heat. Here, COP is always more than 1. Higher the value of COP, performance of the refrigerator can also be treated as higher or better.

## 12.4 APPLICATIONS OF REFRIGERATION

1. In water coolers, to supply cold water for drinking.
2. To manufacture ice.
3. For preservation of food, vegetables, milk, ice cream, etc., in houses, hotels, ships, etc.
4. For preservation of perishables like fish, mutton, chicken, etc.
5. Preservation of medicines, blood, tissues, etc., in hospitals.
6. Preservation of dead bodies in mortuaries in hospitals.
7. Different types of industrial applications.
8. For air conditioning in houses, offices, theatres, hospitals, computer centres, etc.

## 12.5 REFRIGERANTS

A refrigerant is the working fluid in a refrigerator. It is capable of absorbing heat at a lower temperature and rejecting the heat at a higher temperature, in the form of sensible heat or latent heat or both.

## 12.6 DESIRABLE PROPERTIES OF REFRIGERANTS

[May 2009, 2015, Regulation 2008; Apr 2015, Regulation 2013]

1. Low boiling point, low freezing point, high latent heat of evaporation.
2. Low specific heat and low viscosity.
3. It should be easy to liquefy.
4. Odourless and no hazardous effect on leakage.
5. Chemical stability.
6. Nonflammable.
7. Low cost.

## 12.7 TYPES OF REFRIGERANTS

[Nov 2009, 2010, Regulation 2008]

Chemical refrigerants are assigned an  $R$  number which is determined systematically according to molecular structure. Common refrigerants are frequently referred to as Freon (a registered trademark of DuPont).

1. **Freon-12** It is dichlorodifluoromethane ( $\text{CCl}_2\text{F}_2$ ). This was the most commonly used in domestic refrigerators, water coolers and freezers. It is classified as a refrigerant, which is not eco-friendly.

2. **R-134a** It is Tetrafluoroethane ( $C_2H_2F_4$ ). It is now being used as a replacement for R-12 CFC refrigerant in the area of centrifugal, rotary screw, scroll and reciprocating compressors. It is safe for normal handling as it is non-toxic, non-flammable and non-corrosive.
3. **Freon-22** It is monochlorodifluoromethane ( $CHClF_2$ ) and it has a boiling point of  $-41^\circ C$ . It is mostly used in air conditioners.
4. **Ammonia** It is R717 ( $NH_3$ ). It is mostly used in absorption system. It has a boiling point of  $-33.3^\circ C$ .
5. Other refrigerants include carbon dioxide ( $CO_2$ ), sulphur dioxide ( $SO_2$ ) and methyl chloride ( $CH_3Cl$ ). Carbon dioxide is mainly used in marine refrigerators.

## 12.8 METHODS OF REFRIGERATION

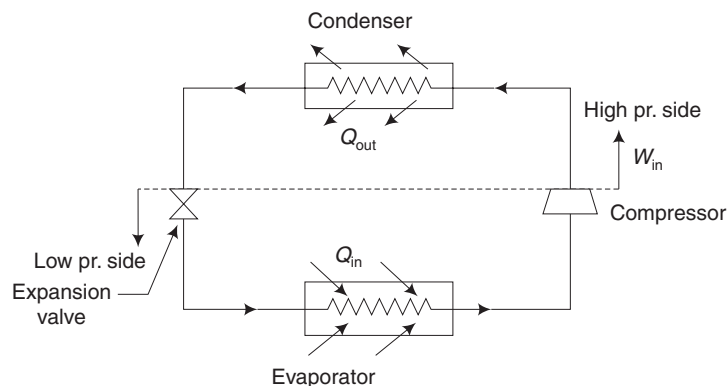
In this section, the following two methods to produce refrigeration effect are described.

1. Vapour-compression refrigeration
2. Vapour-absorption refrigeration

### 12.8.1 Vapour-Compression Refrigeration Systems

[Nov 2009, 2012; May 2012; Nov 2013; Apr 2015, Regulation 2008;  
Nov 2014; May 2015, Regulation 2013]

The vapour-compression refrigeration system is widely used in refrigeration applications like refrigerator, water cooler, air conditioner and cold storage. The schematic diagram of this system is shown in Fig. 12.1.



**Fig. 12.1** Vapour-compression refrigeration

The refrigerant enters the evaporator at a lower pressure and temperature. Here, it absorbs its latent heat of vaporisation from the substances kept around the evaporator, thus cooling them. The chillness thus produced at the evaporator is known as refrigeration effect. The refrigerant usually comes out of the evaporator with its phase changed to dry saturated or slightly superheated state.

Now, it enters the compressor which is the heart of the system. The refrigerant vapour is compressed to a higher pressure and temperature as superheated vapour in the compressor. For this activity, power is supplied to the motor connected to the compressor and it constitutes the major running cost of the system.

The compressed refrigerant vapour is led into the condenser. Generally, atmospheric air is blown over the condenser using a fan and it carries away the latent heat from the refrigerant vapour. Water cooled condensers are also available. Therefore, the refrigerant vapour is condensed into high pressure liquid.

The liquid refrigerant enters the expansion device which can be a long spirally wound capillary tube in small refrigerators. Here, the refrigerant is throttled to low pressure, low temperature wet vapour, thus completing the cycle. Two other expansion devices are automatic expansion valve and thermostatic expansion valve.

Almost, all the refrigeration systems shall be provided with an accumulator to store the refrigerant in the event of any shutdown, for maintenance.

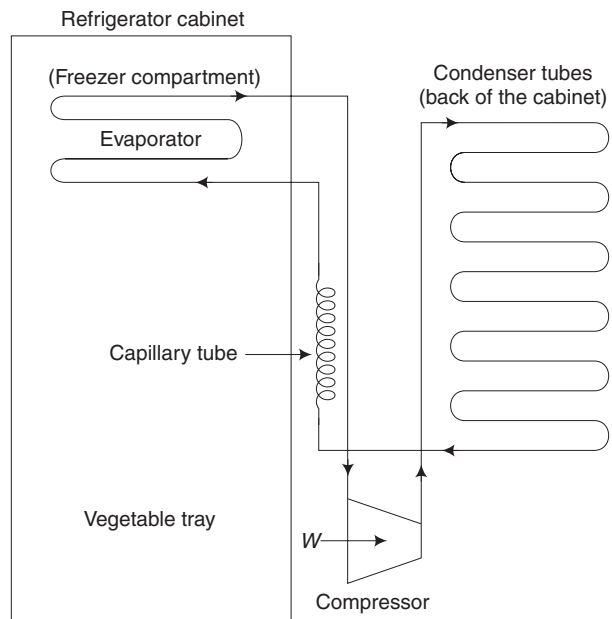
If a low temperature, in the order of  $-50^{\circ}\text{C}$  is needed, cascade refrigeration systems can be used. Cascade refrigeration system comprises of two individual vapour compression refrigeration systems in series. The two refrigeration systems shall have two different refrigerants. In the cascade refrigerator, evaporator of the first unit shall act as a condenser of the second refrigeration system.

### 12.8.2 Domestic Refrigeration System

[Nov 2012; Apr 2015, Regulation 2008; Nov 2014, Regulation 2013]

The layout of a domestic refrigerator is given in Fig. 12.2. It belongs to the vapour compression type. The evaporator which is the coldest part is located in the freezer compartment. A separate door is provided for the freezer where we can store ice, ice-cream and perishable items like mutton, chicken, fish etc. Just below the freezer, usually a chiller tray is provided. Further below and behind the main door, there are several compartments with progressive higher temperatures. The bottom-most compartment is for vegetables where a very low temperature is not necessary.

The condenser tubes are kept on the back of the refrigerator cabinet. The refrigerant vapour is condensed with the help of surrounding air which rises



**Fig. 12.2** Domestic refrigerator layout



above by natural convection. In the no-frost refrigerator, the evaporator is located outside the freezer compartment. The cold air is made to flow into the freezer compartment by a fan.

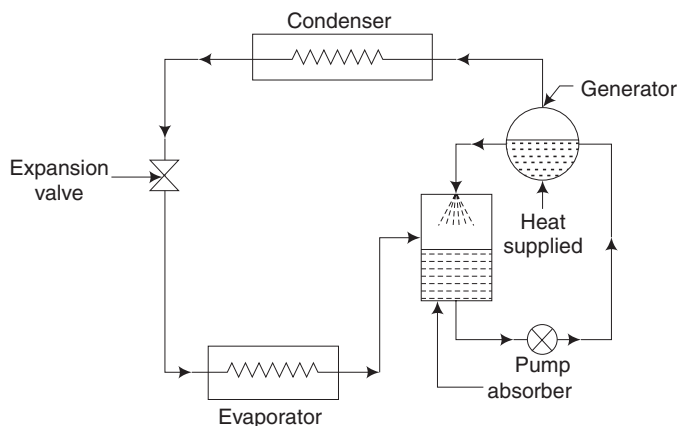
### 12.8.3 Vapour-Absorption Refrigeration System

[May 2009; Nov 2010; 2012; May 2014, Regulation 2008]

The vapour-absorption refrigeration system is similar to the vapour-compression refrigeration system except for the manner in which the low-pressure vapour coming out of the evaporator is compressed. This system eliminates the compressor, yet produces the compressor effect by the combined effects provided by an absorber, a pump and a generator. The pump consumes comparatively lesser amount of electric power and the generator can be operated by heat energy obtained from the burning of any low-cost fuel or any heat source including solar energy.

The schematic diagram of a simple vapour absorption system is shown in Fig. 12.3. The refrigerant used is ammonia and the absorber is water. Ammonia vapour coming out from the evaporator at low pressure is absorbed by water available in the absorber tank resulting in a strong ammonia solution. The pump pumps the solution, thereby increasing its pressure and sends the high-pressure solution into the generator. In the generator, the solution is heated by external heat supply. Now, high-pressure ammonia gas is generated which enters the condenser. The weak ammonia solution available in the generator contains more amount of water. It goes back to the absorber tank where it absorbs the incoming ammonia vapour and becomes once again a strong solution. The processes taking place in the condenser, expansion device and the evaporator are similar to those discussed under Section 12.8.1.

The absorber used in the vapour-absorption refrigeration system should have high affinity for the refrigerant, remain in the liquid phase under the operating conditions and should possess high boiling point, low specific heat and good chemical stability.



**Fig. 12.3** Vapour-absorption refrigerator

## 12.9 COMPARISON BETWEEN VAPOUR-COMPRESSION AND VAPOUR-ABSORPTION SYSTEM

	<i>Vapour Compression</i>	<i>Vapour Absorption</i>
1.	Smaller in size	Very large in size for the same capacity
2.	Refrigerant is Freon-12	Ammonia
3.	Electric power is needed to run the compression	Heat input can be supplied by a heater, or by exhaust steam or even by solar energy
4.	COP is higher	Lower
5.	Wear and tear will be more	Less
6.	System produces noise	Silent in operation
7.	Maintenance cost is high	Low

## 12.10 SOLAR REFRIGERATOR/AIR-CONDITIONING SYSTEM

This system belongs to vapour-absorption type. Instead of heating the solution in the generator by an electric heater or by supplying the heat by burning any fuel, the solution can be directly heated in a solar collector.

It is rather surprising to note that solar heat can be used to produce cooling effect in the refrigerator or to cool a room by a solar air conditioner. The author has made use of a Japanese solar air conditioner in the laboratory at Bahrain University during 1980–1984. As the crude oil in the Gulf countries is expected to be exhausted in about 75 years, solar refrigeration/air conditioning system will become popular in the future.

## PART B - AIR CONDITIONING

### 12.11 INTRODUCTION

[Apr 2015, Regulation 2013]

Air conditioning involves controlling and maintaining the desired temperature, humidity, velocity and direction of flow of air in a closed space. Also, filtering and cleaning of air is carried out by the air-conditioning system.

Air-conditioning does not always mean cooling the air. During winter, in many places across the world, the temperature becomes extremely low. Hence, in such areas, air conditioning means heating and humidification. The author has experienced up to  $-27^{\circ}\text{C}$  in USA. during the period of his stay from 1956–58 at Purdue University. Similarly, when we are flying at an altitude of about 10,000 metres, the temperature surrounding the aircraft will be several degrees below  $0^{\circ}\text{C}$ , due to which the passengers' area should be warmed up.

### 12.12 APPLICATIONS OF AIR CONDITIONING

1. Air conditioning of houses, hotels, theatres, etc.
2. Hospitals, operation theatres and intensive care units are air conditioned.

3. For comfort of passengers in cars, buses, trains, ships and aeroplanes.
4. Air conditioning becomes very essential in many industries like textiles, food, printing, machine tools, etc.

### 12.13 IMPORTANT TERMINOLOGY IN AIR CONDITIONING [May 2014, Regulation 2008]

<i>Dry air</i>	Air without water vapour or moisture.
<i>Moist air</i>	It is a mixture of dry air and water vapour.
<i>Dry-bulb temperature</i>	Actual temperature of a gas, measured by a standard mercury thermometer
<i>Wet bulb temperature</i>	The temperature measured by a mercury thermometer, when the bulb is covered by a moistened cloth
<i>Saturated air</i>	A mixture of dry air along with the maximum possible water vapour, at dry-bulb temperature
<i>Relative humidity</i>	The ratio of the mass of water vapour in a given volume of air at the given temperature to the mass of water vapour present in the same volume under the same temperature of air when it is fully saturated

### 12.14 REQUIREMENTS OF COMFORT AIR CONDITIONING

[May 2009, 2015, Regulation 2008; Nov 2014; Apr 2015, Regulation 2013]

Due to the natural phenomenon of body heat disposal by evaporation of moisture from the human body and inflow of moisture from other sources, the humidity inside a room increases. The increased humidity causes difficulty in disposing of body heat. Also, the room temperature rises due to the heat dissipated from the human body and heat gains from light source and any other equipment. When the room temperature is high, it causes human discomfort.

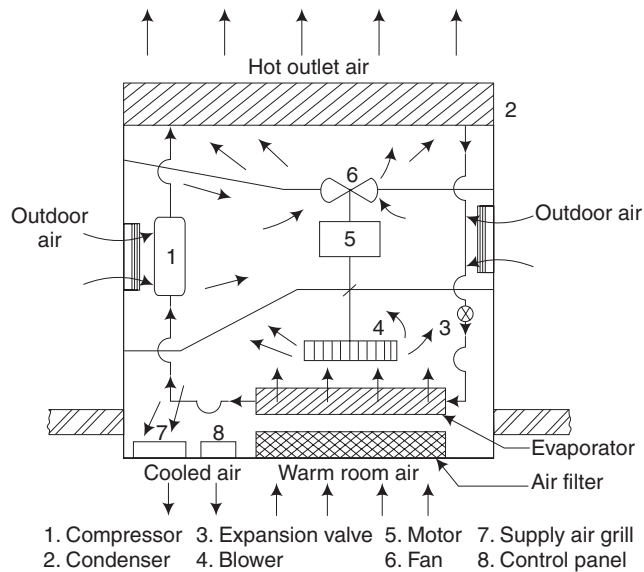
It has been found that for human comfort we need a dry-bulb temperature of 20°C and relative humidity of 60 per cent in the room. Any air-conditioning system should primarily be able to achieve the above said conditions inside the room.

Under normal living conditions, a person inhales about 0.65 m<sup>3</sup> of oxygen and exhales about 0.2 m<sup>3</sup> of carbon dioxide in an hour. If the CO<sub>2</sub> level in the room increases above two per cent, it will cause human discomfort. Hence, the air conditioner should supply enough quantity of fresh air called ventilation air to meet the oxygen requirements and maintain the CO<sub>2</sub> level within limits. Also, the conditioned air should have a velocity in the range of 8 m/min to 14 m/min and be properly distributed inside the room for a feeling of comfort. Further requirements of comfort air conditioning demand that the conditioned air be free from dust, bacteria, odour and toxic gases.

### 12.15 WINDOW AIR CONDITIONER

[May 2012, 2013, 2014, Regulation 2008; Apr 2015, Regulation 2013]

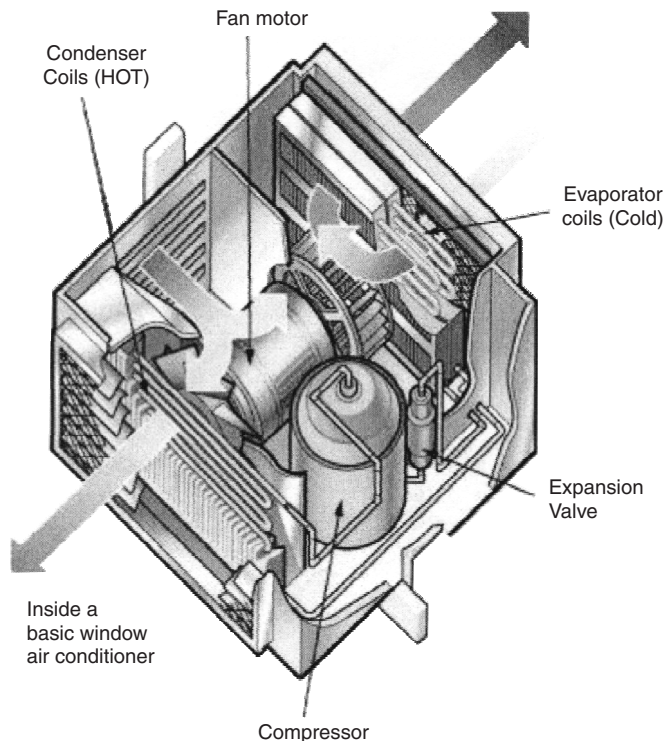
A simple air-conditioning system without ducts, assembled inside a casing suitable for installation on windows or wall openings is called a window air conditioner. The unit consists of a vapour-compression refrigeration system, a double shaft motor, a blower, a fan, air filter, supply air grill, return air grill, fresh air damper, drain tray and a control panel as shown in Fig. 12.4.



**Fig. 12.4(a)** Layout of a window AC

The blower sucks the warm air from the room through the air filter and the evaporator or cooling coil of the refrigeration system. Then, it delivers the cooled and dehumidified air back into the room through the supply air grill. The moisture condensing out when the inlet air is passed over the evaporator coil is drained out. The operation of the refrigeration system is the same as discussed in Section 12.8.1. The supply air grill has adjustable louvers or deflectors for changing the direction of air upwards or downwards or horizontally. Mechanised louvers are available in some window air conditioners which continuously change the direction of air flow to ensure uniform distribution of conditioned air inside the room. The conditioned air sent into the room mixes with the room air and decreases the temperature and humidity levels in the room and thereby maintains human comfort inside the room. Fresh air is admitted through the adjustable damper for the purpose of ventilation.

Window air conditioners usually operate on 230 V, single phase ac supply and are available in cooling capacities ranging from 0.5 TR to 3 TR. Their installation is simple and



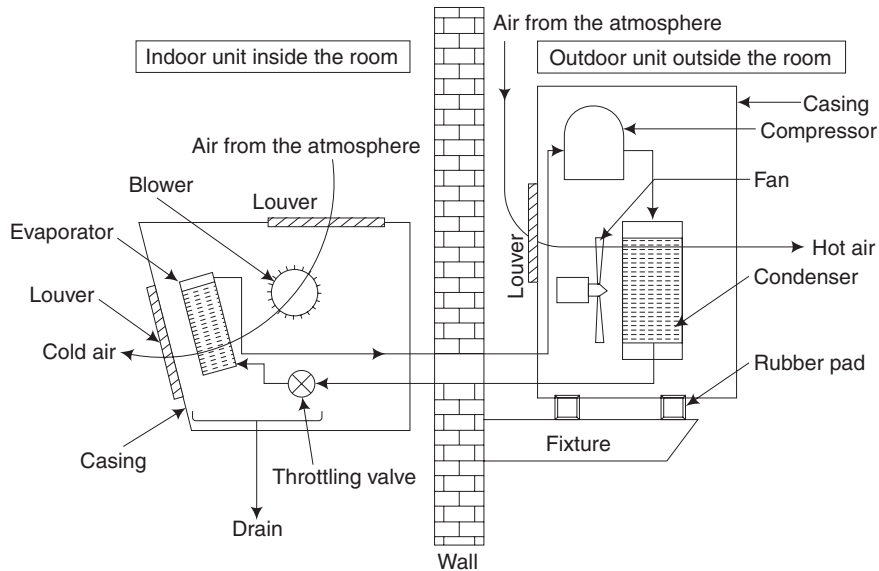
**Fig. 12.4(b)** Pictorial view of a window AC

does not require any plumbing work. However, they are not suitable for large halls and applications where the heat and moisture loads are very high. In such cases, central air-conditioning systems are preferred. Pictorial view of a window air conditioner is given in Fig. 12.4(b).

### 12.16 SPLIT AIR-CONDITIONER

[May 2014, Regulation 2008]

An air conditioner has four major components, namely, the compressor, condenser throttling device and evaporator. In a window air conditioner, all these four major components are placed inside a single cabinet, with a small partition. In the case of a split air conditioner, the components are placed in two cabinets, namely, the indoor unit and outdoor unit as in Fig. 12.5. As the name implies, the indoor unit is to be placed inside the conditioned room while the outdoor unit is to be fixed outside the room. The indoor and the outdoor units are fixed with the help of suitable fixtures or hooks and they are connected with the help of tubes in which high pressure liquid and low pressure vapour would pass through a hole in the wall.



**Fig. 12.5** Split air conditioner

The main components of the indoor unit are the blower, evaporator, throttling valve and drainage system. The high-pressure liquid refrigerant from the outdoor unit is allowed to flow through the throttling valve to obtain low-pressure vapour refrigerant. The low-pressure wet vapour refrigerant is then allowed to pass through the evaporator. As the blower blows air over the evaporator, low pressure refrigerant obtained from the throttling valve is evaporated, to produce chillness in the surrounding of the evaporator. Air inlet and outlet louvers are placed at suitable locations to enable free cold-air flow.

The main components of the outdoor unit are the fan, condenser and compressor. The low-pressure vapour refrigerant from the evaporator of the indoor unit is allowed to flow through the compressor to obtain high pressure and high-temperature refrigerant. The high pressure and temperature vapour is then allowed to pass through the condenser. As the fan blows air over the condenser, high-pressure vapour condenses to form high-pressure liquid refrigerant. Air inlet and outlet louvers are placed at suitable locations to enable free air flow. Rubber pads are used to mount the outdoor unit, as the working of compressor will produce vibration.

### 12.17 CENTRAL AIR CONDITIONING

The central air-conditioning system is adopted for large buildings, star hotels, hospitals, cinema theatres, etc. This system is used only for heavy loads of about 20 tons or more. Various components of the central air-conditioning system are not assembled at the factory. Instead, they are all assembled at site in a control room from where conditioned

air is distributed to the required places through duct work. The duct work should be carefully designed, fabricated and erected.

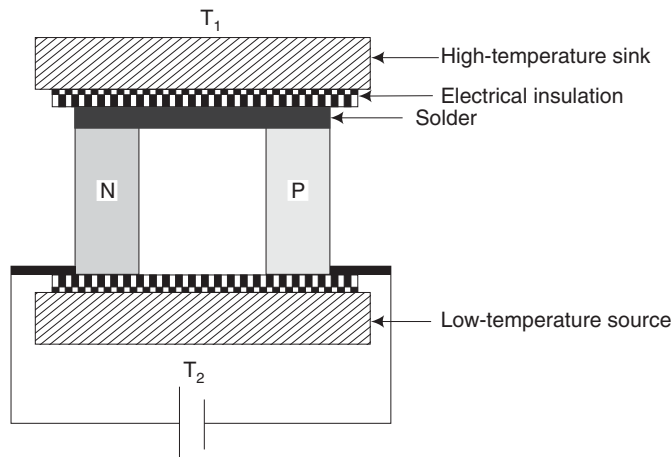
**Table 12.1** Comparison of unitary and central air-conditioning system

	Unitary Type	Central
1.	The capital cost is high, per ton of refrigeration	Cost is low
2.	Factory assembled	Assembled at site
3.	Located in the space to be conditioned	Located away from the conditioned space
4.	Smaller capacity units	Large capacity unit of 20 tons or more
5.	No need for duct work	Extensive duct work is essential
6.	Failure in the system will affect one room only	Will affect all the rooms
7.	Installation charges are less	Much higher

### 12.18 THERMOELECTRIC COOLING

The difference between the conventional and thermoelectric cooling methods, is that a thermoelectric cooling system refrigerates without the use of mechanical devices and refrigerant. Its working is based on the *Peltier Effect*. Two dissimilar conductors replace both the liquid and vapour phases of a conventional system in a thermo electric cooling refrigeration system. The compressor is replaced by a dc power source, which pumps electrons from one semiconductor to another.

The schematic diagram of a pair of semiconductors with different characteristics, which form a thermoelectric cooling module, is shown in Fig. 12.5a. They are connected electrically in series and thermally in parallel so that two junctions are created.



**Fig. 12.6** Schematic diagram of thermoelectric cooling module

Semiconductor materials are of  $N$  and  $P$  type. They are named like this because either they have more electrons than necessary to complete a perfect molecular lattice structure ( $N$ -type) or do not have enough electrons to complete a lattice structure ( $P$ -type). The extra electrons in the  $N$ -type material and holes left in the  $P$ -type material are called *carriers* and they are agents that move the heat energy from the cold to the hot junction, leading to refrigerating effect. These coolers can operate in the range of  $+60^{\circ}\text{C}$  to  $-40^{\circ}\text{C}$ . Good thermoelectric semiconductor materials such as bismuth telluride are widely used in these cooling devices.

### 12.18.1 Advantages of Thermoelectric Cooling

1. As there are no moving components, there is no problem of wearouts.
2. As conventional refrigerants like freon (CFC), corrosive liquids and gases are not used, they are environmentally safe.
3. Silent and maintenance-free operation.
4. Compact designs.
5. A unit may be converted from cooling to heating mode by reversal of polarity of the input power.
6. Light in weight.

### 12.18.2 Disadvantages of Thermoelectric Cooling

1. Separate dc power source is required (low voltage-up to 12 V DC and low current-up to 5 A DC).
2. Suitable only for small units.
3. Poor performance and so not suitable for large installations.

### 12.18.3 Applications of Thermoelectric Cooling

The use of thermoelectric cooling may be widely found in the electronics industry and in many computer centres. The main aim is to provide local cooling for the electronics components for better performance. Industrial equipment like computer aided manufacturing machines makes use of these cooling devices for the control systems.

### Short-Answer Questions

1. Answer the following questions:
  - (a) Define refrigeration.
  - (b) How are the refrigerators and other cooling machines classified?
  - (c) Define ton of refrigeration.
  - (d) Define COP of refrigerator.
  - (e) State the desirable properties of refrigerants.
  - (f) State the requirements of conditioned air.



- (g) What are the four major parameters controlled by an air conditioner?
- (h) List the important terminologies used in air conditioning.
- (i) What are the normal capacities of window air conditioners?
- (j) How are the air-conditioners classified?
- (k) In a split air-conditioner, what are main components fitted in the indoor unit and outdoor unit.
- (l) List the advantages of thermoelectric cooling.
- (m) What are the limitations window air conditioner?
2. *Fill up the blanks with suitable word/words:*
- (a) In a central air-conditioning plant, \_\_\_\_\_ is used to distribute conditioned air.
- (b) COP of a refrigerator is always more than \_\_\_\_\_.
- (c) Vapour absorption refrigeration systems are said to be economical due to the reason \_\_\_\_\_.
3. *Choose the correct answer from the following:*
- (a) Refrigeration systems are used to preserve materials in the following applications:
- |               |                      |
|---------------|----------------------|
| (i) hospitals | (ii) offices         |
| (iii) homes   | (iv) all are correct |
- (b) In a domestic refrigerator the coldest part is the
- |                             |                   |
|-----------------------------|-------------------|
| (i) freezer compartment     | (ii) chiller tray |
| (iii) vegetable compartment | (iv) none         |
- (c) In a vapour absorption refrigeration system, which type of compressor is used:
- |                         |                      |
|-------------------------|----------------------|
| (i) hermetically sealed | (ii) single cylinder |
| (iii) multi-stage       | (iv) all are wrong   |
4. *State whether the following statements are true or false:*
- (a) R12 is the commonly used refrigerant.
- (b) Solar heat can be used to produce refrigeration effect.
- (c) Central air-conditioning systems are used small loads only.
- (d) A thermoelectric cooling module is uses AC current.

### Exercises

1. Draw the layout diagram of a typical domestic refrigerator and explain the working of its various components.
2. Describe with help of diagram, Vapour Compression Refrigeration system.
3. Draw the sketch of vapour absorption refrigeration system and list out the components and their functions.

4. Explain the operation of any one type of refrigeration system with the schematic line diagram.
5. Write short notes on Window and split air conditioners.

# SHORT QUESTIONS AND ANSWERS

## BOILERS

- How are boilers classified?*
  - According to flow of water and gases
    - Fire-tube boilers
    - Water-tube boilers
  - According to pressure
    - Low-pressure boilers
    - High-pressure boilers
- Mention the advantages of high-pressure boilers.*
  - Heat energy per kg of steam is increased at high pressure.
  - Rate of steam production is high.
  - Superheated steam can be produced.
- State some application of steam boilers.*

Steam is useful for running steam turbines in electrical power stations, ships and steam engines in railway locomotives. It is also useful for many industrial applications.
- What is the use of an economizer in a high-pressure boiler?*

An economizer extracts the heat from the hot flue gases going out of the boiler and heats the water that is fed to the boiler.
- What is the use of a superheater in a high-pressure boiler?*

A superheater is used to increase the temperature of the steam above its saturation temperature.
- What do you understand by forced circulation boiler?*

In this type of boiler, water is circulated by a pump driven by a motor, for example, Lamont boiler
- What is a manhole in a boiler?*

A manhole is an oval-shaped or a circular-type hole provided in the boiler shell for cleaning, inspection and repair of the boiler.

8. *What is grate in a boiler?*

A grate is one of the parts of a boiler over which solid fuel is burnt.

9. *Why is a damper provided in a steam boiler?*

A damper is provided in a steam boiler to control the draught and thus regulate the rate of generation of steam.

10. *At what pressure do modern high-pressure boilers produce steam*

Modern high pressure boilers produce steam at 200 bar.

11. *What do you mean by the capacity of a boiler?*

The amount of steam generated per hour is known as the capacity of a boiler.

12. *What is scaling? State its effect.*

The impurities that are left behind when water is transformed into steam, forming a thin layer are called scales.

13. *What is meant by boiler-trial?*

Conducting a trial test on an existing boiler to determine the efficiency and capacity of the boiler and also the performances is called a boiler-trial.

14. *What are the differences between boiler mountings and boiler accessories?*

S.No	Boiler Mountings	Boiler Accessories
(i)	They are used for the safe operation of the boiler.	They are used to increase the efficiency of the boiler.
(ii)	Boiler mountings must be provided with every boiler	Boiler accessories are only optional.
(iii)	Examples: Safety valves, pressure gauge, fusible plug etc.	Examples: Economiser, air preheater, superheater etc.

## STEAM POWER PLANT

1. *List the advantages of a steam power plant.*

(i) Initial cost is low compared to hydro power plant.

(ii) Installation time required for the plant is less than the hydro power plant.

(iii) The power production does not depend on nature's mercy.

(iv) The power plant can be located near the load centre. So, the transmission cost and transmission losses are considerably reduced.

2. *State the disadvantage of steam power plants.*

(i) Erection requires long time.

(ii) Less efficiency.

(iii) Transportation of fuel is a problem.

3. *Give the function of condenser in steam power plant.*

A condenser is used to condense the steam from the turbine and again feed it to the boiler. A condenser also reduces the back pressure in the turbine which increases the thermal efficiency of the power plant.



6. *What are the advantages of a gas-turbine power plant?*
  - (i) Any type fuel can be used in a gas-turbine power plant.
  - (ii) The gas turbine plants are subjected to less vibration.
  - (iii) The installation and maintenance costs are lesser than diesel plants.
7. *What are the disadvantages of a gas-turbine power plant?*
  - i. Major part of the work (66%) developed in the turbine is to drive the compressor. Hence the net output is reduced.
  - ii. The unit is operated at high temperature and pressure, hence special metals are required for manufacturing of gas turbines.
  - iii. Plant load efficiency is poor compared to a diesel plant.

### **DIESEL ENGINE POWER PLANT**

1. *What is a diesel power plant?*

A system of equipment in which the diesel engine is directly coupled to the generator and thus producing electrical power is called diesel power plant.
2. *Mention some of the essential components of a diesel power plant.*
  - (i) Diesel engine
  - (ii) Engine starting system
  - (iii) Fuel system
  - (iv) Air intake system
  - (v) Engine cooling system
  - (vi) Exhaust system
  - (vii) Engine lubrication system
3. *Which types of power plants are used as peak-load power plants? Why?*

Diesel and gas-turbine power plants are used as peak-load power plants. Because these plants are easy to operate. They respond quickly to load fluctuations. They have low capacity which is suitable for peak loads.
4. *What is the capacity range of the common diesel power plant?*

Capacity range : 2 to 50 MW
5. *What are the advantages of diesel power plant?*
  - (i) Plant layout is simple and it is smaller in size.
  - (ii) Diesel power plants are more efficient than steam power plants.
  - (iii) It has no standby losses.
  - (iv) It can be quickly started up and brought into service.
6. *List the disadvantages of diesel power plants.*
  - (i) Capacity of the plant is low.
  - (ii) The repair and maintenance costs are higher than steam plants.
  - (iii) Life of the diesel plants is low, when compared to steam plants.
  - (iv) Operation is very noisy.

**NUCLEAR POWER PLANT**

1. *What is a nuclear power plant?*

A system of equipments which converts the nuclear energy into electrical energy is called a nuclear power plant.

2. *Mention some main parts of a nuclear power plant.*

- (i) Reactor core
- (ii) Turbine
- (iii) Steam generator
- (iv) Coolant pump
- (v) Feed pump
- (vi) Condenser
- (vii) Electric generator

3. *What are the nuclear fuels used in the nuclear reactor?*

Uranium<sup>235</sup>, Uranium<sup>238</sup>, Plutonium

4. *What is the function of a moderator in a nuclear power plant?*

A moderator is used to slow down the fast moving electrons in a nuclear reactor which are produced during nuclear fission.

5. *Name the materials used as moderators.*

- (i) Heavy water (D<sub>2</sub>O)
- (ii) Graphite
- (iii) Beryllium

6. *What is the use of a radiation shield?*

Radiation shield is a concrete shield used to absorb the hazardous radiations like alpha, beta, gamma rays and neutrons which tend to come out of the reactor to the atmosphere.

7. *Name any two nuclear power plants in India.*

- (i) Kalpakkam nuclear power plant
- (ii) Tarapur nuclear power plant, the first one in India

8. *What are the advantage of nuclear power plants?*

- (i) Nuclear fuels have very high energy density.
- (ii) Fuel transportation, handling and storage are quite simple.
- (iii) Fuel consumption is very less.
- (iv) Space requirement of a nuclear power plant is less as compared to other conventional power plants of equal capacity.

9. *List the disadvantage of nuclear power plants.*

- (i) Initial and running costs are higher than steam and hydro power plants.
- (ii) Not suitable for varying conditions.
- (iii) Danger of nuclear explosion which can lead to disaster over very large areas crossing even natural borders.
- (iv) Disposal of radio active waste is a biggest problem in nuclear power plants.

## HYDROELECTRIC POWER PLANT

1. *What is a hydroelectric power plant?*

A system of equipment which converts the potential energy of water stored in a dam built across the river into electrical energy is called a hydroelectric power plant.

2. *Name the main parts of a hydroelectric power plant.*

- |                  |                    |
|------------------|--------------------|
| (i) Dam          | (ii) Penstock pipe |
| (iii) Surge tank | (iv) Water turbine |
| (v) Power house  |                    |

3. *What is the function of a hydraulic turbine?*

Hydraulic turbines are used to convert the potential energy of water into mechanical energy.

4. *Give example of turbines for low head, medium head and high head in hydroelectric power plants.*

Low head.....Kaplan turbine

Medium head.....Francis turbine

High head.....Pelton wheel

5. *How do you classify hydraulic turbines according to the type of energy at inlet?*

- |                     |                       |
|---------------------|-----------------------|
| (i) Impulse turbine | (ii) Reaction turbine |
|---------------------|-----------------------|

(i) **Impulse turbine** If, at the inlet of turbine, energy available is only kinetic energy, the turbine is known as impulse turbine. In this, all the potential energy of water is converted into kinetic energy in the nozzle before striking the turbine wheel buckets or blades.

(ii) **Reaction turbine** If at the inlet of the turbine, the water possesses both kinetic energy as well as potential energy, the turbine is known as reaction turbine.

All the pressure energy of water is not completely converted into kinetic energy at the inlet, as in the case of impulse turbine.

## PUMPS

1. *What is a pump?*

A pump is a hydraulic machine which converts mechanical energy into pressure energy.

2. *What do you mean by pumping?*

The process of lifting water or any liquid from lower level to higher level is known as pumping.

3. *Mention important uses of pumps.*

- |                                     |                           |
|-------------------------------------|---------------------------|
| (i) Power plants                    | (ii) IC engines           |
| (iii) Irrigation purposes           | (iv) Chemical industries. |
| (v) To pump water to overhead tanks |                           |



4. What is the function of non-return valve in reciprocating pump?

It allows the liquid to flow in one direction only.

5. Name the different type of casings for the impeller of a centrifugal pump.

(i) Volute casing (ii) Vortgex casing (iii) Diffuser casing

6. How do you classify pumps?

(i) Centrifugal pumps (rotodynamic pumps)

(ii) Reciprocating pumps (positive displacement pumps)

7. Explain the functions of spiral casing for a centrifugal pump.

In casing, area of flow of liquid increases gradually. The increase in area of flow decreases the velocity of flow. Consequently, the decrease in velocity increases the pressure of the liquid flowing through the casing.

8. Define the terms: reciprocating pumps, centrifugal pumps, priming.

**Reciprocating Pump** It converts the mechanical energy into pressure energy by sucking the liquid into a cylinder, in which piston is reciprocating. The piston exerting a thrust on the liquid, thereby increasing its pressure energy.

**Centrifugal Pump** It is a hydraulic machine with a rotating part called impeller. In this pump, mechanical energy is converted into pressure energy by means of centrifugal force acting on the liquid. The liquid enters the pump at the peripheral hub and leaves the casing radially.

**Priming:** Priming means removal of air from the pump casing and suction line. If an impeller is made to rotate in the presence of even a small air pocket in any position of the pump, only a negligible pressure would be produced. The result is that no liquid will be lifted by the pump.

9. How do you classify reciprocating pumps?

(i) According to the contact of liquid with one side or both side of the piston

(a) Single-acting reciprocating pump

(b) Double-acting reciprocating pump

(ii) According to the number of cylinders

(a) Single-cylinder reciprocating pump

(b) Double-cylinder reciprocating pump

10. Define the terms: suction head, delivery head, mechanical efficiency:

**Suction head** It is the vertical height of the centre line of the centrifugal pump above the liquid surface in the sump. It is denoted by  $H_s$ .

**Delivery head** It is the vertical distance between the centre of the pump and the liquid surface in the tank. It is denoted by  $H_d$ .

**Mechanical efficiency** It is the ratio of the power available at the impeller to the power at the shaft of the centrifugal pump.

11. List out the main components of a reciprocating pump.

- |                     |                        |
|---------------------|------------------------|
| (i) Cylinder        | (ii) Piston or Plunger |
| (iii) Suction valve | (iv) Delivery valve    |
| (v) Suction pipe    | (vi) Delivery pipe     |

## IC ENGINES

- What is an IC engine?*  
An IC engine is a device used for converting heat energy into mechanical energy by combustion of a fuel.
- What is meant by SI engine? Why is it called so?*  
A petrol engine is called spark ignition engine, because the combustion of fuel takes place by means of a spark produced by the spark plug.
- What is meant by CI engine? Why is it called so?*  
Diesel engine is called compression ignition engine, because the combustion of fuel takes place due to the high temperature produced by the compression of air.
- Mention the main components of a petrol engine.*  
Cylinder, cylinder head, piston, connecting rod, valves, spark plug, crank shaft, camshaft and flywheel.
- What is a four-stroke engine?*  
In a four-stroke engine, one power stroke is completed for every four strokes of the piston or during two revolutions of the crankshaft.
- What is the function of a carburettor?*

  - To evaporate petrol with fast moving air and mix with it in the correct proportion
  - To regulate the supply of air–fuel mixture entering into the engine cylinders
- What is the fundamental difference between two-stroke and four-stroke engine?*  
In four-stroke engine, one power stroke is obtained in two revolutions of crank shaft whereas in a two-stroke engine, one power stroke is obtained in each revolutions of crank shaft.
- Why is fuel injected in a CI engine?*  
The fuel used in CI engine (i.e., diesel) cannot be vapourised and hence injected in the form of fine spray.
- Mention the types of ignition system used in a petrol engine.*

  - Battery (or) coil-ignition system
  - Magnetoignition system
- State the function of choke in a petrol engine.*  
Choke is provided for easy starting of the engine. It allows rich mixture into the cylinder by reducing the amount of air present in the mixture, at the time of starting.

11. *What are types of cooling systems used in IC engine?*
  - (i) Air cooling
  - (ii) Water cooling.
12. *Define lubrication.*

Lubrication is the process of applying lubricant between the surfaces of contact of two moving parts.
13. *Mention some engine parts that require frequent lubrication.*
  - (i) Cylinder, piston and piston rings
  - (ii) Main bearings
  - (iii) Crank shaft
  - (iv) Valves
14. *Define compression ratio of an IC engine.*

It is the ratio of the volume when the piston is at the bottom dead centre to volume when the piston is at the top dead centre.

Compression ratio = Maximum cylinder volume / Minimum cylinder volume
15. *What is the function of the deflector in a two-stroke engines?*

In the two-stroke petrol engine, the exhaust gases are removed from the cylinder with the help of fresh compressed charge. This process of removing exhaust gases is called scavenging. A specific shape is given to the piston, called deflector. The deflector helps to prevent the loss of incoming charge and also helps for exhausting the waste gases effectively.
16. *What is meant by carburetion?*

In the SI engine, combustible petrol–air mixture is prepared outside the engine cylinder. The process of vaporizing the fuel (petrol) and mixing it with air outside the cylinder in the SI engine is known as carburetion.
17. *What is the function of the float, float chamber and needle valve assembly in a single jet carburetter?*

A metallic float is placed inside the float chamber. The level of petrol in the float chamber is maintained constant and slightly below the top at the petrol jet by the float and needle valve arrangement.
18. *State limitations of a single-jet carburetter.*
  - (i) It gives proper mixture at only one engine speed and load. Therefore, it is suitable only for engines running at constant speeds and loads.
  - (ii) Starting is difficult.
  - (iii) Automatic control of air–fuel ratio is not possible due to climatic changes.
19. *Name the three ports provided at the cylinder walls in a two-stroke engine.*
  - (i) Inlet port
  - (ii) Transfer port
  - (iii) Exhaust port
20. *Define the terms: stroke, top dead centre, Bottom dead centre, air–fuel ratio and thermal efficiency.*

Stroke is the linear distance through which the piston moves inside the cylinder during one stroke. In other words, stroke length is the distance between the extreme upper and lower positions of the piston. Numerically, the stroke length is equal to twice the crank radius.

**Top dead centre** Top dead centre (TDC) in the vertical engine is the extreme position of the piston on the top of the cylinder. In the case of horizontal engine, this position is known as Inner dead centre (IDC). At TOC (or) IDC, the crank angle is zero.

**Bottom dead centre** Bottom dead centre in vertical engine indicates the extreme position at the bottom of the cylinder. In the case of the horizontal engine, this position is known as outer dead centre (ODC) At BDC (or) ODC, the crank angle is  $180^\circ$

**Air-fuel ratio** It is expressed as ratio of the mass of air to the mass of the fuel.

**Thermal efficiency** It is the ratio of work output of the engine to the fuel energy supplied to the engine.

21. *Why are two stroke engines preferred for two-wheelers?*

Two-stroke petrol engines are used in mopeds, scooters and motor cycles; because they run at high speeds with moderate power outputs.

22. *What is the function of scraper rings provided on the piston?*

The function of the scraper rings is to scrap the used lubricating oil into the crank case.

23. *What is the function of flywheel?*

It is mounted on the crank shaft. The flywheel stores the excess energy during the power stroke of the engine and helps the movement of the piston during the remaining idle strokes.

24. *Why is cooling necessary in an IC engine?*

Due to the combustion of fuel inside the cylinder, very high temperature is produced. Any metal tends to become weak at high temperature. If the engine is not cooled, parts such as the cylinder head, the piston, the piston rings and the valves will get over heated resulting in reduction of strength and possibility of distortion of components. Overheating may even cause seizure of the piston.

## REFRIGERATION

1. *Define the terms: refrigeration, refrigerator and refrigerant.*

Refrigeration is the process of removing heat continuously from a body to reduce its temperature lower than that of its surrounding atmosphere it.

**Refrigerator** The equipment on which refrigeration process takes place.

**Refrigerant** Refrigerant is the working fluid in a refrigerator.

2. *What are the desired properties of an ideal refrigerant?*
  - (i) Low boiling point
  - (ii) Low freezing point
  - (iii) High latent and sensible heat of evaporation
  - (iv) High COP
  - (v) Low viscosity
  - (vi) Low specific volume
  - (vii) Non-explosive
3. *Name commonly used refrigerants.*
  - (i) Ammonia ( $\text{NH}_3$ )
  - (ii) Freon – 12
  - (iii) Freon – 22
  - (iv) Carbon dioxide ( $\text{CO}_2$ )
  - (v) Sulphur dioxide ( $\text{SO}_2$ )
4. *What do you understand by refrigerating effect (capacity of refrigerator)?*

It is defined as the rate at which the heat is removed from the space to be cooled in a cycle. It is expressed in kilojoules per second, kJ/S.
5. *What is the function of absorbent in a vapour refrigerator?*

Absorbent is a substance which absorbs large quantities of refrigerant vapour when cooled and converts it into liquid. When heated subsequently, it produces vapour. Water has this property and is used as the absorbent. Ammonia ( $\text{NH}_3$ ) is used as the refrigerant, as it easily dissolves in water and vaporizes when heated subsequently.
6. *What are the different applications of refrigeration?*
  - (i) For preserving food, fruits and drinks for a long duration
  - (ii) For preserving medicines and medical drugs
  - (iii) To manufacture ice in ice plants
  - (iv) Used for producing freezer food, ice creams, chemicals and other products.
7. *Define COP.*

COP is the ratio of heat extracted to work input.
8. *Mention the types of refrigerators.*
  - (i) Vapour-compression refrigerators
  - (ii) Vapour absorption refrigerators
9. *Name some essential components of a vapour-compression refrigeration system.*
  - (i) Compressor
  - (ii) Condenser
  - (iii) Expansion valve
  - (iv) Evaporator
10. *State the function of the compressor*

A compressor is used to compress the low-pressure vapour refrigerant
11. *Define ton of refrigeration (TR).*

One ton of refrigeration is defined as the quantity of heat removed or amount of refrigeration required to freeze one ton of water at  $0^\circ\text{C}$  in 24 hours.  
1 ton of refrigeration = 3.5 kJ/s.

12. Name some essential components of a vapour-absorption refrigeration system.

- |                      |                      |
|----------------------|----------------------|
| (i) Absorber         | (ii) Pump            |
| (iii) Heat exchanger | (iv) Generator       |
| (v) Condenser        | (vi) Expansion valve |
| (vii) Evaporator     |                      |

13. What is the use of a condenser in the refrigeration system?

A condenser is used to condense the refrigerant which is in the form of vapour and make them into liquid. The condenser is a coil of tubes, which are made of copper.

14. What is the use of throttle valve?

The throttle valve is used to reduce the pressure of refrigerant. It is also called expansion valve.

15. What is the use of an evaporator?

An evaporator is used to pick up the heat from the space to be cooled. This is kept in the place, which is to be cooled.

16. Differentiate vapour-compression and vapour-absorption system.

S.No	Vapour compression system	Vapour absorption syste
(i)	Energy supplied is 0.25 to 0.5 times of the refrigerating effect.	Energy supplied is about 1.5 times the refrigerating effect.
(ii)	It produces more noise and more wear and tear.	It is quiet.
(iii)	Refilling of refrigerant is easy.	Refilling of refrigerant is difficult.
(iv)	Mechanical energy is utilized.	Heat energy is utilized.

## AIR CONDITIONING

1. Define air conditioning.

Air conditioning is the process of conditioning the air according to the human comfort, irrespective of external conditions.

2. Mention the types of air-conditioning.

- |                              |                                  |
|------------------------------|----------------------------------|
| (i) Comfort air conditioning | (ii) Industrial air conditioning |
|------------------------------|----------------------------------|

3. What is psychrometry?

It is the branch of science dealing with the study of the properties of air and water vapour mixture.

4. Define dry-bulb temperature.

The temperature of air measured by the ordinary thermometer is called dry-bulb temperature.

5. Define wet-bulb temperature.

The temperature of air measured by the thermometer when the bulb is covered by a wet cloth is known as wet-bulb temperature.

6. *Define specific humidity or humidity ratio.*

It is defined as the mass of vapour present in unit mass of dry air.

Specific humidity = Mass of water vapour / mass of dry air

7. *What is meant by saturated air?*

When the mixture of air and water vapour at a given temperature contains the maximum amount of water vapour, then the air is called saturated air.

8. *Define relative humidity.*

It is the ratio of the mass of water vapour in a given volume of air at the given temperature to the mass of water vapour present in the same volume under the same temperature of air when it is fully saturated.

9. *What is dew-point temperature?*

The temperature at which water vapour in the air begins to condense is known as the dew point temperature.

10. *Why is a window air conditioner called so?*

As the name implies, all the components of the air conditioner, compressor, condenser, evaporator, motor running the fan and the blower, etc., are assembled inside a casing installed in the window of a room at the window sill level. Window air conditioner is designed to condition the air in a single room.

11. *Mention the disadvantages of a window air conditioner:*

- (i) Not suitable for large halls.
- (ii) the installation can be made only on an outside wall of the room.

12. *State the advantages of a window air conditioner.*

- (i) It is a self-contained single-package unit.
- (ii) Ducts are not required for air distribution.
- (iii) Installation is simple and plumbing is not required.





# MODEL QUESTION PAPER-1

## BE/BTech DEGREE EXAMINATION Basic Civil and Mechanical Engineering

### PART A (Questions)

1. What are the type of surveying?

Surveying may be primarily classified into following two types:

- (1) **Plane surveying:** The mean surface of the earth is considered as a plane.
- (2) **Geodetic surveying:** The curvature of the earth is taken into account.

According to the instruments used it is classified as follows:

- (1) Chain surveying
- (2) Compass surveying
- (3) Theodolite surveying
- (4) Plane Table surveying
- (5) Tacheometric surveying

2. Write any four types of cement.

Rapid hardening cement

Sulphate resisting cement

Low heat cement

Quick setting cement

Portland pozzolona cement

White cement

3. What is SBC—safe bearing capacity of soil.

Maximum load per unit area which the soil will resist safely without displacement.

$$\text{Safe Bearing Capacity} = \text{Ultimate Bearing Load} / \text{Factor of safety}$$

4. Write the relation between stress and strain and show the notations used.

When a material is loaded within the elastic limit, stress is directly proportional to strain.

or

$$\text{Stress} = \sigma$$

$$\text{Strain} = \varepsilon$$

$$\text{Young's Modulus} = E$$

$$\text{Stress/Strain} = \text{Constant} = \text{Young's modulus.}$$

$$\sigma / \varepsilon = E$$

5. Classify the power plants.  
6. Write the working principle of centrifugal pumps.  
7. What are the types of heat engines and define about any one type?  
8. Write down any two prime requirements of a boiler.  
9. What is capacity of refrigerator?  
10. Define air conditioning.

## PART – B

11. (a) (i) What are the principles of surveying?  
(ii) Explain with a sketch the rise and fall method of leveling.  
(b) (i) What are the qualities of stones?  
(ii) What is cement concrete and what are the tests carried out in cement concrete?
12. (a) What are the types of foundation? Write down the requirements of good foundation.  
(b) (i) Compare the brick masonry with stone masonry.  
(ii) Define stress and strain.
13. (a) Write in detail the working of thermal power plants and also give their advantages.
- (or)
13. (b) What are the advantages of nuclear power plants? Write down the applications of diesel power plants.

14. (a) Classify the I.C. Engines. With a neat sketch show the parts of I.C. engines.

(or)

14. (b) Explain with a sketch the various stages involved in the four stroke cycle diesel engine.

15. (a) State the principle of refrigeration. Write the properties of an ideal refrigerant.

(or)

15. (b). Classify the air-conditioning systems and explain them briefly.

# MODEL QUESTION PAPER-2

## BE/BTech DEGREE EXAMINATION Basic Civil and Mechanical Engineering

### PART A (Questions)

1. Name the few type of cements used in construction.
  - (1) Rapid hardening cement
  - (2) Sulphate resisting cement
  - (3) Low heat cement
  - (4) Quick setting cement
  - (5) Portland pozzolona cement
  - (6) White cement
2. What is meant by surveying?

**Surveying:** Surveying is an art of determining the relative positions of distinctive features on the earth's surface. This is achieved by the measurement of distances, directions and elevations.
3. State the purpose of dams.
  - (1) To store water during rainy season and used for irrigation and drinking purposes.
  - (2) A dam with green surroundings forms an excellent place for recreation purposes such as boating, swimming, etc.
  - (3) If sufficient water is stored, it can be used for power generation.
4. Define elasticity.

**Elasticity:** When a material is subjected by external load it undergoes deformation, but when the load is released it regains its original size and shape immediately. This property of the material is known as elasticity.

5. How are pumps classified?
6. List the important parts of gas turbine power plant.
7. How IC engines are classified?
8. Define Boiler in power plant.
9. What are the factors, which affect the comfort air-conditioning?
10. Define tonne of refrigeration.

### Part B

11. (a) Explain the principal of leveling.  
(b) Classify bricks and state its characteristics and uses of each one of them.
12. (a) What do you understand by the term foundation? Draw sketches to show various types of shallow foundations.  
(b) (i) What is dam and what are the points to be considered for the selection of site for the dam.  
(ii) What are the points to be observed in construction of stone masonry.
13. (a). Explain with neat sketch of steam power plant.  
(or)
13. (b). Explain with a neat sketch of Nuclear power plant.
14. (a). Differentiate between two stroke and four stroke engine.  
(or)
14. (b). Discuss the working of four stroke cycle petrol engine with the help of neat sketch.
15. (a). Explain with a neat sketch of Domestic Refrigerator.  
(or)
15. (b). Describe with the help of a diagram, Vapour Compression Refrigeration system.

# MODEL QUESTION PAPER-3

## BE/BTech DEGREE EXAMINATION Basic Civil and Mechanical Engineering

### PART A (Question and Answers)

1. What are different types of steel?

- (1) Mild steel
- (2) Tor steel
- (3) Bars
- (4) Plates
- (5) Flats
- (6) Angle sections
- (7) Channel sections

2. What is meant by leveling?

It is defined as an art of determining the relative heights of points on the earth's surface.

3. Define elasticity.

**Elasticity:** When a material is subjected by external load, it undergoes deformation, but when the load is released it regains its original size and shape immediately. This property of the material is known as elasticity.

4. List the different types of bonds in brick masonry.

- (1) Stretcher bond
- (2) Header bond
- (3) English bond
- (4) Flemish bond

5. Mention any three parts of steam power plants.
6. How turbines are classified?
7. Define boiler.
8. Name the cooling systems used for I.C. engines.
9. What are factors which affect the comfort air-conditioning?
10. Define COP.

### **PART – B**

11. (a) Describe the different types of concrete.  
(b) Explain the classification, qualities and constituents of a brick.
12. (a) What do you understand by a foundation. Draw sketches to show various types of shallow foundations.  
(b) What are the factors influencing the selection of dam? Explain with neat diagram any one type of dam.
13. (a) Explain with a neat sketch about a Thermal (steam) power plant.  
(or)
13. (b) Explain the working principle of a single acting reciprocating pump with the help of a line sketch, naming all main parts.
14. (a) Differentiate between two stroke and four stroke engines.  
(or)
14. (b) Explain with neat sketch of Diesel plane plant.
15. (a) Explain with neat sketch of a Domestic Refrigerator.  
(or)
15. (b) Describe with help of suitable diagram vapour compression refrigeration system.





# INDEX

- Abutments 6.4
- Aerial surveying 2.4
- Afflux 6.6
- Allowances 1.41, 1.42
- Approaches 6.5
- Archaeological surveys 2.3
- Arc welding 1.61
- Ashlar Masonry 5.14
  - Ashlar block-in-course 5.15
  - Ashlar chamfered 5.15
  - Ashlar facing 5.15
  - Ashlar fine 5.14
  - Ashlar rock or quarry faced 5.15
  - Ashlar rough – tooled 5.15
- Astronomical survey 2.3
- Atomic power stations in india 8.7
- Automobile 1.75
  
- B**
- Babcock and wilcox boiler 9.8
- Bacteriological tests 1.20
- Ballast 1.32
- Barrage 8.21
- Basin 1.50
- Batten board 3.46
- Battens 5.31
- B-coli test 1.20
- Beams 5.18
  - Girders 5.18
  - Joists 5.18
  - Lintels 5.18
  - Spandrels 5.19
  - Stringers 5.19
- Bearing 2.11
  - Back Bearing (BB) 2.12
  - Fore Bearing (FB) 2.12
  - Magnetic bearing 2.12
  - Reduced Bearing (RB) 2.12
  - True bearing 2.12
  - Whole Circle Bearing (WCB) 2.12
- Bearing capacity of soil 4.6
- Bearings for the girders 6.5
- Bed joint 5.11
- Bellows 1.50
- Benson boiler 9.10
- Bentonite 1.49
- Betterment charges 5.58
- Boiler mountings 9.4
  - Blow-off valve 9.6
  - Fusible plug 9.6
  - Main steam valve 9.5
  - Pressure gauge 9.4
  - Safety valve 9.5
  - Water gauge 9.4
- Boiling water reactor 8.4
- Bonds in brick work 1.69
  - English 5.3
    - One-and-a-half brick wall 5.4
    - One-brick wall 5.5
  - Flemish 5.4
  - Garden wall 5.5
    - Garden wall english 5.7
    - Garden wall flemish 5.7
- Header 5.7
- Raking 5.3
  - Diagonal 5.7

- Herringbone 5.7
- Stretcher 5.7
- Zig-zag 5.3
- Braze welding 1.67
- Brazing 1.65
- Brazing metals 1.66
- Brick masonry 1.30
  - Arrises 5.1
  - Bed joint 5.2
  - Closer 5.2
    - Bat 5.3
    - Bevelled 5.3
    - Bullnose 5.3
    - Cownose 5.3
    - King 5.3
    - Mitred 5.3
    - Queen 5.3
    - Squint quoin 5.3
  - Header 5.3
  - Lap 5.2
  - Perpends 5.2
  - Stretcher 5.2
- Bricks 5.2
  - Burning 3.5
  - Classification 3.10
  - Constituents 3.5
  - Drying 3.6
  - Manufacture 3.10
  - Moulding 3.9
    - Ground moulding 3.9
    - Hand moulding 3.10
    - Machine moulding 3.9
    - Table moulding 3.10
  - Preparation 3.10
  - Preparation of brick earth
    - Blending 3.9
    - Digging, spreading and cleaning 3.9
    - Removal of loose soil 3.9
    - Tempering 3.9
    - Weathering 3.9
  - Qualities 3.5
  - Tests 3.7
  - Uses 3.6
- British road 3.49
- Building materials 3.51
  - Mechanical properties 3.49
  - Physical properties 8.14
- Butane boiler 8.17
- C**
- Cadastral surveys 2.3
- Cadmium 1.67
- Caisson foundation 4.16
- Cams 11.3
- Carburetter 11.11
- Carburising flame 1.64
- Carriage 1.69
- Casing 10.5
  - Casing with guide vanes or diffuser casing 10.6
  - Volute 10.6
  - Vortex 10.6
- Casting 1.59, 1.64, 1.61
- Catchment 1.23
- Catchment area 6.2
- Causeway 6.6
- Causeways 6.16
  - Causeways with vents 6.17
  - Flush causeways 6.17
  - High-level causeways 6.17
- Cement 3.15
  - Qualities 3.15
  - Types 3.16
    - Air-entraining 3.17
    - Coloured 3.17
    - Expansive 3.17
    - High-alumina 3.17
    - High-strength 3.17
    - Hydrophobic 3.17
    - Low-heat 3.17
    - Masonry 3.17
    - Portland pozzolana 3.17
    - Quick-setting 3.17
    - Rapid-hardening 3.16
    - Sulphate-resisting 3.17
    - White 3.17
  - Uses 3.16
- Cement concrete 3.23
  - Non-destructive tests for concrete 3.33
  - Properties 3.23
  - Rebound test method 3.33
  - Reinforced concrete 3.24
  - Testing of fresh and hardened concrete 3.28
  - Types 3.25
    - Fibre-reinforced concrete 3.27

- High-density concrete 3.26
  - Light-weight concrete 3.25
  - Polymer concrete 3.26
  - Ultrasonic method 3.34
  - Uses 3.23
  - Central air conditioning 12.10
  - Centrifugal pumps 10.4
  - Chain 2.6
  - Chain surveying 2.4
  - Chain surveying 2.8
    - Base line 2.8
    - Check line 2.9
    - Main survey station 2.8
    - Offset 2.9
    - Tie line 2.9
    - Tie stations 2.8
  - Chlorides 1.18
  - City surveying 2.3
  - Civil engineering 3.1
  - Classification of bridges 6.6
    - Arch bridge 6.9
    - Bascule bridge 6.14
    - Bow-string girder bridge 6.10
    - Deck bridges 6.6
    - Movable bridges 6.14
    - Non-submersible or high-level 6.8
    - Overbridge 6.8
    - Permanent bridges 6.6
    - Plate-girder bridges 6.13
    - Semi-through bridge 6.7
    - Skew bridge 6.7
    - Slab bridge 6.9
    - Steel arch bridges 6.13
    - Steel bow-string girder bridges 6.14
    - Steel bridges 6.11
    - Steel rigid-frame bridge 6.12
    - Steel truss bridges 6.11
    - Straight bridge 6.7
    - Submersible or low-level 6.8
    - Suspension bridge 6.10
    - Swing bridge 6.14
    - T-beam and slab bridge 6.9
    - Temporary bridges 6.6
    - Through bridge 6.7
    - Underbridge 6.8
    - Vertical lift bridge 6.14
  - Cochran boiler 9.2
  - Cogeneration 9.12
  - Coil-ignition system 11.13
  - Coke 1.19
  - Columns 5.23
    - Rcc columns 5.24
    - Stanchions 5.24
    - Steel columns 5.24
  - Comfort air conditioning 12.7
  - Compass 2.10
    - Prismatic compass 2.10
    - Surveyor's compass 2.11
  - Compass surveying 2.4
  - Compression ratio 11.4
  - Compression stroke 11.5
  - Compulsory acquisition 5.58
  - Concentration of metals 1.62
  - Connecting rod 11.3
  - Consumable 1.39
  - Contouring 2.29
  - Contraction 1.68
  - Control 1.46
  - Cooling system in IC engines 11.15
    - Air cooling 11.16
    - Water cooling 11.16
  - Cope and drag pattern 1.51
  - Coping 5.12
  - Corbel 5.11
  - Cores 1.70
  - Cornice 5.12
  - Corrosive 1.67
  - Course 5.11
  - Court fees, registration charges 5.58
  - Cramp 5.12
  - Crank shaft 11.3
  - Crucible furnace 1.56
  - Culvert 6.5
  - Culverts 6.14
    - Arch culvert 6.16
    - Box culvert 6.14
    - Pipe culvert 6.15
  - Cupola furnace 11.2
  - Cylinder 11.3
- D**
- Dalton's atomic theory 8.4
  - Damp-proofing 5.51
  - Dead load 4.7

- Deep foundation 4.14
  - Composite piles 4.15
  - Pile foundation 4.14
  - Steel pile 4.15
  - Timber pile 4.15
  - Under-reamed piles 4.14
- De-laval turbine 9.14
- Dextrin 1.49
- Diesel power plant 8.10
- Differential levelling 2.22
- Dissolved gas 1.18
- Drawing 1.34
- Dressing of stones 1.76
  - Axed finish 5.10
  - Chisel 5.10
  - Hammer 5.10
  - Polished finish 5.10
- Drilling machine 1.74
- Dry air 12.7
- Dry-bulb temperature 12.7
- Dug well 1.25
- Dust 1.48
- E**
- Eave board 5.31
- Electrodes 1.62
- Electronic methods of measuring distance 2.9
- Endothermic 1.56
- Engineering surveys 2.3
- Environmental constraints
  - Acid fog 8.15
  - Acid rain 8.15
  - Acid snow 8.15
  - Dry acidic deposition 8.15
  - Global warming 8.15
  - Greenhouse effect 8.15
  - Particulate matter 8.15
- Environmental engineering 1.26
- Ethical principle 1.38
- Exhaust stroke 11.5, 11.7
- F**
- Failure of foundations 4.17
- Ferrous 1.40
- Filter 1.24
- Fire brick 1.53, 55
- First flush 1.24
- Flat roofs 5.28
- Floor beams 5.19
- Flooring 5.40
  - Floor covering 5.42
  - Subfloor 5.40
- Fluidity 1.59
- Fluid mechanics 3.3
- Flux 1.55
- Flux removal 1.68
- Flywheel 11.3
- Follow board pattern 1.45
- Foundation design 1.6
- Foundations 6.5
  - Foundations for machinery 4.18
    - Heavy rotary type machines 4.20
    - Impact type machines 4.19
  - Foundations for special structures 4.21
    - Chimneys 4.22
    - Cooling towers 4.22
    - Ground storage tanks 4.28
    - Guyed structures 4.27
    - Industrial structures 4.27
    - Silos 4.21
    - Telecommunication towers 4.23
    - Transmission line towers 4.23
    - Water tanks 4.21
- Foundation soil 4.2
- Four-stroke petrol engine 11.4
- Free board 6.6
- Fuel injector 11.20
- Fuel pump 11.19
- Functions of a civil engineer 3.4
  - Design 3.4
  - Execution 3.4
  - Investigation 3.4
  - Planning 3.4
  - Research and development 3.5
  - Surveying 3.4
- G**
- Gas-cooled reactor 8.6
- Gas cutting 1.65
- Gas turbines 8.8
  - Closed-cycle 8.10
  - Open-cycle single-stage 8.8
- Gas welding 1.63
- Gated pattern 1.46

Gauge 1.31  
Gearing 1.70  
Geodetic surveying 2.2  
Geological surveys 2.3  
Geotechnical engineering 1.6, 3.2  
Geothermal power 8.21  
Grains 1.59  
Graphite 1.57  
Gravity dam 1.49  
Green sand moulding 7.11  
Guard stones 6.5

## H

Hand rails 6.5  
Hardness 1.18  
Head room 6.6  
Head stock 1.69  
Hearting 5.12  
High Flood Level (HFL) 6.2  
Hydraulic machines 3.3  
Hydraulics 3.3  
Hydroelectric power plant 8.12  
Hydrogen-ion concentration 1.19

## I

Impeller 10.5  
Impurities 1.55  
Indian boiler act 9.11  
Infiltration galleries 1.12  
Infiltration wells 1.13  
Insurance 5.58  
Internal stresses 1.42  
Irrigation engineering 3.4

## J

Jambs 5.12  
Jolt and squeeze machines 1.53, 1.51  
Jolt machines 1.52

## K

Kinetic energy 1.52  
King-post truss 5.36

## L

Lacing course 5.11  
Ladle 1.57  
Lakes 1.10

Lamont boiler 9.9  
Land surveying 2.2  
Lathe 1.68  
Length of the bridge 6.6  
Level 2.19  
    Dumpy levels 2.20  
    Levelling staff 2.20  
Levelling 2.17  
    Back sight (BS) 2.17  
    Benchmark (BM) 2.17  
    Change point (CP) 2.17  
    Datum surface 2.17  
    Fore Sight (FS) 2.17  
    Horizontal plane 2.17  
    Intermediate Sight (IS) 2.17  
    Level surface 2.17  
    Principle 2.18  
    Reduced Level (RL) 2.17  
    Vertical plane 2.17  
Lintels 5.25  
    Brick 5.25  
    RCC 5.27  
    Steel 5.27  
    Stone 5.25  
    Wood 5.25  
Lintels or heads 5.12  
Live load 4.7  
Locomotive boiler 9.7  
Loose piece pattern 1.44  
Low Water Level (LWL) 6.5  
Lubrication system 11.17

## M

Magneto-ignition system 11.15  
Marine (or) hydrographic surveys 2.3  
Match plate pattern 1.44  
Measurement of angles 2.9  
Measurement of distances 2.5  
    Chaining 2.6  
    Odometer 2.6  
    Pacing 2.6  
    Passometer 2.6  
    Pedometer 2.6  
    Speedometer 2.6  
Mechanism 1.69  
Melting point 1.55  
Methods of refrigeration 12.3

- Domestic 12.4
- Vapour-absorption 12.5
- Vapour-compression 12.3
- Mid-ordinate rule 2.28
- Military or defence surveys 2.3
- Mine surveys 2.3
- Moist air 12.7
- Moisture 1.51
- Mortar 3.18
  - Properties 3.20
  - Selection 3.20
  - Types 3.18
    - Bricklaying mortars 3.19
    - Cement mortar 3.19
    - Finishing mortars 3.19
    - Fire-resistant mortar 3.19
    - Gauged mortar 3.19
    - Gypsum mortar 3.19
    - Heavy 3.18
    - Lightweight 3.18
    - Lightweight mortar 3.19
    - Lime mortar 3.18
    - Packing mortar 3.20
    - Sound-absorbing mortar 3.20
    - Surkhi mortar 3.18
    - X-ray shielding mortar 3.20
  - Uses 3.20
- Moulding machines 1.48
- N**
- Natural bed 5.11
- Neutral 1.64, 1.62
- Non-consumable 1.62
- Non-rigid dams 7.9
  - Earth dams 7.9
    - Diaphragm-type embankments 7.10
    - Homogeneous embankment type 7.9
    - Zoned embankment type 7.9
  - Rock-fill dams 7.10
- Nuclear fission 8.4
- Nuclear power plant 8.3
- Nuclear waste disposal 8.7
- O**
- Oceans 1.12
- Ocean Thermal Energy Conversion (OTEC) 8.22
  - Closed cycle 8.23
  - Open-Cycle 8.23
- Odour 1.18
- Ordinary Flood Level (OFL) 6.5
- Oxidizing 1.63
- Oxy-acetylene welding 1.63
- P**
- Parson's reaction turbine 9.16
- Parts of a steam turbine 9.13
  - Blades 9.14
  - Casing 9.14
  - Nozzles 9.13
  - Rotor 9.14
- Patterns 2.2
- Percolation tanks 1.21
- Petroil method 11.18
- Petrol engine 11.11
- Petrol injection 11.21
  - Continuous injection 11.21
  - Timed injection 11.21
    - Low-pressure single-pump and distributor system 11.21
    - Multiple-plunger jerk pump system 11.21
- Photographic surveying 2.4
- Physical and chemical standards (MUD, India) 5.11
- Piers 1.71
- Pin header 5.31
- Pinion 1.69
- Piston 11.3
- Piston rings 11.3
- Pitch 2.2
- Plane surveying 2.2
- Plane table surveying 2.4
- Plastering 5.54
- Plastics 3.46
- Plinth 1.10
- Plywood 8.3
- Ponds 2.2
- Pressure lubricating system 11.18
- Pressurised Water Reactor (PWR) 8.5
- Principles of stone masonry 3.44
- Principles of surveying 2.4
- Private development 3.44
- Properties of wood 3.45
  - Colour 3.45
  - Grain 3.44
  - Moisture content 3.45

- Odour 3.44
  - Shrinkage 3.45
  - Specific gravity 3.45
  - Strength 5.32
- Q**
- Queen-post truss 5.36
  - Quoins 5.11
- R**
- Rafter 5.31
  - Railway engineering 1.31
  - Rainwater harvesting 1.22
  - Recharge pits 1.25
  - Recharge shafts 1.25
  - Recharge trench 1.25
  - Reciprocating pumps 10.2
    - Double-acting 10.3
    - Single-acting 10.2
  - Reinstatement 5.58
  - Relative humidity 12.7
  - Remote sensing 3.4
  - Rent determination 5.58
  - Reveals 5.12
  - Ridge piece 5.31
  - Rigid dams 7.4
    - Arch dams 7.5
    - Buttress dam 7.7
    - Solid gravity dams 7.4
    - Timber and steel dams 7.8
  - Rise 5.35
  - Rise and fall method 2.25
  - Rivers 1.11
  - Roman roads 1.29
  - Roof coverings 5.39
    - Asbestos–cement corrugated sheets 5.39
    - Corrugated galvanised iron sheets 5.39
    - Eternit slates 5.39
    - Half-round tiles 5.39
    - Patent tiles 5.39
    - Ruberoid 5.40
    - Shingles 5.39
    - Thatch 5.39
    - Trafford asbestos cement tiles 5.39
  - Roofing 5.28
  - Rubble masonry 5.12
    - Polygonal rubble masonry 5.14
    - Random rubble masonry 5.13
      - Coursed 5.13
      - Uncoursed 5.13
    - Squared rubble masonry 5.13
      - Coursed 5.14
      - Un-coursed 5.13
- S**
- Safety precautions for nuclear power plant 8.6
  - Sand 3.21
    - Artificial 3.21
    - Natural 3.21
    - Qualities 3.21
    - Tests 3.22
      - Sieve analysis and fineness modulus test 3.22
      - Test for bulkgage of sand 3.22
      - Test of silt content 3.23
    - Uses 3.22
  - Sand slingers 1.53
  - Sanitary and environmental engineering 3.3
  - Saturated air 12.7
  - Seasoning of timber 3.44
    - Air seasoning 3.44
    - Boiling 3.44
    - Chemical seasoning 3.44
    - Electrical seasoning 3.44
    - Kiln seasoning 3.44
    - Natural seasoning 3.44
    - Water seasoning 3.44
  - Security of loans 5.58
  - Shallow foundation 4.7
    - Cantilever footing 4.12
    - Combined footing 4.9
    - Continuous footing 4.12
    - Grillage foundations 4.13
    - Inverted arch footing 4.13
    - Isolated footing 4.8
    - Mat foundation 4.13
    - Raft foundation 4.13
    - Strip footing 4.10
    - Wall footing 4.8
  - Shell 1.56
  - Shell pattern 1.46
  - Shrinkage 1.58
  - Sill 5.12
  - Simple levelling 2.21

- Simpson's rule 2.27
- Skeleton pattern 1.45
- Slag 1.55
- Sloping roof 5.30
- Sloping roofs 5.32
  - Double or purlin roof 5.34
  - Single roof 5.32
    - Collar beam roof 5.33
    - Coupled close roof 5.33
    - Coupled roof 5.33
    - Lean-to-roof 5.32
  - Trussed roofs 5.35
- Smart city development 1.34
- Soak away 1.25
- Soil classification 4.4
- Soil investigation 1.6
- Soils 4.3
  - Clay 4.4
  - Gravel 4.3
  - Sand 4.3
  - Silt 4.4
- Solar energy 8.15
- Solar heaters 8.16
  - Parabolic reflector 8.16
  - Solar flat-plate collector 8.16
- Solar-power generation 8.17
- Solar refrigerator 12.6
- Soldering 1.67
- Solid pattern 1.44
- Spalls 1.44
- Span 1.13
- Spark plug 11.14
- Speculation 1.52
- Splash lubrication 11.18
- Split air-conditioner 12.9
- Split pattern 1.42
- Springs 1.11
- Squeezers 5.11
- Steam power plants 8.1
- Steel 5.31
- Steel band 2.7
- Steel roof truss 1.56
- Steel sections 2.5
  - Angle sections 1.33
  - Bars 1.45
  - Channel sections 2.1
  - Expanded metal 2.1
  - Flats 5.36
  - I-sections 3.34
  - Plates 3.35
  - Steel as a reinforcing material 3.35
    - Forms 3.36
    - Properties 3.37
    - Types 3.35
    - Usage 3.36
  - T-sections 3.35
- Stone masonry 3.38
- Stones 3.38
  - Dressing 3.40
  - Qualities 3.39
  - Quarrying 3.40
  - Testing 3.37
    - Acid test 5.9
    - Attrition test/abrasion test 3.10
    - Crystallization test 3.12
    - Electrical resistance/ water absorption test 3.11
    - Fire resistance test 3.12
    - Freezing and thawing test 3.12
    - Hardness test 3.13
    - Impact test 3.13
    - Microscopic test 3.13
    - Smith's test 3.13
    - Test for crushing strength 3.13
  - Types of building stones 3.14
    - Basalt and trap 3.12
    - Chalk 3.13
    - Gneiss 3.14
    - Granite 3.13
    - Gravel 3.13
    - Laterite 3.14
    - Limestone 3.14
    - Marble 3.14
    - Quartzite 3.15
    - Sandstone 3.14
    - Slate 3.15
  - Uses 3.14
- Streams 3.14
- String course 3.15
- Structural engineering 3.15
- Struts 3.14
- Substructure 3.12, 4.2
- Suction stroke 11.4
- Superheating 3.2



- Superstructure 4.2
- Surveying 5.35
  - Objectives 4.2
  - Types 6.4
- Sweep pattern 6.4
  
- T**
- Tacheometric surveying 2.4
- Tail stock 1.69
- Taste 1.18
- Taxation 5.58
- Temperature 1.18
- The height of collimation or height of instrument method 2.24
- Theodolite surveying 2.4
- Thermal springs 8.21
- Thermoelectric cooling 12.11
- Thermoplastics 1.33
  - Acrylic 3.47
  - Cellulose acetate 3.48
  - Perpex 3.48
  - Polythene 3.48
  - Poly vinyl chloride 3.48
- Thermo-setting plastics 3.48
  - Phenol formaldehyde 3.48
  - Phenol-furfuraldehyde 3.48
  - Urea-formaldehyde 3.48
- Throating 3.48
- Through stone or bond stones 5.12
- Tidal power 8.20
- Ties 5.12
- Ton of Refrigeration (TR) 12.1
- Topographical surveys 2.2
- Town planning 5.35
- Transportation 2.2
- Transportation engineering 1.27
- Trapezoidal rule 2.26
- Traverse surveys 2.3
  - Closed traverse 2.3
  - Open traverse 2.4
- Truss 11.10
- Turbidity 11.8
- Two-stroke diesel engine 5.19
- Two-stroke petrol engine 5.19
- Types of beams 5.20
  - Cantilever 5.21
  - Continuous 5.19
  - Doubly reinforcement 5.21
  - Fixed 5.19
  - Overhanging 5.21
  - Simply supported 5.23
  - Singly reinforcement 5.43
  - Steel beams 5.48
- Types of flooring 5.44
  - Asphalt 5.45
  - Brick 5.51
  - Cement concrete 5.46
  - Granite 5.50
  - Granolithic 5.47
  - Industrial 5.47
  - Marble 5.44
  - Mosaic 5.45
  - Mud and moorum 5.46
  - Stone 5.48
  - Terrazzo 5.55
  - Wood or timber 5.55
- Types of plasters 5.55
  - Cement 5.55
  - Lime 5.55
  - Mud 5.37
  - Waterproof 5.38
- Types of refrigerants 12.2
  - Ammonia 12.3
  - Freon-12 12.2, 12.3
  - Freon-22 12.3
- Types of steel roof trusses 5.38
  - Bowstring steel truss 5.38
  - Compound fink steel truss or french truss 5.37
  - Compound howe's steel truss 5.38
  - King post steel truss 5.37
  - North light steel truss 5.38
  
- V**
- Valuation 5.57
- Valuation of building 5.59
  - Area-based 5.60
    - Carpet-area 5.61
    - Plinth-area 5.60
  - Based on cost 5.59
  - Based on profit 5.59
  - Depreciation method 5.59
  - Development method 5.59
  - Direct comparison with capitalised 5.59
  - Rental method 5.59

Vent way 6.5

Viaduct 6.6

## W

Wall plate 5.31

Water supply 3.3

Water turbines 8.13

    Francis turbine 8.13

    Kaplan turbine 8.13

    Pelton wheel 8.13

Waterway 1.41

Wear 1.63

Weathering 6.5

Welding 1.14

Well foundation 4.16

Wells 4.14

Wet bulb temperature 12.7

Wind energy 8.18

Wind load 4.7

Windmills 8.19

Window air conditioner 12.8

Wing walls 3.42

Wood 3.43

    Exogenous tree 3.43

        Bark 6.4

        Cambium 3.43

        Heartwood 3.43

        Medullary rays 3.43

        Pith 3.43

        Sapwood 3.43

    Hard timber 3.42

    Soft timber 11.7

Working of a four-stroke diesel engine 11.5

## Z

Zones 1.56

Zoning 1.33