



SNS COLLEGE OF TECHNOLOGY

Coimbatore-35
An Autonomous Institution



Accredited by NBA – AICTE and Accredited by NAAC – UGC with 'A++' Grade
Approved by AICTE, New Delhi & Affiliated to Anna University, Chennai

DEPARTMENT OF ELECTRONICS & COMMUNICATION ENGINEERING

19ECT301- COMMUNICATION NETWORKS

III YEAR/₁V SEMESTER

UNIT V MULTILAYERING NETWORK

TOPIC 4–Next Generation Internet Architectures

Current Internet architecture

- Hourglass architecture
 - Common network layer
- Architecture has led to very successful system
- What are potential problems and limitations?

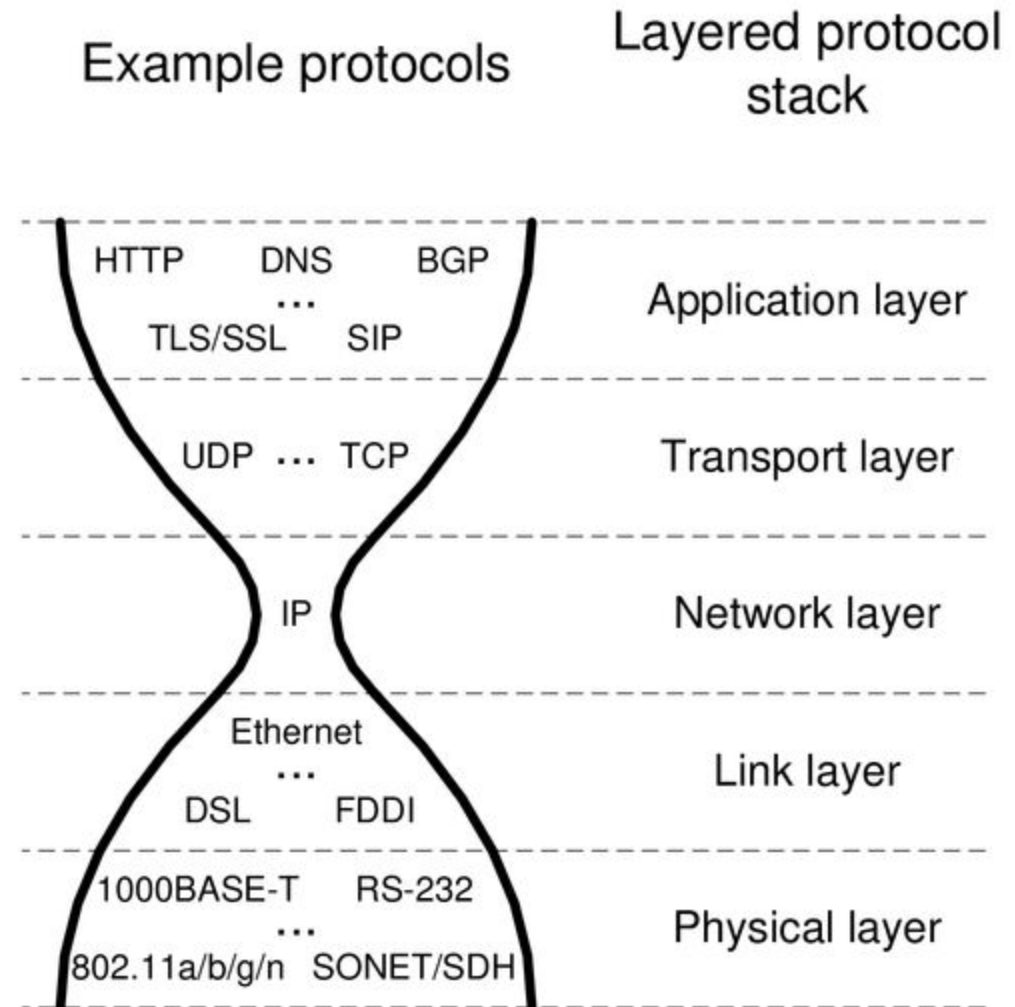

Changes in Internet

- New requirements
 - Security
 - Robustness
 - Performance guarantees
 - Etc.
- Different ways of communicating in network
 - New networking paradigms

Client-server communication

- Classic view of networking

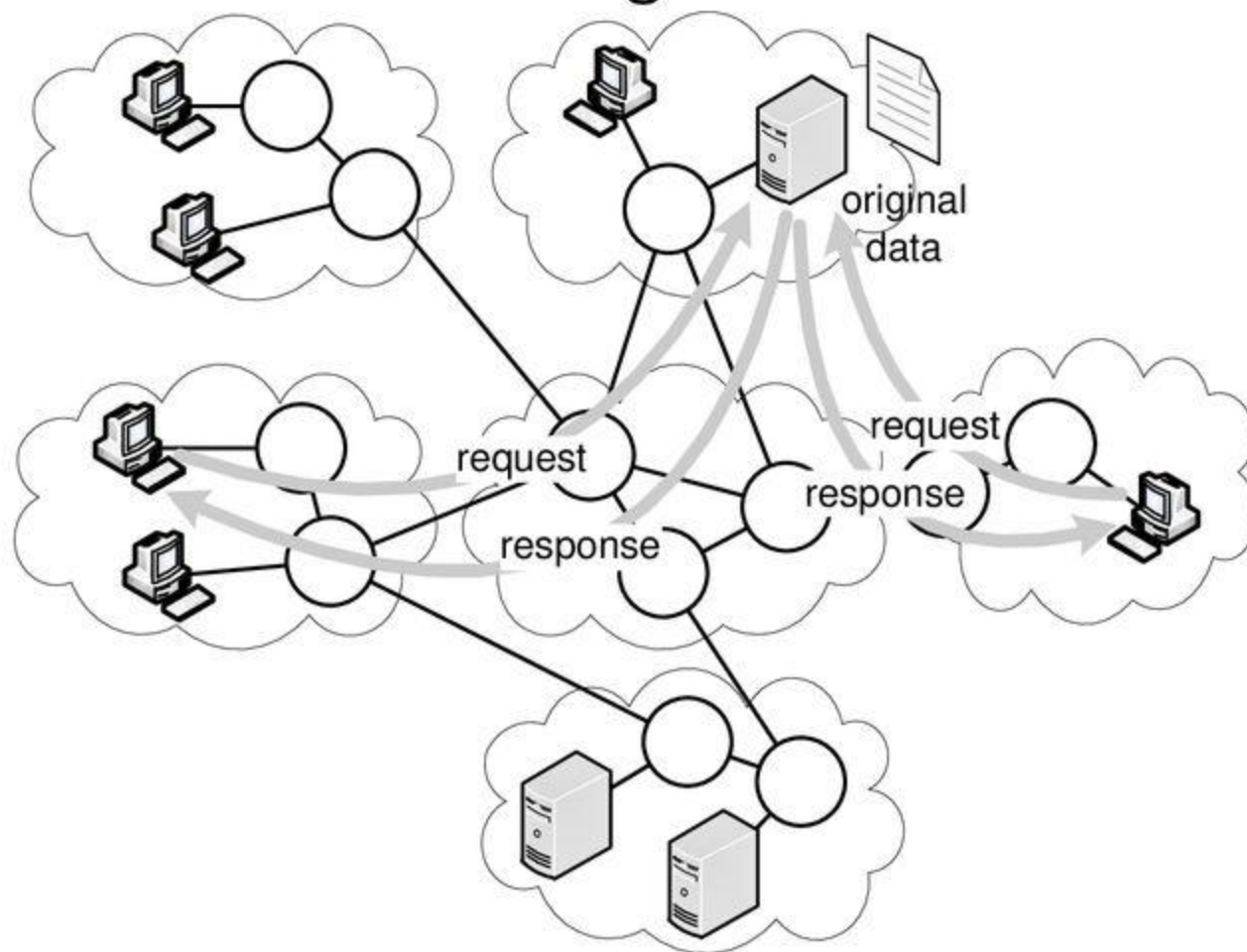

Peer-to-peer communication

- Nodes act as clients and servers

- Where is the main challenge?

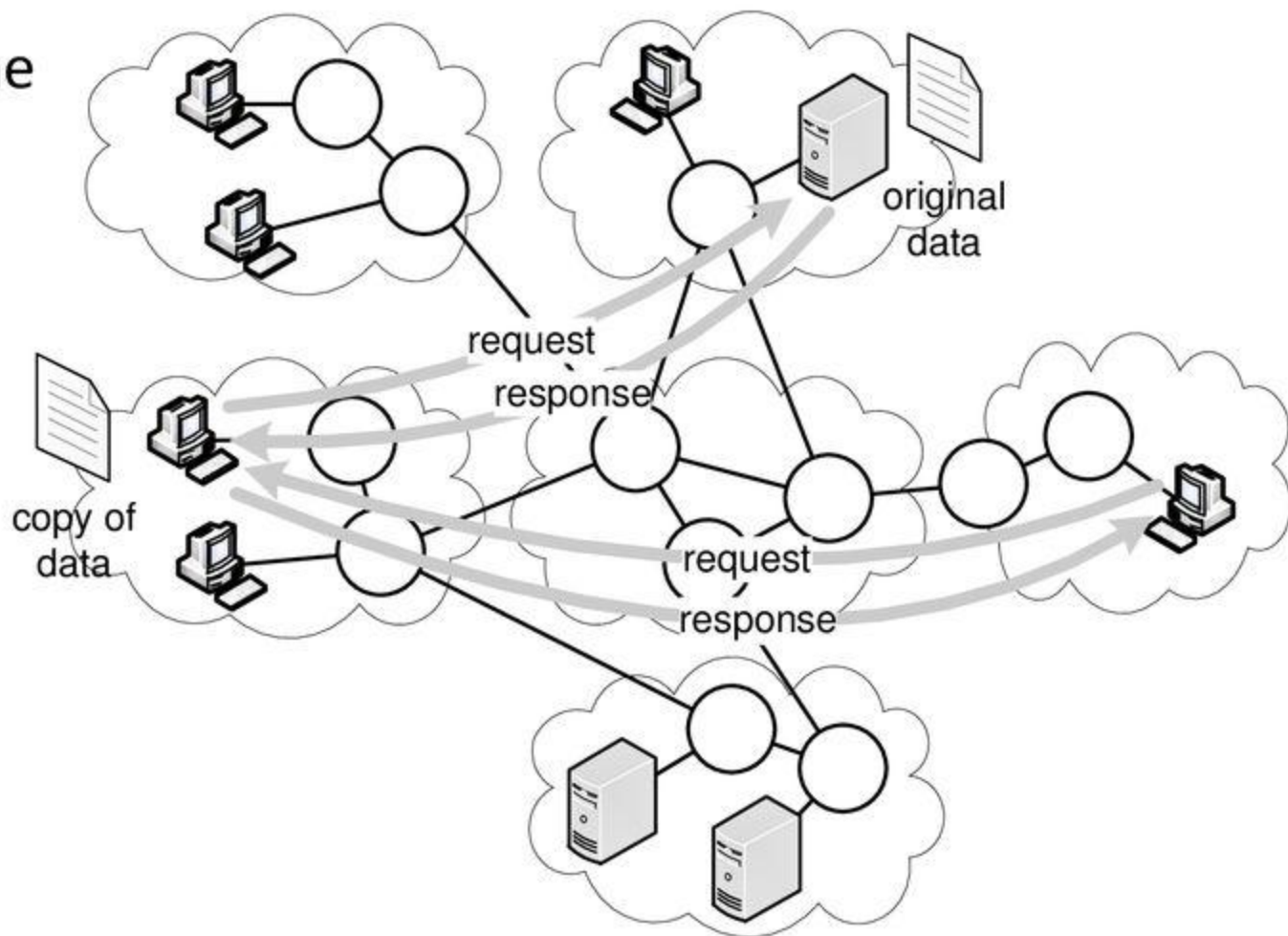

Content distribution

- “Pushing” of content towards nodes

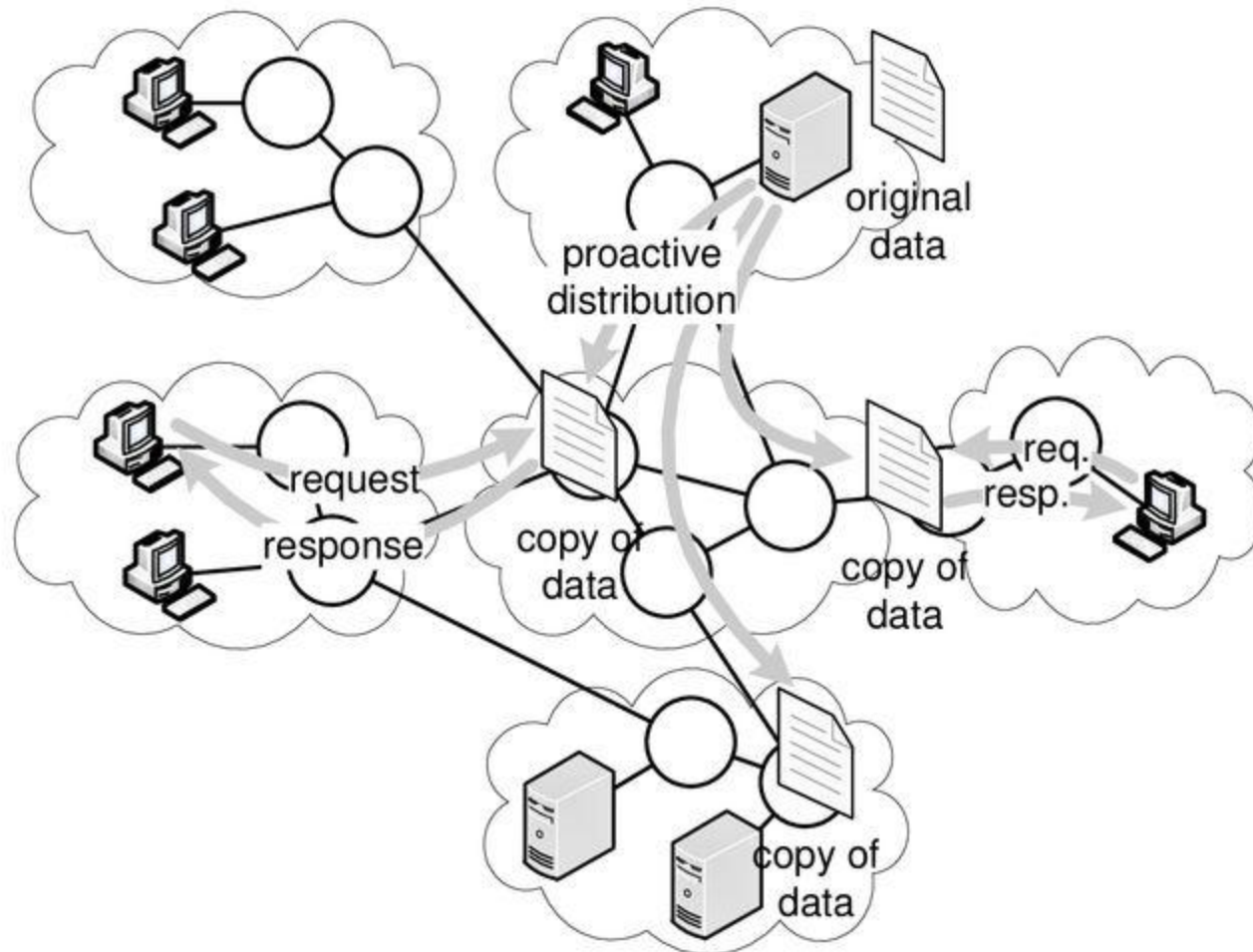

Information fusion

- Sensor network
 - Computation inside network (e.g., aggregation)

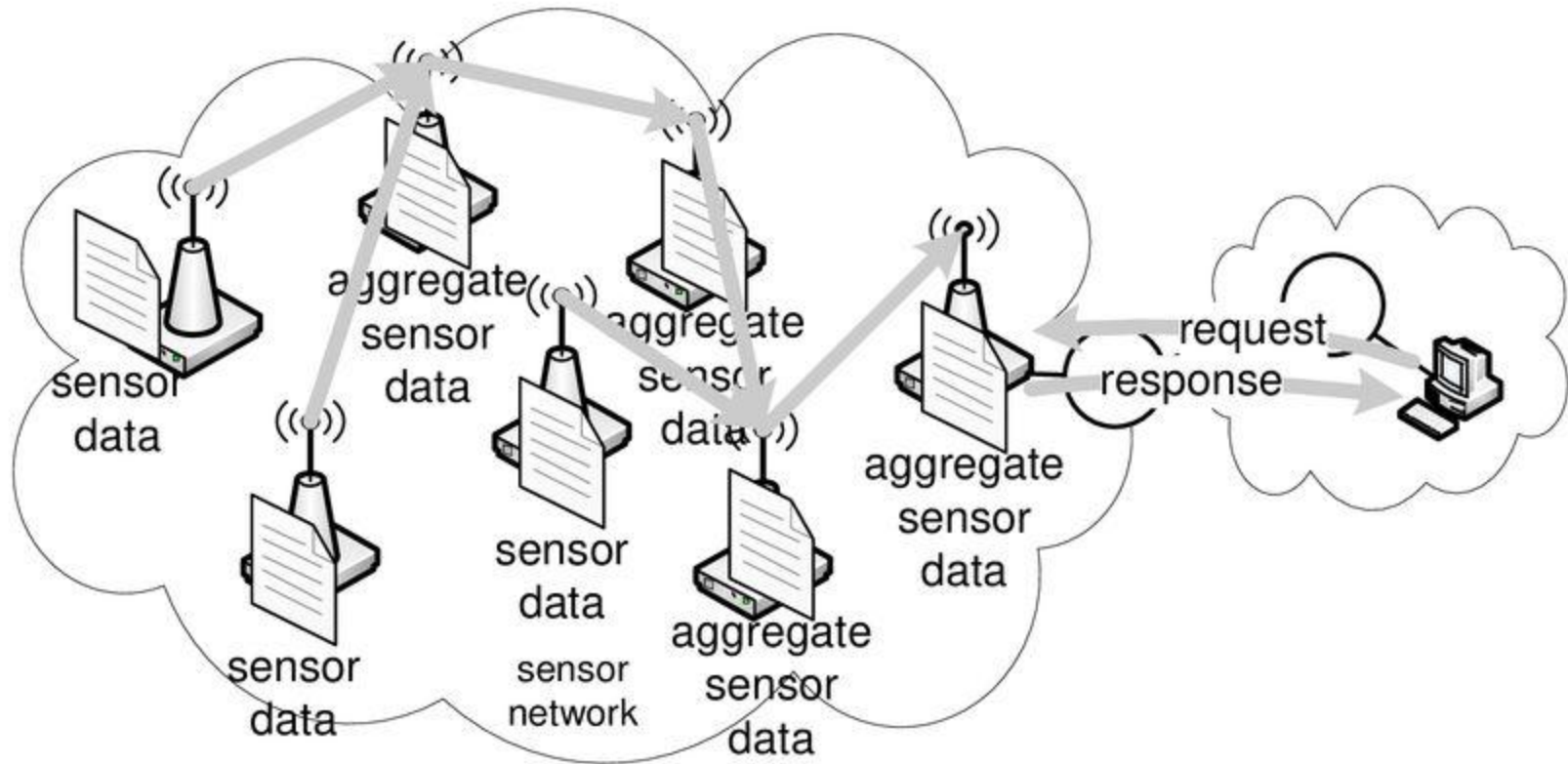

Delay-tolerant networks

- Links with very long delay / intermittent availability
 - Satellites
 - Data carriers

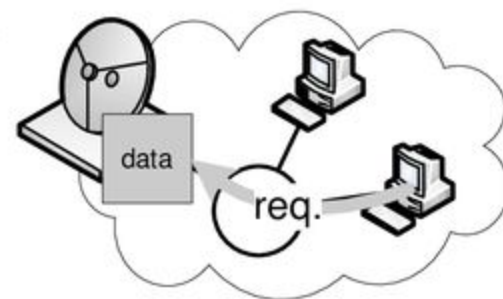
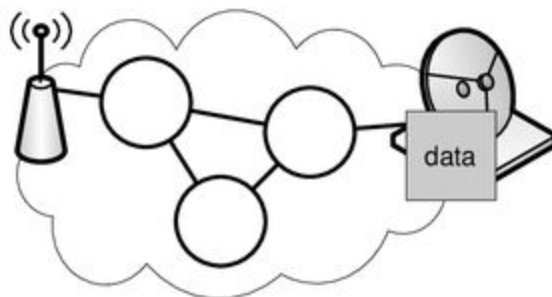
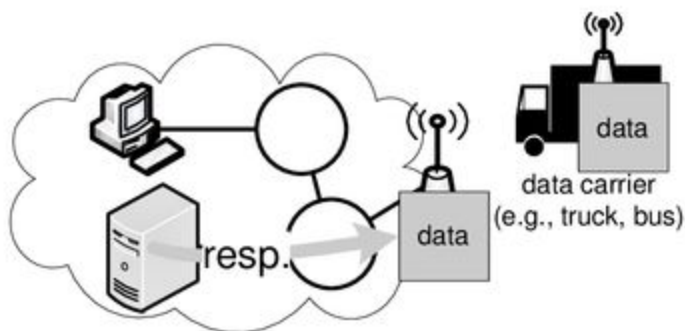

Implications for network architecture

- Diverse demands on network
 - New requirements
 - New communication paradigms
- Architecture needs to support all
 - Possibly conflicting demands
 - How to design one architecture?
- Architecture should support future ideas
 - Expensive to change infrastructure

Network virtualization

- Virtualized network
 - Single physical infrastructure
 - Multiple logical networks
 - Similar to OS virtualization
- Dynamic instantiation of new networks
 - Programmable data plane

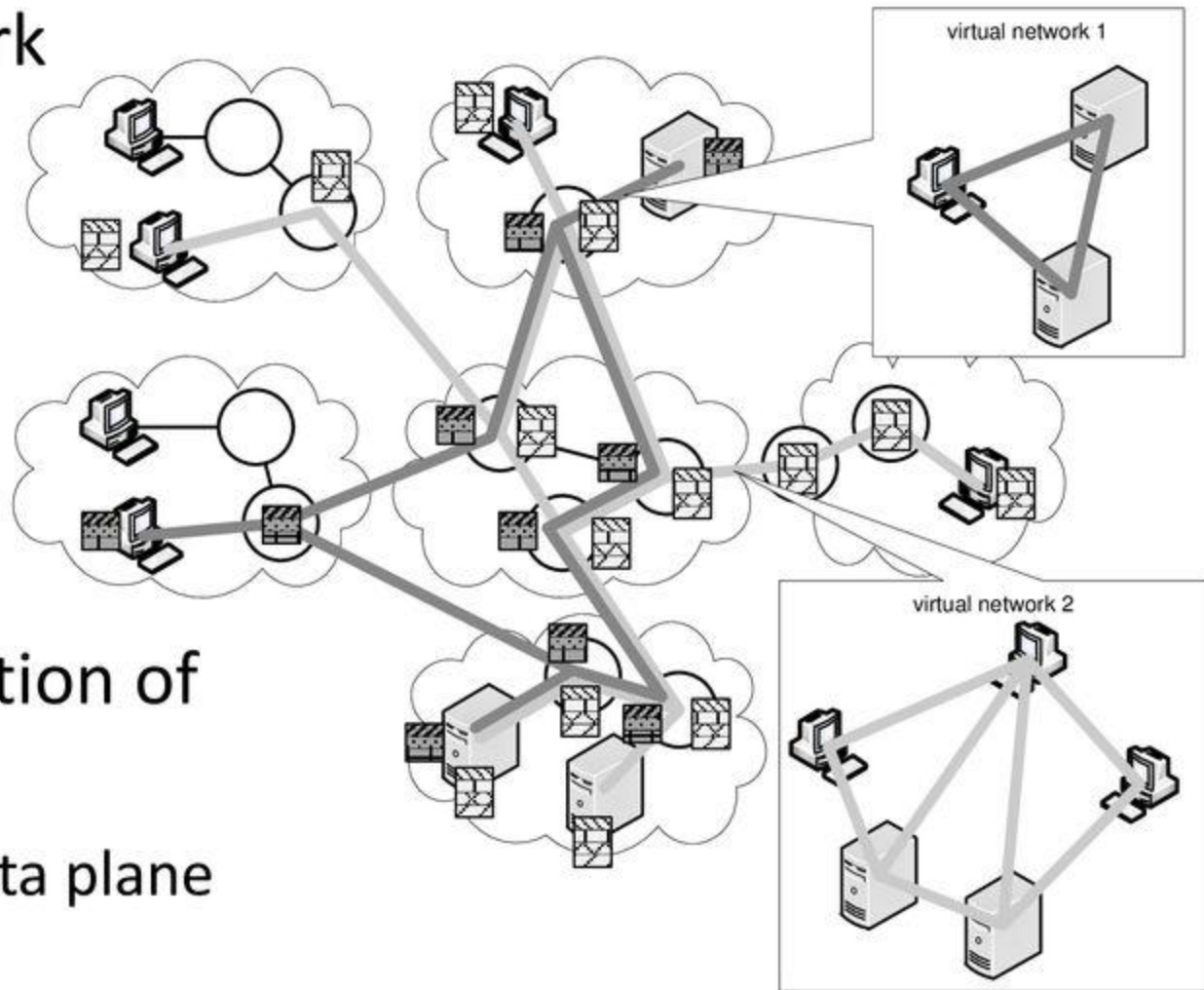

Network virtualization

- Ongoing research on network virtualization
 - Network node design (isolation, protocol processing, ...)
 - Control plane (setup, control, mgnt of virtual networks, ...)
 - New protocols for specific virtual network
- Testbed: GENI
 - Large confederation of experimental networks
 - Virtualization at core of GENI to allow experimentation
 - Model for potential future Internet
- Exiting time to be networking researcher!