



SNS COLLEGE OF TECHNOLOGY

Coimbatore-35
An Autonomous Institution



Accredited by NBA – AICTE and Accredited by NAAC – UGC with 'A++' Grade
Approved by AICTE, New Delhi & Affiliated to Anna University, Chennai

DEPARTMENT OF ELECTRONICS & COMMUNICATION ENGINEERING

23ECT212 – LINEAR CONTROL SYSTEMS

II YEAR/ IV SEMESTER

UNIT I – CONTROL SYSTEM MODELING

TOPIC 4- TRANSFER FUNCTION



OUTLINE



- REVIEW ABOUT PREVIOUS CLASS
- TRANSFER FUNCTION DEFINITION & METHODS TO FIND
- EXAMPLE PROBLEMS
- WHY LAPLACE TRANSFORM
- ACTIVITY
- APPLICATIONS OF TRANSFER FUNCTIONS
- POLES AND ZEROES
- BIBO VS TF
- SUMMARY



TRANSFER FUNCTION



Transfer Function is the ratio of Laplace transform of the output to the Laplace transform of the input. Consider all initial conditions to zero.

Where s is the Laplace operator.

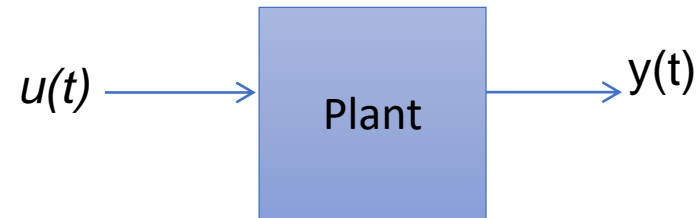

$$\text{If } \mathcal{L}u(t) = U(S) \quad \text{and} \\ \mathcal{L}y(t) = Y(S)$$



TRANSFER FUNCTION...

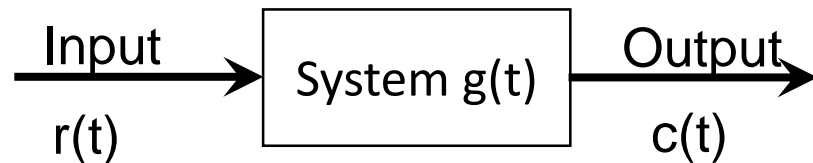

■ $g(t) = \frac{c(t)}{r(t)}$

■ *In term of Laplace transform*



■ $G(s) = \frac{C(s)}{R(s)}$

■ So, Transfer function,

$G(s) = \frac{\mathcal{L} c(t)}{\mathcal{L} r(t)} \Big|_{\text{initial conditions}=0}$



TRANSFER FUNCTION...



The transfer function $G(S)$ of the plant is given as

$$G(S) = \frac{Y(S)}{U(S)}$$





Example 1: Determine $V_o(s)/V_i(s)$ of the following circuit.

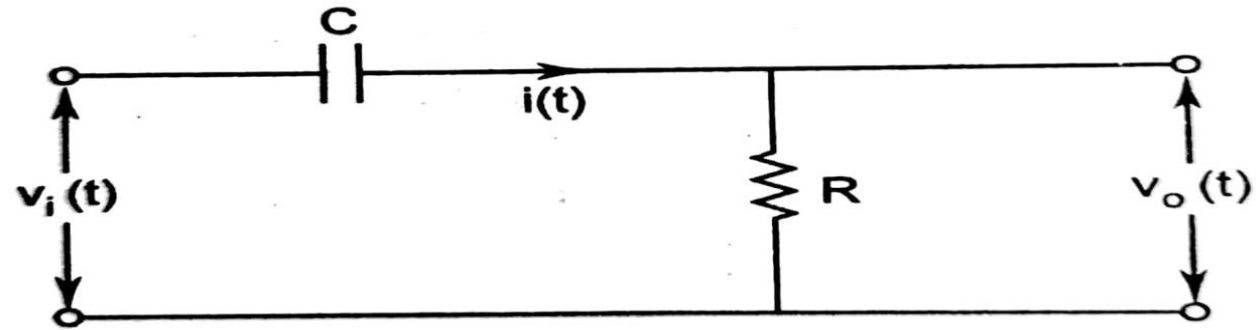

$$v_i(t) = Ri(t) + \frac{1}{C} \int i(t) dt$$

$$v_o(t) = Ri(t)$$

Laplace
Transform

$$V_i(s) = RI(s) + \frac{1}{Cs} I(s)$$

$$V_o(s) = RI(s)$$

$$\frac{V_o(s)}{V_i(s)} = \frac{R}{R + \frac{1}{Cs}}$$

$\frac{V_o(s)}{V_i(s)}$ is known as transfer function



- Example 2: Determine $V_o(s)/V_i(s)$ of the following circuit.

$$v_i(t) = R_1 i(t) + R_2 i(t) + \frac{1}{C} \int i(t) dt$$

$$v_o(t) = R_2 i(t) + \frac{1}{C} \int i(t) dt$$

$$\frac{V_o(s)}{V_i(s)} = \frac{R_2 + \frac{1}{Cs}}{R_1 + R_2 + \frac{1}{Cs}}$$

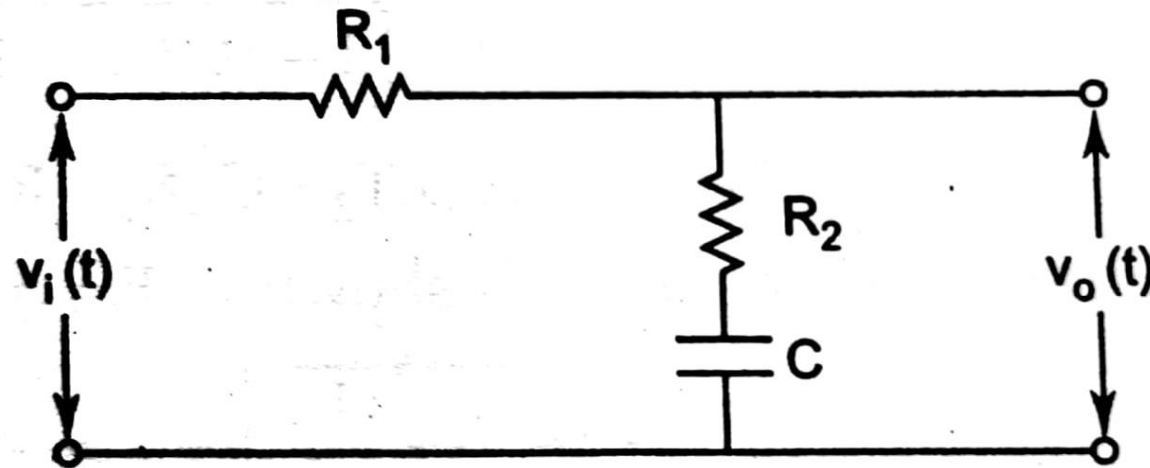



Why Laplace Transform?

- Using Laplace transform, we can convert many common functions into algebraic function of complex variable s .

- For example

$$\ell \sin \omega t = \frac{\omega}{s^2 + \omega^2}$$

$$\ell e^{-at} = \frac{1}{s + a}$$

- Where s is a complex variable (complex frequency) and is given as

$$s = \sigma + j\omega$$



LAPLACE TRANSFORM OF DERIVATIVES



- Not only common function can be converted into simple algebraic expressions but calculus operations can also be converted into algebraic expressions.
- For example

$$\ell \frac{dx(t)}{dt} = sX(s) - x(0)$$

$$\ell \frac{d^2x(t)}{dt^2} = s^2X(s) - s \cdot x(0) - \frac{dx(0)}{dt}$$



LAPLACE TRANSFORM OF DERIVATIVES



- In general
$$\ell \frac{d^n x(t)}{dt^n} = s^n X(s) - \sum_{k=1}^n s^{n-k} x^{(k-1)}(0)$$

Laplace Transform of Integrals

$$\ell \int x(t) dt = \frac{1}{s} X(s)$$

- The time domain integral becomes division by **s** in frequency domain.



CALCULATION OF THE TRANSFER FUNCTION



- Consider the following ODE where $y(t)$ is input of the system and $x(t)$ is the output.

$$A \frac{d^2 x(t)}{dt^2} = C \frac{dy(t)}{dt} - B \frac{dx(t)}{dt}$$

- or

$$Ax''(t) = Cy'(t) - Bx'(t)$$

- Taking the Laplace transform on either sides

$$A[s^2 X(s) - sx(0) - x'(0)] = C[sY(s) - y(0)] - B[sX(s) - x(0)]$$



CALCULATION OF THE TRANSFER FUNCTION



$$A[s^2 X(s) - sx(0) - x'(0)] = C[sY(s) - y(0)] - B[sX(s) - x(0)]$$

- Considering Initial conditions to zero in order to find the transfer function of the system

$$As^2 X(s) = CsY(s) - BsX(s)$$

- Rearranging the above equation

$$As^2 X(s) + BsX(s) = CsY(s)$$

$$X(s)[As^2 + Bs] = CsY(s)$$

$$\frac{X(s)}{Y(s)} = \frac{Cs}{As^2 + Bs} = \frac{C}{As + B}$$



ACTIVITY

TELL ABOUT YOUR SELF....

I graduated with my degree in ECE two months ago. I chose that field of study because I've always been interested in ECE, and a couple of family members told me it leads to great career options, too."



1. Choose the Right Starting Point for Your Story (IMPORTANT)
2. Highlight Impressive Experience and Accomplishments
3. Conclude by Explaining Your Current Situation
4. Keep Your Answer Work-Related
5. Be Concise When Answering (2 Minutes or Less!)



TRANSFER FUNCTION



- In general

$$\begin{aligned} a_0 y^{(n)} + a_1 y^{(n-1)} + \cdots + a_{n-1} \dot{y} + a_n y \\ = b_0 x^{(m)} + b_1 x^{(m-1)} + \cdots + b_{m-1} \dot{x} + b_m x \quad (n \geq m) \end{aligned}$$

- Where x is the input of the system and y is the output of the system.

$$\begin{aligned} \text{Transfer function} = G(s) &= \frac{\mathcal{L}[\text{output}]}{\mathcal{L}[\text{input}]} \Bigg|_{\text{zero initial conditions}} \\ &= \frac{Y(s)}{X(s)} = \frac{b_0 s^m + b_1 s^{m-1} + \cdots + b_{m-1} s + b_m}{a_0 s^n + a_1 s^{n-1} + \cdots + a_{n-1} s + a_n} \end{aligned}$$



Transfer Function



$$\frac{Y(s)}{X(s)} = \frac{b_0s^m + b_1s^{m-1} + \dots + b_{m-1}s + b_m}{a_0s^n + a_1s^{n-1} + \dots + a_{n-1}s + a_n} \quad (n \geq m)$$

- When order of the denominator polynomial is greater than the numerator polynomial the transfer function is said to be **'proper'**.
- Otherwise **'improper'**



APPLICATIONS OF TRANSFER FUNCTION



- Transfer function can be used to check
 - The stability of the system
 - Time domain and frequency domain characteristics of the system
 - Response of the system for any given input



STABILITY OF CONTROL SYSTEM



- There are several meanings of stability, in general there are two kinds of stability definitions in control system study.
 - Absolute Stability
 - Relative Stability



STABILITY OF CONTROL SYSTEM



$$\frac{Y(s)}{X(s)} = \frac{b_0s^m + b_1s^{m-1} + \dots + b_{m-1}s + b_m}{a_0s^n + a_1s^{n-1} + \dots + a_{n-1}s + a_n}$$

- Roots of denominator polynomial of a transfer function are called 'poles'.
- The roots of numerator polynomials of a transfer function are called 'zeros'.



STABILITY OF CONTROL SYSTEM



- Poles of the system are represented by 'x' and zeros of the system are represented by 'o'.
- System order is always equal to number of poles of the transfer function.
- Following transfer function represents n^{th} order plant (i.e., any physical object).

$$\frac{Y(s)}{X(s)} = \frac{b_0s^m + b_1s^{m-1} + \dots + b_{m-1}s + b_m}{a_0s^n + a_1s^{n-1} + \dots + a_{n-1}s + a_n}$$



STABILITY OF CONTROL SYSTEM



- Poles is also defined as “it is the frequency at which system becomes infinite”. Hence the name pole where field is infinite.

$$\frac{Y(s)}{X(s)} = \frac{b_0s^m + b_1s^{m-1} + \dots + b_{m-1}s + b_m}{a_0s^n + a_1s^{n-1} + \dots + a_{n-1}s + a_n}$$

- Zero is the frequency at which system becomes 0.



STABILITY OF CONTROL SYSTEM



- Poles is also defined as “it is the frequency at which system becomes infinite”.
- Like a magnetic pole or black hole.

$$\frac{Y(s)}{X(s)} = \frac{b_0s^m + b_1s^{m-1} + \dots + b_{m-1}s + b_m}{a_0s^n + a_1s^{n-1} + \dots + a_{n-1}s + a_n}$$

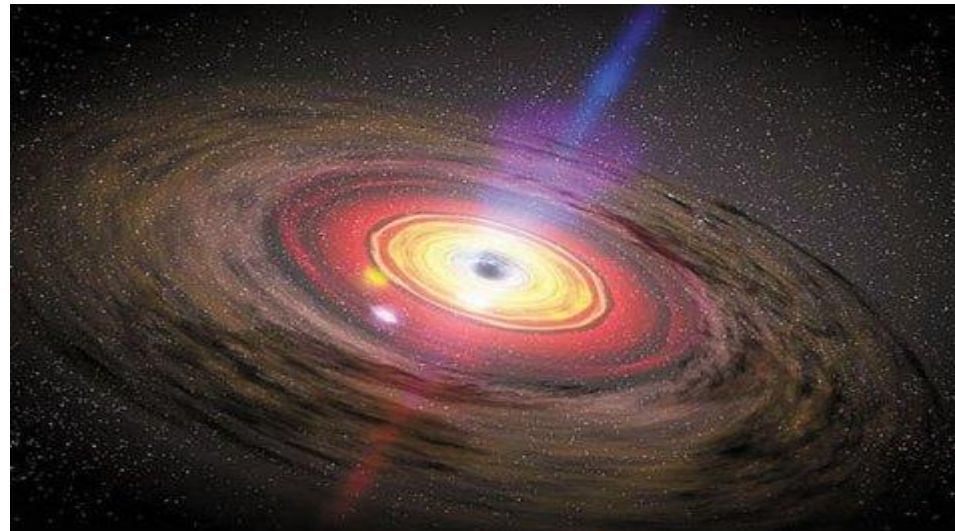



RELATION B/W POLES & ZEROS AND FREQUENCY RESPONSE OF THE SYSTEM

- The relationship between poles and zeros and the frequency response of a system comes alive with this 3D pole-zero plot.

Single pole system

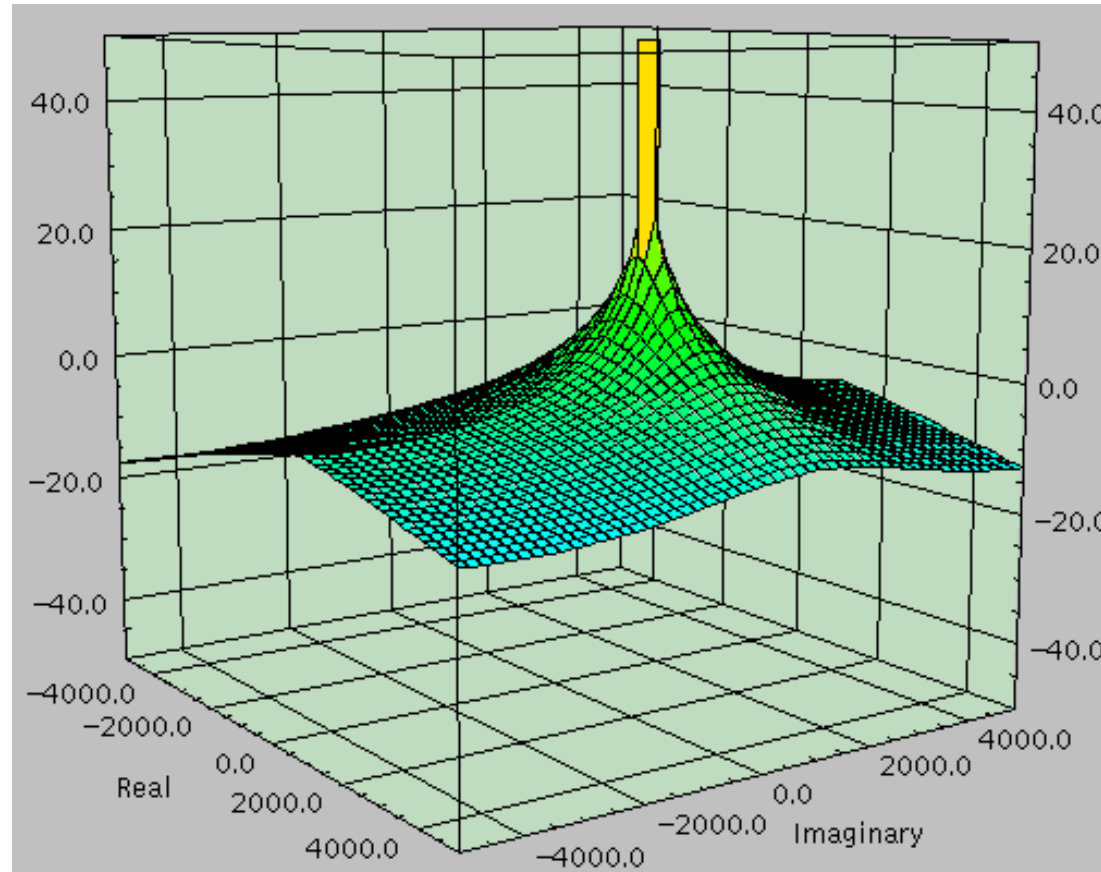



EXAMPLE



- Consider the Transfer function calculated in previous slides.

$$G(s) = \frac{X(s)}{Y(s)} = \frac{C}{As + B}$$

the denominator polynomial is $As + B = 0$

- The only pole of the system is

$$s = -\frac{B}{A}$$



EXAMPLES



- Consider the following transfer functions.
 - Determine
 - Whether the transfer function is proper or improper
 - Poles of the system
 - zeros of the system
 - Order of the system

$$G(s) = \frac{s + 3}{s(s + 2)}$$

$$G(s) = \frac{s}{(s + 1)(s + 2)(s + 3)}$$

$$G(s) = \frac{(s + 3)^2}{s(s^2 + 10)}$$

$$G(s) = \frac{s^2(s + 1)}{s(s + 10)}$$



STABILITY OF CONTROL SYSTEMS



- The poles and zeros of the system are plotted in **s-plane** to check the stability of the system.

Recall $s = \sigma + j\omega$

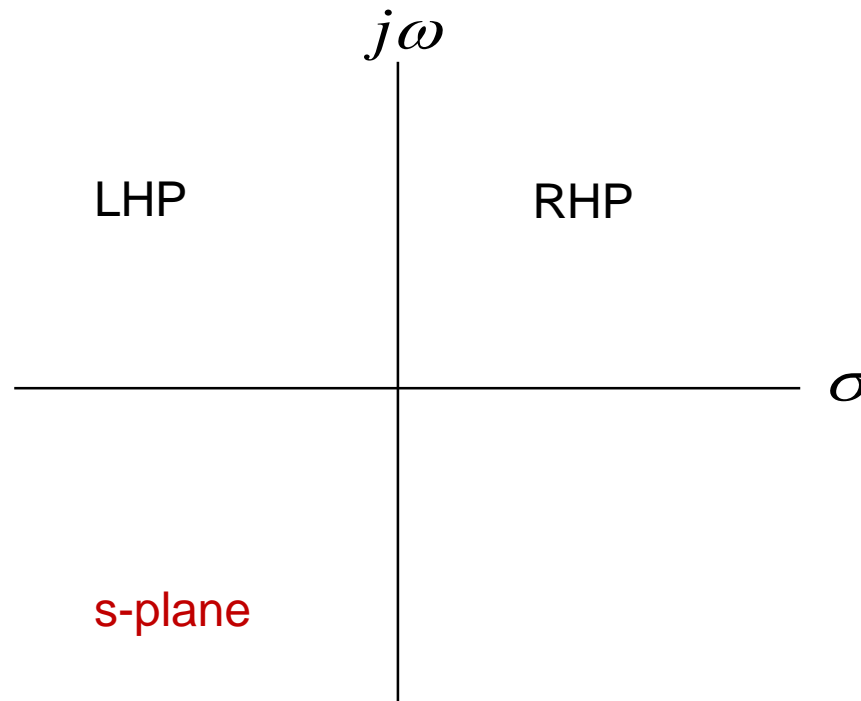



STABILITY OF CONTROL SYSTEMS



- If all the poles of the system lie in left half plane the system is said to be **Stable**.
- If any of the poles lie in right half plane the system is said to be **unstable**.
- If pole(s) lie on imaginary axis the system is said to be **marginally stable**.

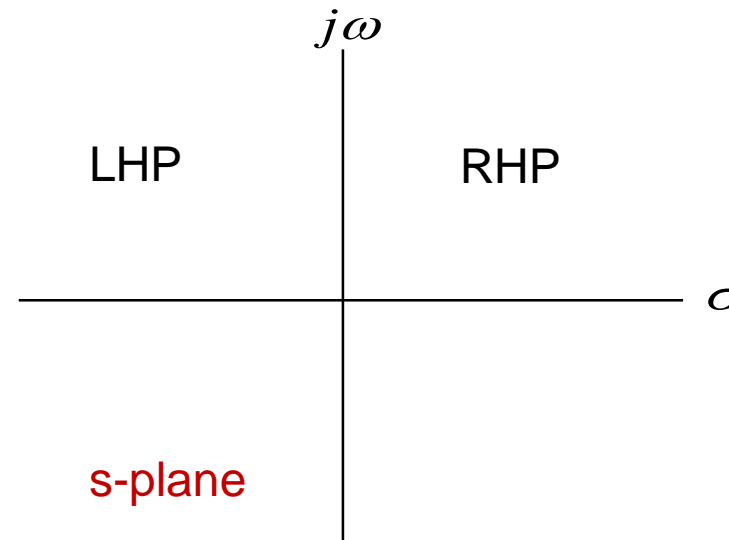



STABILITY OF CONTROL SYSTEMS



- For example

$$G(s) = \frac{C}{As + B}, \quad \text{if } A = 1, B = 3 \text{ and } C = 10$$

- Then the only pole of the system lie at

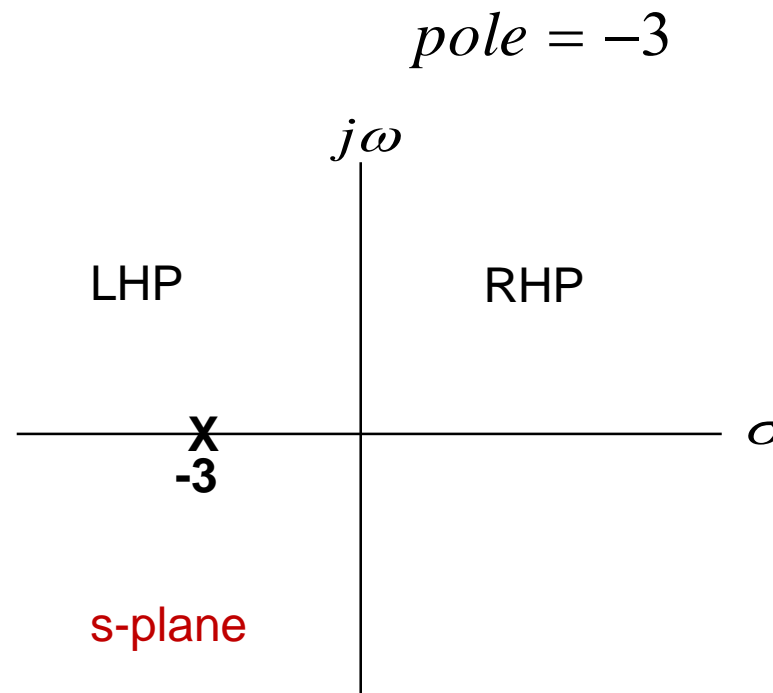



THE OTHER DEFINITION OF STABILITY



- The system is said to be stable if for any bounded input the output of the system is also bounded (BIBO).
- Thus for any bounded input the output either remain constant or decrease with time.

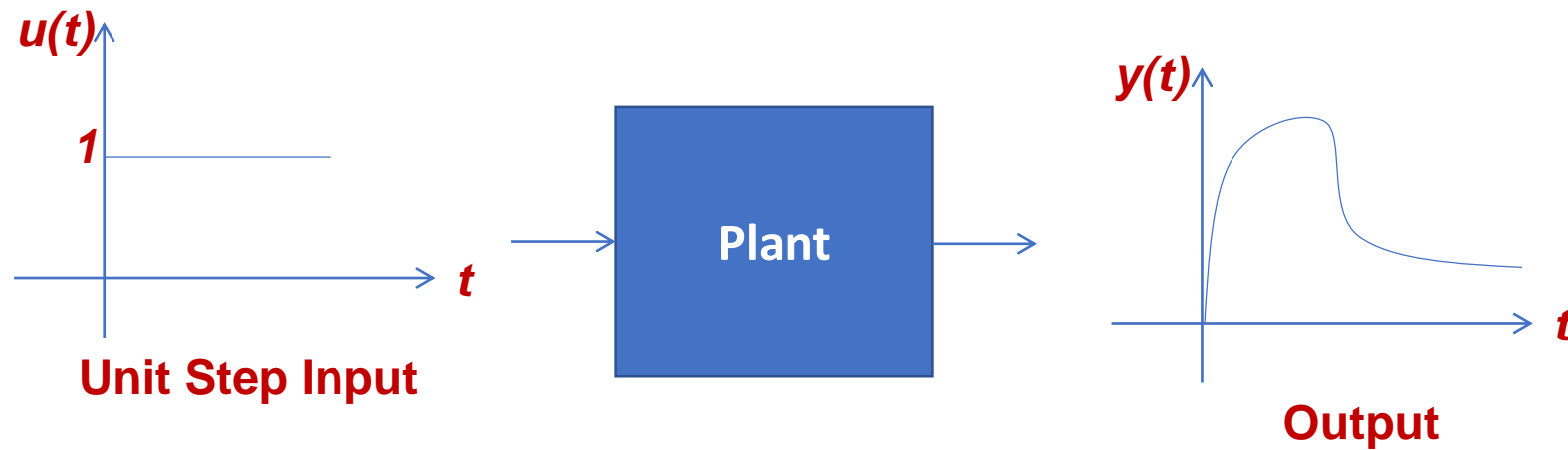



THE OTHER DEFINITION OF STABILITY



- If for any bounded input the output is not bounded the system is said to be unstable.

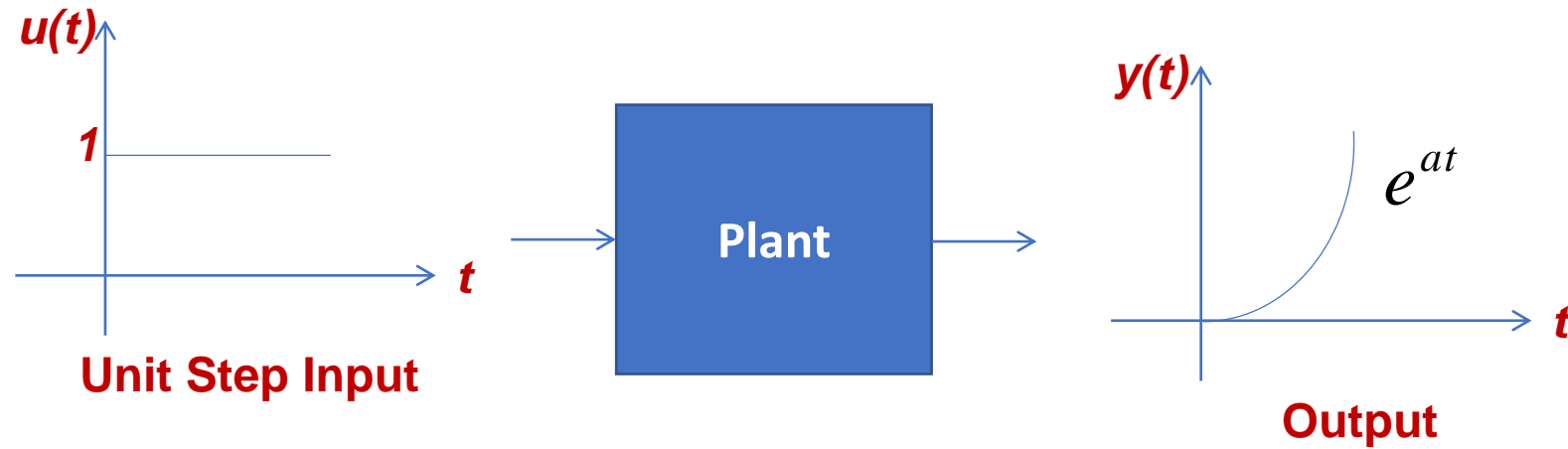



POLES AND ZEROS



- Let a transfer function is given as

- $$G(s) = \frac{7(s+2)(s+4)}{s(s+3)(s+5)(s+2-j4)(s+2+j4)}$$

- Poles: $s = 0, -3, -5, -2+j4, -2-j4$ (5 poles)

- Zeros: $s = -2, -4$ (2 zeros)

- 7 is known as gain factor denoted by K.



POLES AND ZEROS ...



■ Note:

- If poles and zeros are complex, they will be in conjugate
- No of poles = No of zeros
- In the above example, three zeros are at $s = \infty$
- Transient behavior depends on poles and zeros
- Poles + Zeros + Gain Constant (K) completely define a system (differential equation)

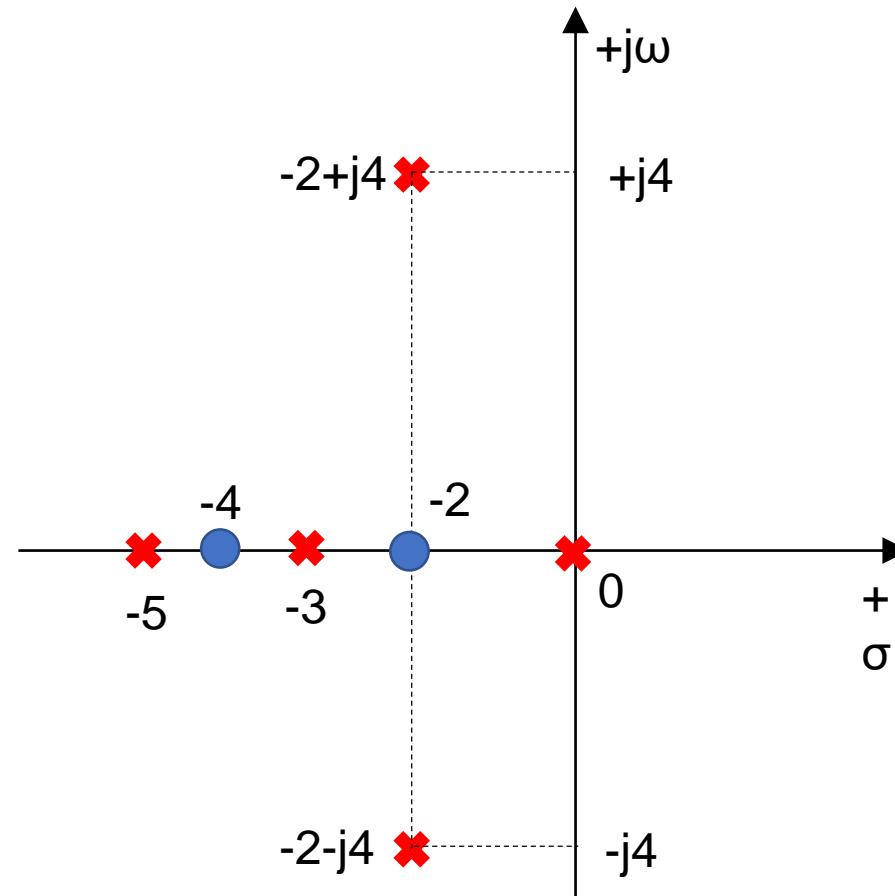

Pole-Zero Diagram



SUMMARY

- Transfer Function
- The Order of Control Systems
- Poles, Zeros
- Stability
- BIBO

