



SNS COLLEGE OF TECHNOLOGY



(An Autonomous Institution)

COIMBATORE-35

Accredited by NBA-AICTE and Accredited by NAAC – UGC with A++ Grade

Approved by AICTE, New Delhi & Affiliated to Anna University, Chennai

UNIT III: SPEED GOVERNING AND AUTOMATIC GENERATION

TOPIC: **TYPES OF RESERVES**

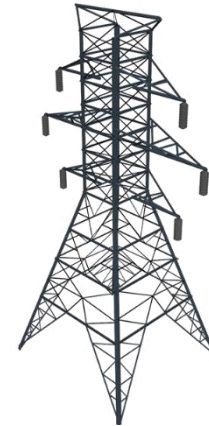



TOPIC OUTLINE

- INTRODUCTION
- TYPES RESERVES
- COLD RESERVE
- HOT RESERVE
- SPINNING RESERVE
- LOAD FREQUENCY CONTROL



Introduction



Power System nowadays is one of the most complex system. There are a number of generating stations that generate power equal to load at that particular time.

However, if need arises, the system can generate more power. This ability of power system to generate power over and above the current demand is expressed as reserve capacity.

Accordingly two important terms Hot and Cold Reserve Capacity comes into picture.



Cold Reserve Capacity



Cold Reserve Capacity:

Cold reserve in a power system is that reserve capacity which is available for service but normally not ready for immediate loading. A Cold reserve is ensured by special reserve units with small start-up and spin-up time.

Period of the cold reserve start-up is varies from 2 to 24 hours and more. Units with small start-up time usually have a power-on reserve.

For example, we have an idle generator that can be taken into service if demand increases.



Hot Reserve Capacity



Hot Reserve Capacity:

Hot Reserve in a power system is that reserve capacity which can be made available quickly. For example, we have a hydroelectric generator of rating say 100 MVA but currently supplies only 70 MVA.

In this case we have 30 MVA hot reserve than can be loaded immediately by simply opening the valve to the hydro turbine.

Spinning Reserve Capacity

Spinning Reserve Capacity:

Spinning Reserve of active capacity is capacity reserve located at operating units and units with the start-up time of up to 5 minutes. Thus, a fast-start reserve is also a Spinning Reserve.



Load frequency control

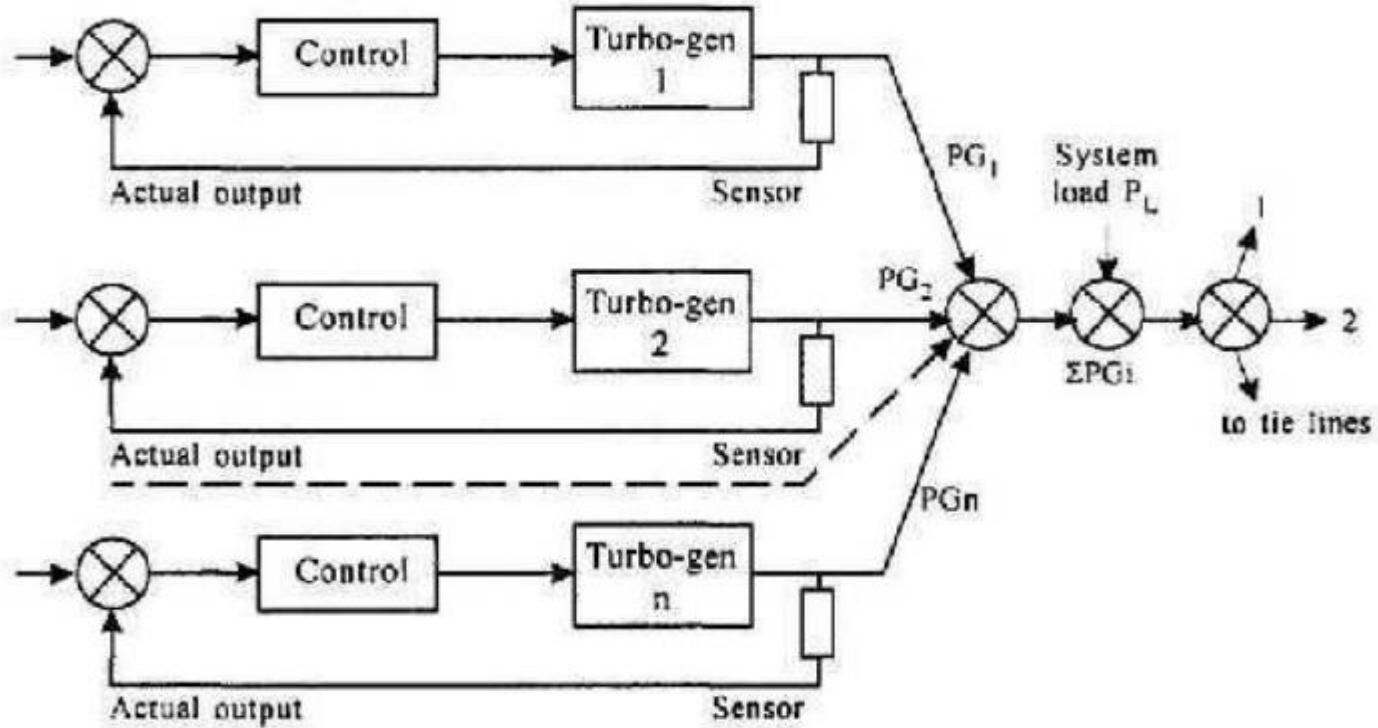



LOAD FREQUENCY CONTROL

The following basic requirements are to be fulfilled for successful operation of the system:

1. The generation must be adequate to meet all the load demand
2. The system frequency must be maintained within narrow and rigid limits.
3. The system voltage profile must be maintained within reasonable limits
4. In case of interconnected operation, the tie line power flows must be maintained at the specified values.



Load frequency control



Control area: Most power systems normally control their generators in unison. The individual control loops have the same regulation parameters. The individual generator turbines tend to have the same response characteristics then it is possible to let the control loop in the whole system which then would be referred to as a control area.

Power Pool: An association of two or more interconnected electric systems having an agreement to coordinate operations and planning for improved reliability and efficiencies.



RECAP...

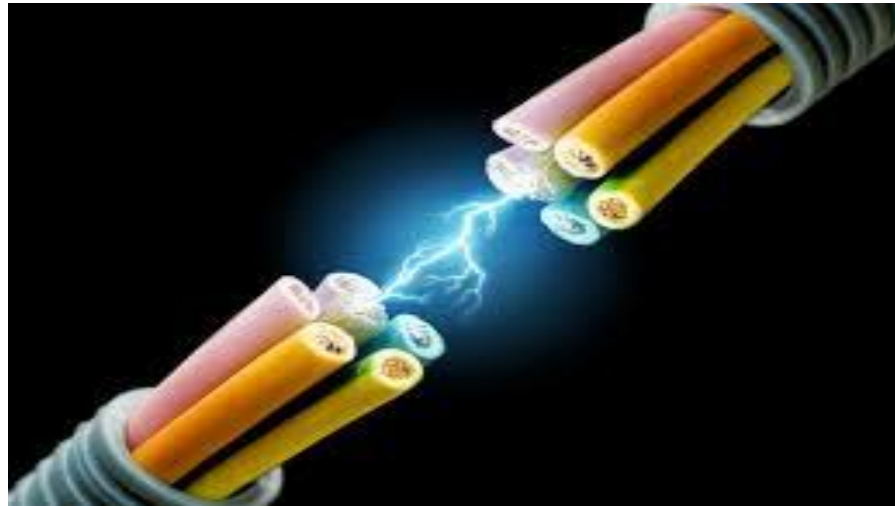

...THANK YOU

