



SNS COLLEGE OF TECHNOLOGY

Coimbatore-35.

An Autonomous Institution



**Accredited by NBA – AICTE and Accredited by NAAC – UGC with ‘A+’ Grade
Approved by AICTE, New Delhi & Affiliated to Anna University, Chennai**

COURSE NAME : 23CST202 – OPERATING SYSTEMS

II YEAR/ IV SEMESTER

UNIT – I OVERVIEW AND PROCESS MANAGEMENT

Topic: Process Scheduling

Dr.V.Savitha

Associate Professor

Department of Computer Science and Engineering



Process Scheduling



- Maximize CPU use, quickly switch processes onto CPU for time sharing
- **Process scheduler** selects among available processes for next execution on CPU
- Maintains **scheduling queues** of processes
 - **Job queue** – set of all processes in the system
 - **Ready queue** – set of all processes residing in main memory, ready and waiting to execute
 - **Device queues** – set of processes waiting for an I/O device
 - Processes migrate among the various queues



Ready Queue And Various I/O Device Queues

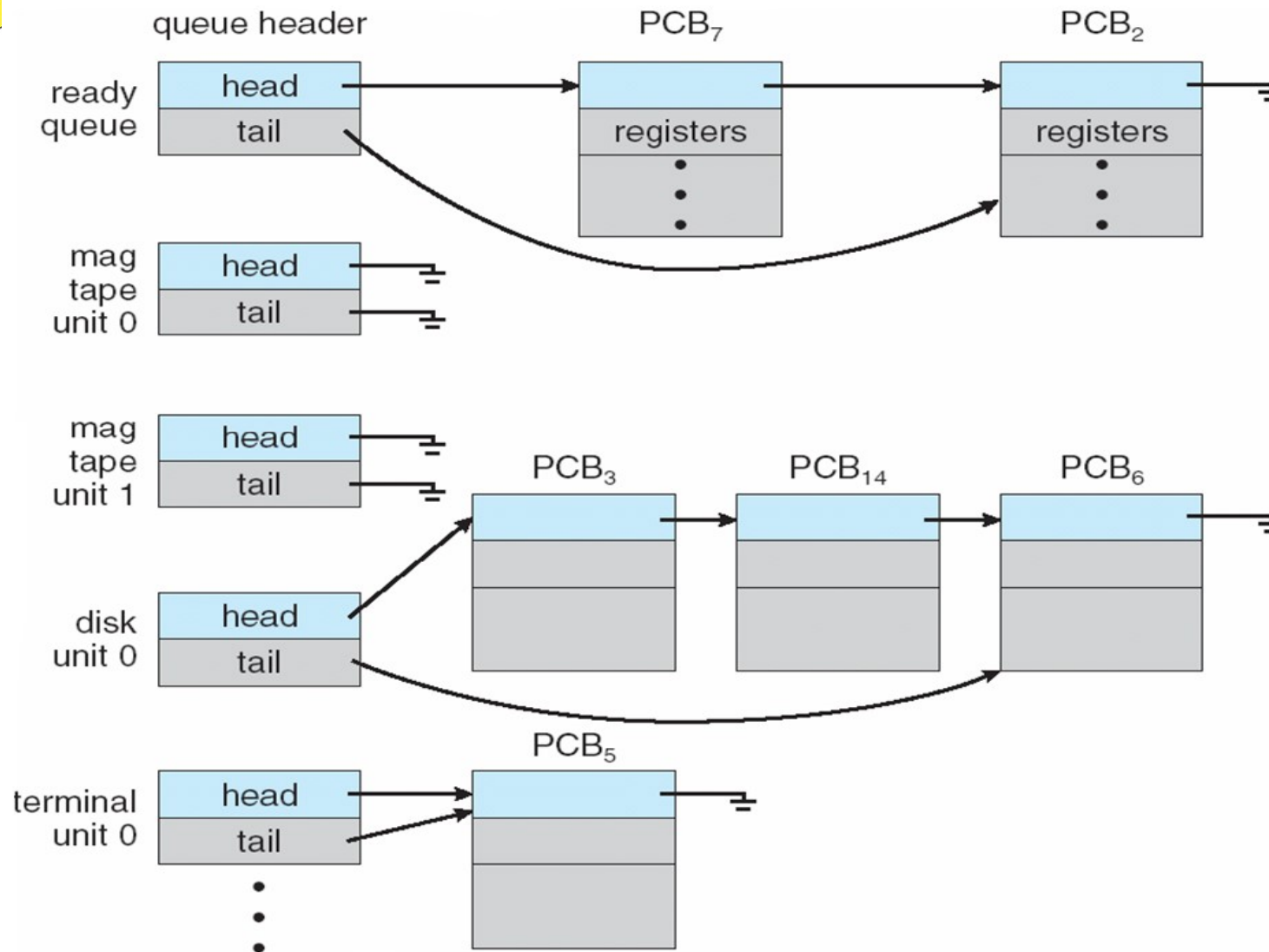



Representation of Process Scheduling



- **Queueing diagram** represents queues, resources, flows

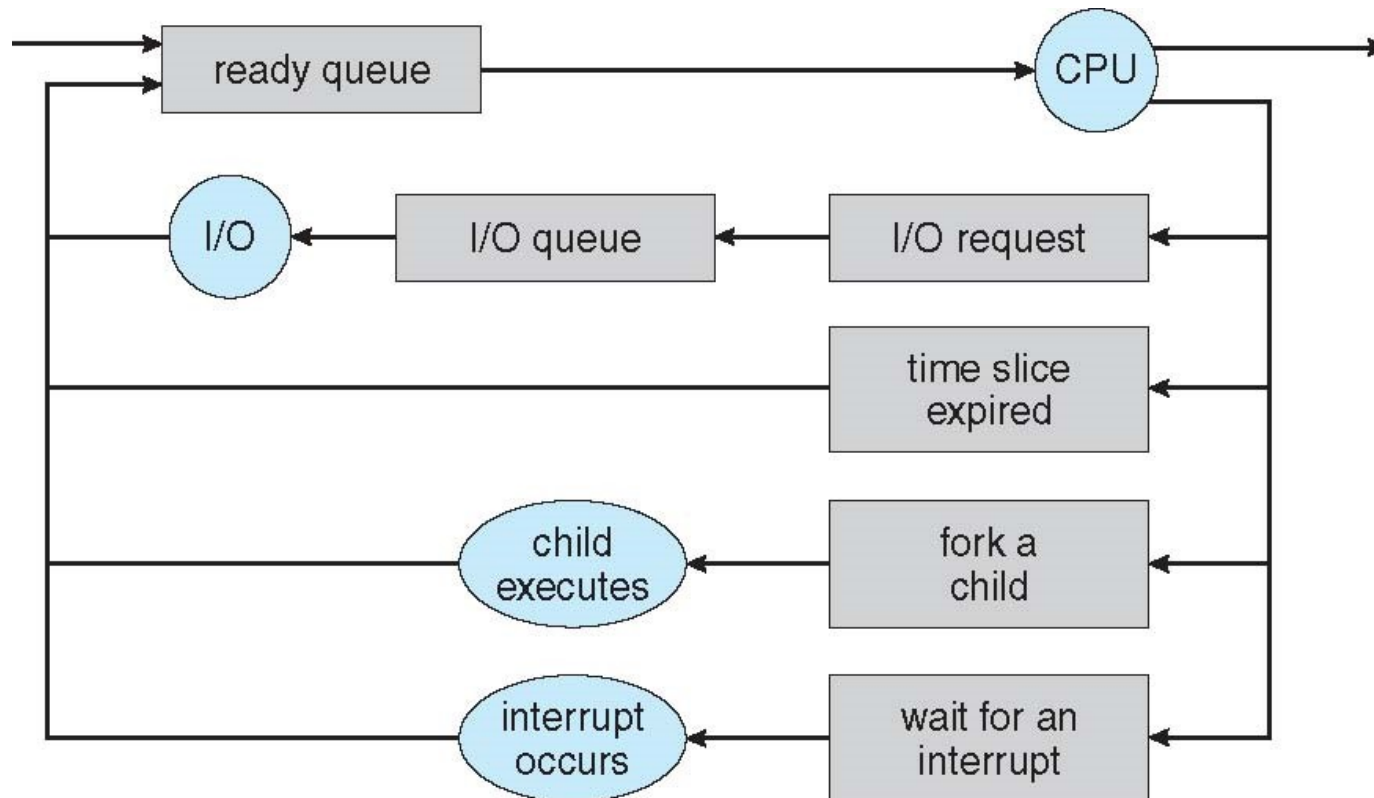



Schedulers



- **Short-term scheduler** (or **CPU scheduler**) – selects which process should be executed next and allocates CPU
 - Sometimes the only scheduler in a system
 - Short-term scheduler is invoked frequently (milliseconds) \Rightarrow (must be fast)
- **Long-term scheduler** (or **job scheduler**) – selects which processes should be brought into the ready queue
 - Long-term scheduler is invoked infrequently (seconds, minutes) \Rightarrow (may be slow)
 - The long-term scheduler controls the **degree of multiprogramming**
- Processes can be described as either:
 - **I/O-bound process** – spends more time doing I/O than computations, many short CPU bursts
 - **CPU-bound process** – spends more time doing computations; few very long CPU bursts
- Long-term scheduler strives for good ***process mix***



Addition of Medium Term Scheduling



- **Medium-term scheduler** can be added if degree of multiple programming needs to decrease
 - Remove process from memory, store on disk, bring back in from disk to continue execution: **swapping**

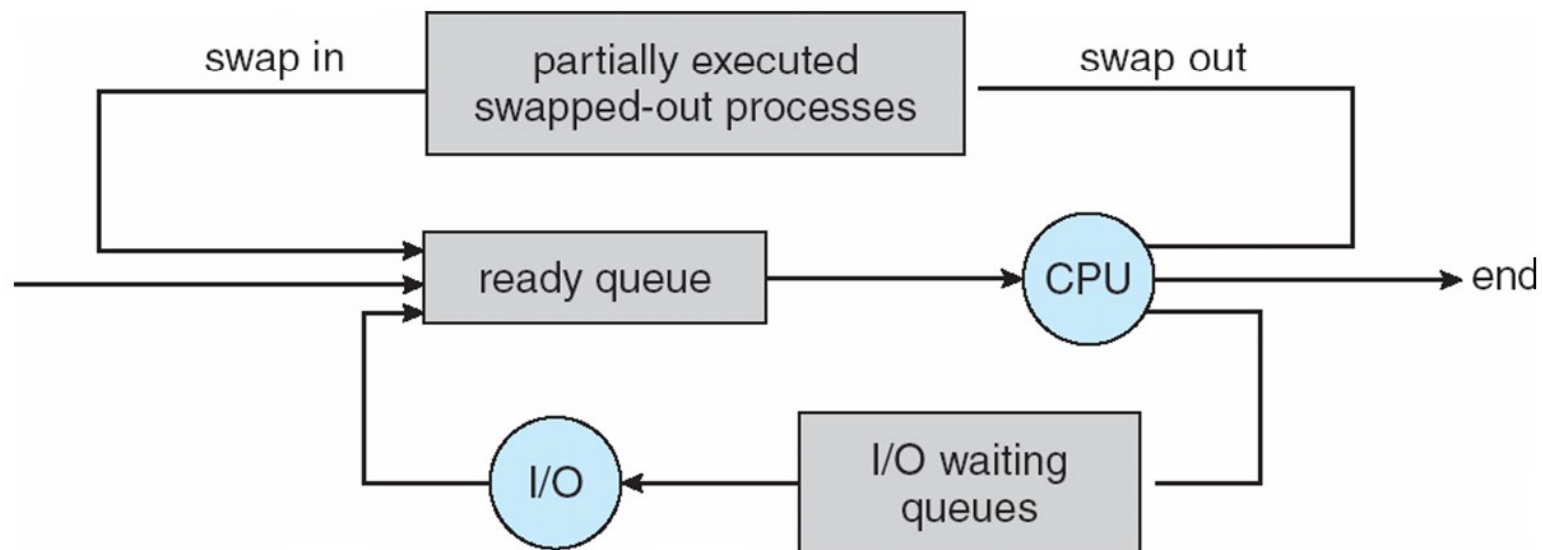



Context Switch



- When CPU switches to another process, the system must **save the state** of the old process and load the **saved state** for the new process via a **context switch**
- **Context** of a process represented in the PCB
- Context-switch time is overhead; the system does no useful work while switching
 - The more complex the OS and the PCB → the longer the context switch
- Time dependent on hardware support
 - Some hardware provides multiple sets of registers per CPU → multiple contexts loaded at once



REFERENCES



TEXT BOOKS:

- T1 Silberschatz, Galvin, and Gagne, “Operating System Concepts”, Ninth Edition, Wiley India Pvt Ltd, 2009.)
- T2. Andrew S. Tanenbaum, “Modern Operating Systems”, Fourth Edition, Pearson Education, 2010

REFERENCES:

- R1 Gary Nutt, “Operating Systems”, Third Edition, Pearson Education, 2004.
- R2 Harvey M. Deitel, “Operating Systems”, Third Edition, Pearson Education, 2004.
- R3 Abraham Silberschatz, Peter Baer Galvin and Greg Gagne, “Operating System Concepts”, 9th Edition, John Wiley and Sons Inc., 2012.
- R4. William Stallings, “Operating Systems – Internals and Design Principles”, 7th Edition, Prentice Hall, 2011