



# **SNS COLLEGE OF TECHNOLOGY**

**Coimbatore-35**  
**An Autonomous Institution**



Accredited by NBA – AICTE and Accredited by NAAC – UGC with 'A++' Grade  
Approved by AICTE, New Delhi & Affiliated to Anna University, Chennai

## **DEPARTMENT OF ELECTRONICS & COMMUNICATION ENGINEERING**

### **23ECB202 – LINEAR INTEGRATED CIRCUITS**

II YEAR/ III SEMESTER  
1

#### **UNIT 1 – OPAMP CHARACTERISTICS**

#### **TOPIC 1- 2 – Internal circuit diagram of IC 741**



# Internal circuit diagram of IC 741

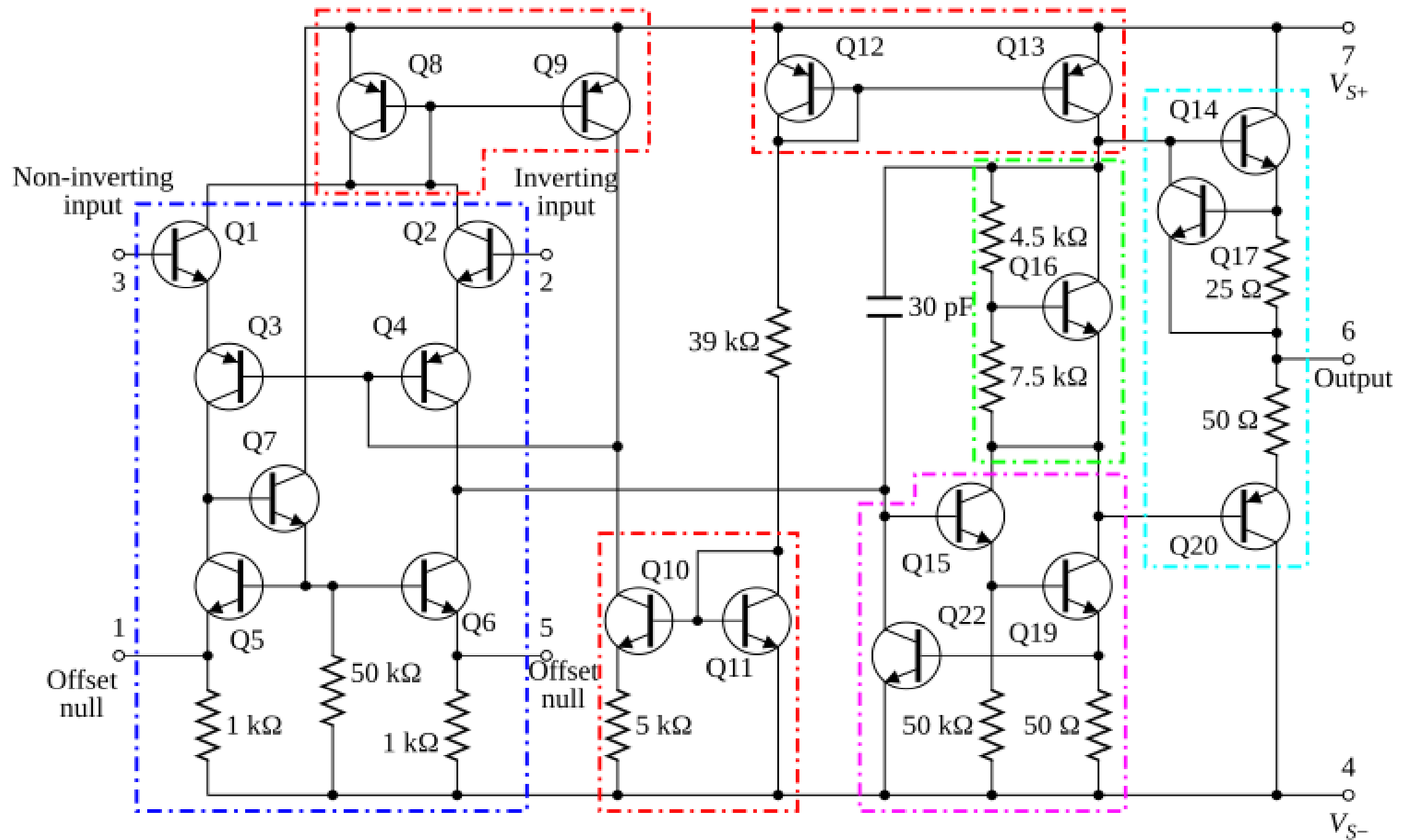



# Internal circuit diagram of IC 741



**Internal Circuitry:** The IC 741 contains 20 transistors and 11 resistors, and other components integrated into a single chip. Its internal circuitry consists of several stages, including differential amplifier stage, gain stage, output stage, and compensation network.

**Differential Amplifier Stage:** The input stage of the 741 consists of a differential amplifier. This stage amplifies the voltage difference between its two input terminals (inverting and non-inverting). The gain of this stage is typically very high, providing high input impedance and low output impedance.

**Gain Stage:** The amplified voltage from the input stage is then further amplified by the gain stage. The 741 has a high open-loop voltage gain, typically around 100,000. This gain can be adjusted using external feedback components like resistors.

**Output Stage:** The output stage of the 741 is designed to provide a high output current capability while maintaining a low output impedance. It also ensures compatibility with various loads.

**Compensation Network:** The 741 incorporates internal compensation to stabilize its operation and prevent oscillations. This compensation network typically consists of capacitors and resistors.

**Power Supply:** The IC 741 requires dual power supplies (positive and negative) for its operation. These power supplies typically range from  $\pm 5V$  to  $\pm 15V$ .



# Internal circuit diagram of IC 741



- 1. Input Stage with Transistors Q1 and Q2:** These transistors serve as the input stage of the op-amp, with Q1 connected to the inverting terminal and Q2 connected to the non-inverting terminal. This configuration helps to isolate the input signals and prevent feedback
- 2. Current Mirrors (Q8/Q9 and Q12/Q13):** These circuits regulate the current flow within the op-amp, ensuring stable operation and minimizing the impact of input voltage fluctuations on internal circuitry
- 3. Voltage Level Shifter (Q16):** This circuit reduces the voltage level from the amplifier circuit at the input section before passing it to the next stage. This helps prevent signal distortion
- 4. Class A Amplifier Stage (Q15, Q19, Q22) and Output Stage (Q14, Q17, Q20):** These stages are responsible for amplifying the input signal and driving the output with sufficient power. The class A amplifier stage ensures linear amplification with minimal distortion
- 5. Offset Null Configuration (Q5, Q6, Q7):** These transistors are part of a configuration that allows for offset null adjustment, balancing both the inverting and non-inverting inputs to minimize any irregularities at the input phase of the differential circuit.



**THANK YOU**