



SNS COLLEGE OF TECHNOLOGY

Coimbatore-35
An Autonomous Institution



Accredited by NBA – AICTE and Accredited by NAAC – UGC with 'A++' Grade
Approved by AICTE, New Delhi & Affiliated to Anna University, Chennai

DEPARTMENT OF ELECTRONICS & COMMUNICATION ENGINEERING

23ECB202 – LINEAR INTEGRATED CIRCUITS

II YEAR/ III SEMESTER
1

UNIT 1 – OP AMP CHARACTERISTICS

TOPIC 1- 5 DC characteristics of Op Amp



Why DC Characteristics?



- An ideal op- amp draws no current from the source and its response is also independent of temperature
- An real op-amp does not work this way
- Current is taken from the source into the op-amp inputs
- Also the inputs respond differently to current and voltage due to mismatch in transistors
- A real op-amp also shifts its operation with temperature
- In this case, these non- ideal dc characteristics that add error components to the dc output voltage



DC Characteristics



1. Input bias current
2. Input offset current
3. Input offset voltage
4. Thermal drift

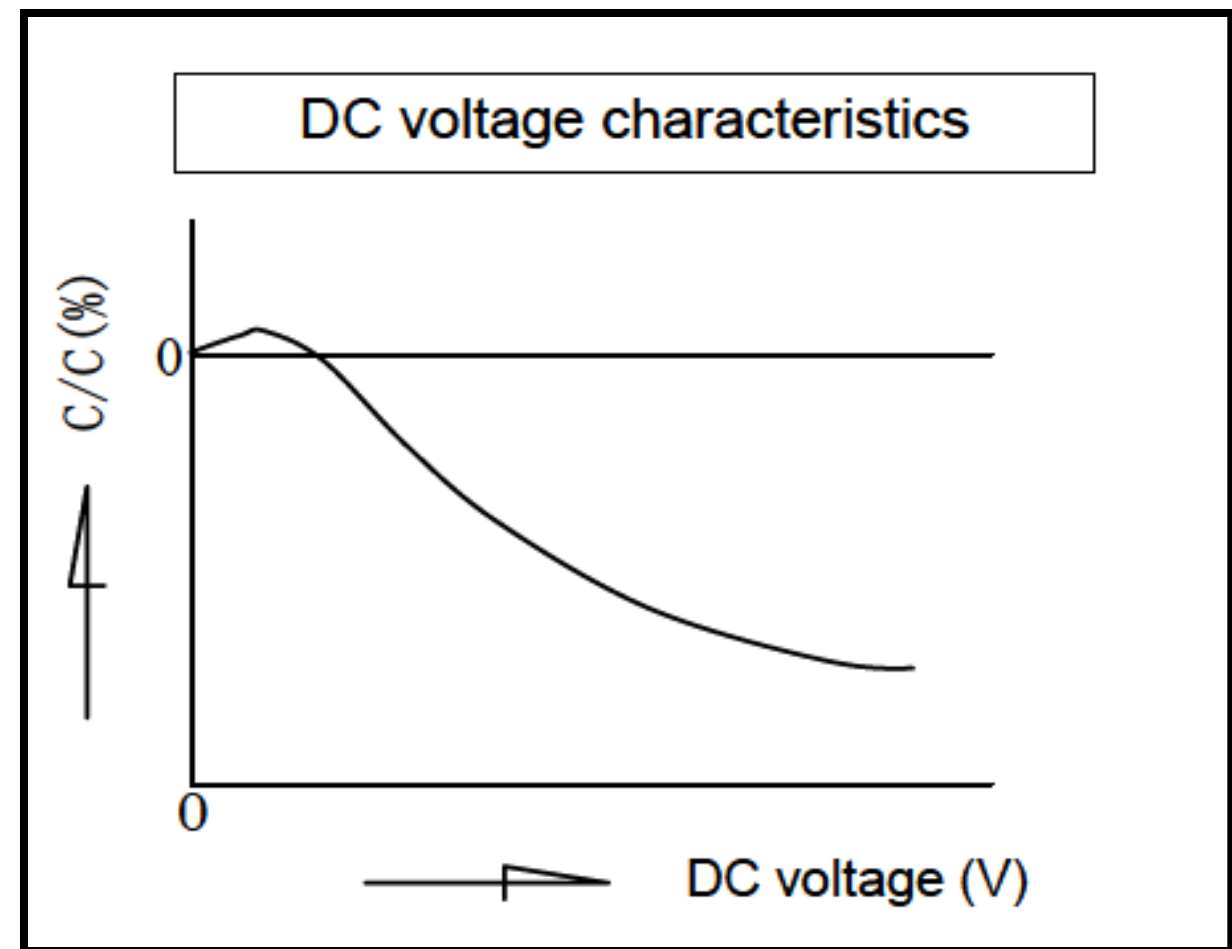



Input bias current



- The op-amp's input is differential amplifier, which may be made of BJT or FET. In an ideal op-amp, we assumed that no current is drawn from the input terminals the base currents entering into the inverting and non-inverting terminals (I_{B-} & I_{B+} respectively)
- Even though both the transistors are identical, I_{B-} and I_{B+} are not exactly equal due to internal imbalance between the two inputs
- Input bias current and Inverting amplifier with bias currents



Input bias current

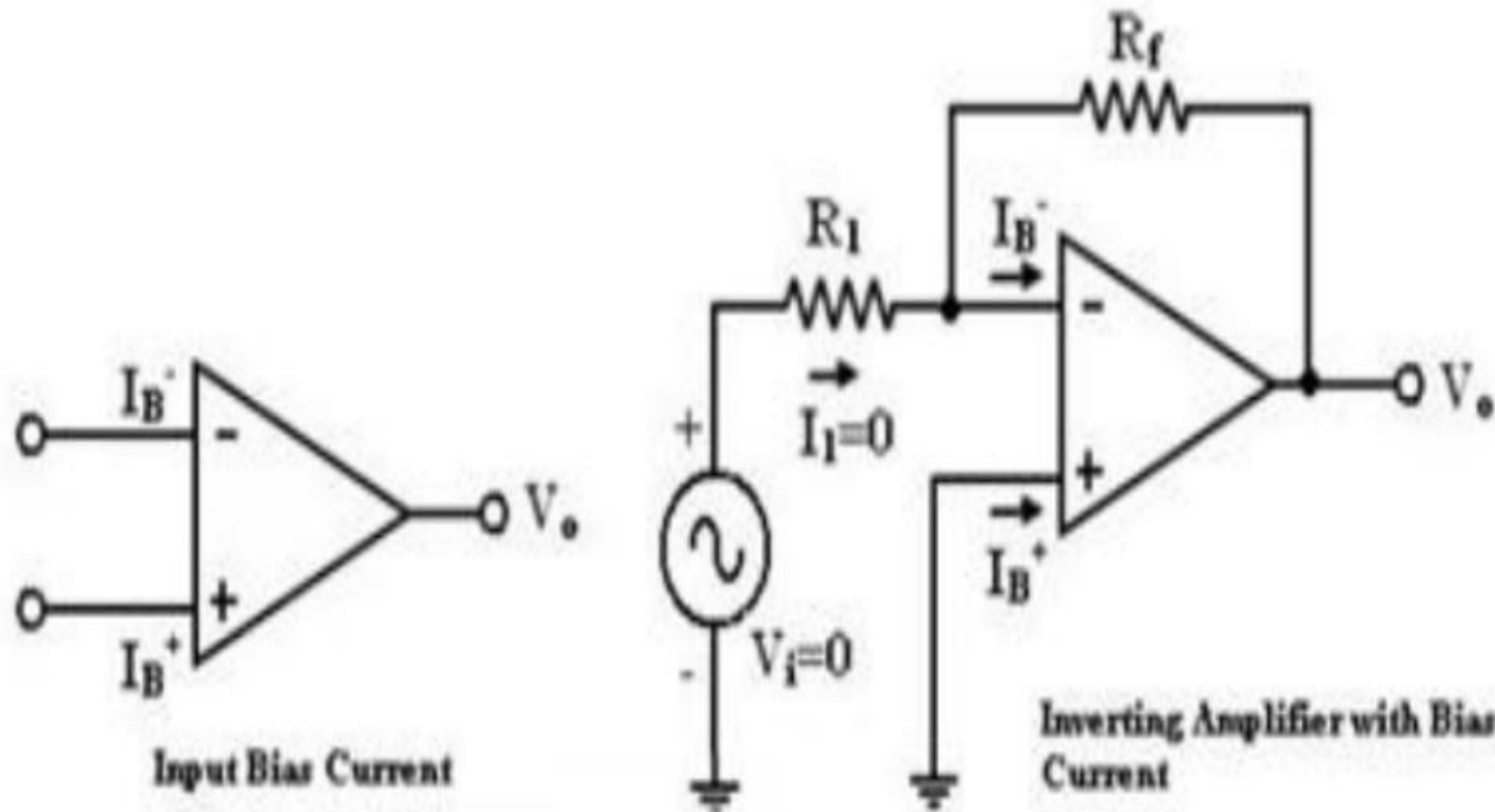

$$I_B = \frac{I_{b1} + I_{b2}}{2}$$



Input bias current



- In application where the signal levels are measured in mV, this is totally unacceptable
- This can be compensated by a compensation resistor R_{comp} has been added between the non-inverting input terminal and ground

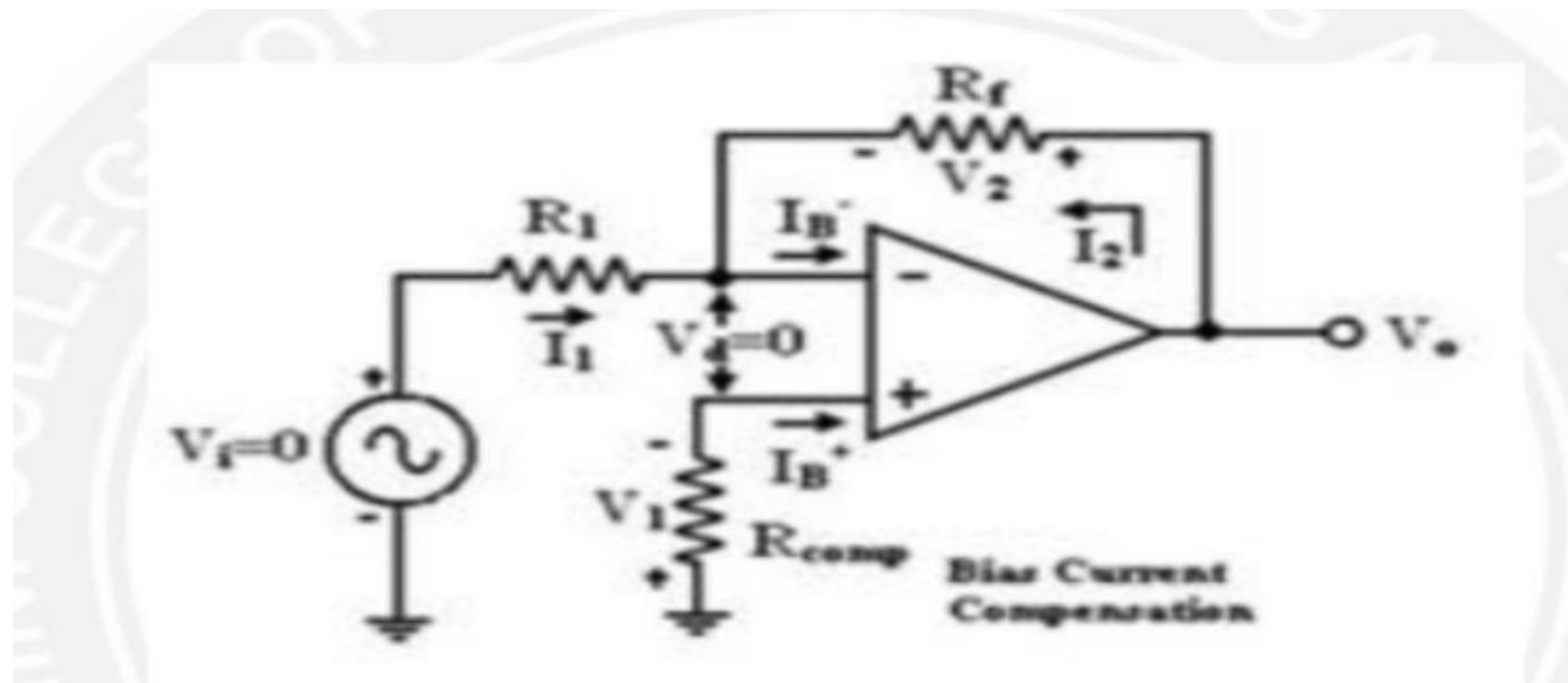



Input offset current



- The input stage of the op-amp is dual input differential amplifier
- Hence the input currents of op-amp are the base currents of the transistors used in the input stage
- Due to transistor mismatch these currents differ
- The algebraic difference between the currents flowing into the two input terminals of the op-amp is called input offset current and denoted as I_{ios}
- It is given by,

$$I_{ios} = |I_{b1} - I_{b2}|$$



Input Offset Voltage

- Input **offset voltage** is the differential **voltage** which is required to apply between the two terminals of the **op-amp** such that the **output** of the **op-amp** will become zero when no input is applied to the **op-amp**
- **Output offset voltage** is the multiplication of DC gain and the input **offset voltage**

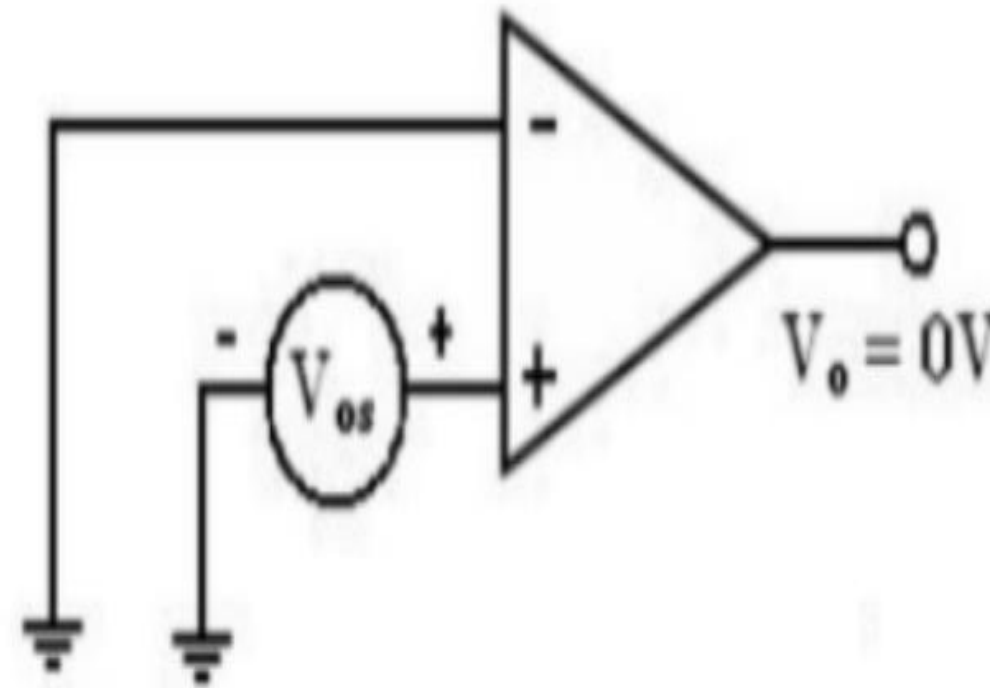



Thermal Drift



- **Thermal drift** is the changes in the normal operational behaviour of a device due to changes in ambient temperature
- **Drift** caused by internal heating of equipment during normal operation or by changes in external ambient temperature
- There are very few circuit techniques that can be used to minimize the effect of drift
- Careful printed circuit board layout must be equal be used to keep op-amps away from source of heat
- Forced air cooling may be used to stabilize the ambient temperature



THANK YOU