

SNS COLLEGE OF TECHNOLOGY

Coimbatore-35
An Autonomous Institution



Accredited by NBA – AICTE and Accredited by NAAC – UGC with 'A++' Grade(III Cycle)
Approved by AICTE, New Delhi & Affiliated to Anna University, Chennai

DEPARTMENT OF ELECTRONICS & COMMUNICATION ENGINEERING

23ECB202 – LINEAR INTEGRATED CIRCUITS

II YEAR/ IV SEMESTER
1

UNIT 2 – APPLICATIONS OF OPERATIONAL AMPLIFIERS

TOPIC 4 – Instrumentation amplifiers



Guess?????



+





Why instrumentation amplifier?



- To amplify small signals in the presence of noise has gone through an evolution over the years
- The simplest approach, the discrete operational amplifier, isn't suitable as an instrumentation amplifier
- An instrumentation amplifier is used to amplify very low-level signals, rejecting noise and interference signals



What is an instrumentation amplifier?



- An instrumentation amplifier is used to amplify very low-level signals, rejecting noise and interference signals
- Inputs to the **instrumentation amplifiers** will have very low signal energy
- High gain and accurate
- High CMRR



Instrumentation Amplifier using Op Amp



- Op-amps 1 & 2 are non-inverting amplifiers
- Op-amp 3 is a difference amplifier
- Instrumentation amplifier's final output V_{out} is the amplified difference of the input signals applied to the input terminals of op-amp 3
- Let the outputs of op-amp 1 and op-amp 2 be V_{o1} and V_{o2} respectively

$$\text{Then, } V_{out} = (R3/R2)(V_{o1}-V_{o2})$$

- The potential at node A is the input voltage $V1$. Hence the potential at node B is also $V1$, from the virtual short concept. Thus, the potential at node G is also $V1$



Activity

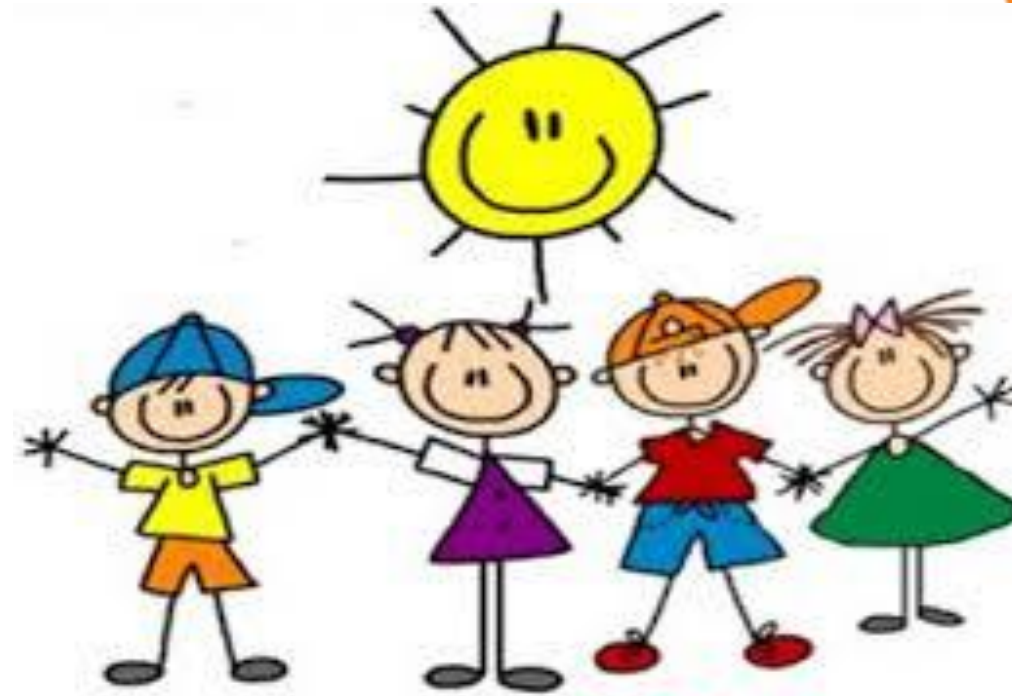

In class activity

Students should make the correct shape from the given tangram kit.



Input Stage



- ❖ The circuit is divided into two stages.
- ❖ The input stage has two non-inverting buffer amplifiers
- ❖ The input-stage amplifiers also provide high impedance, which minimizes loading of the sensors.
- ❖ The gain-setting resistor (R_G) allows the designer to select any gain within the operating region of the device.

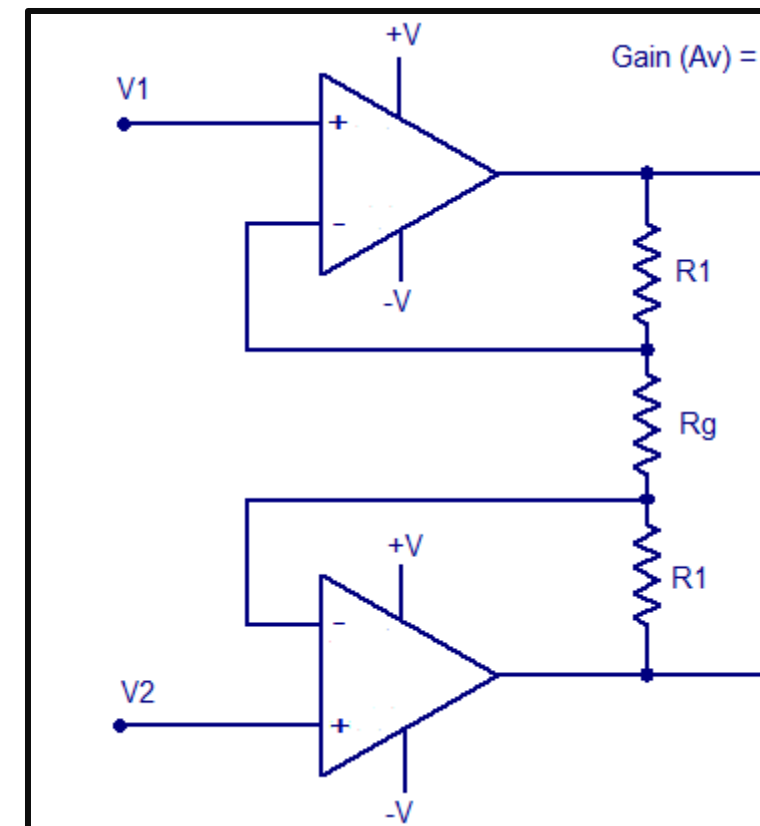



Output Stage

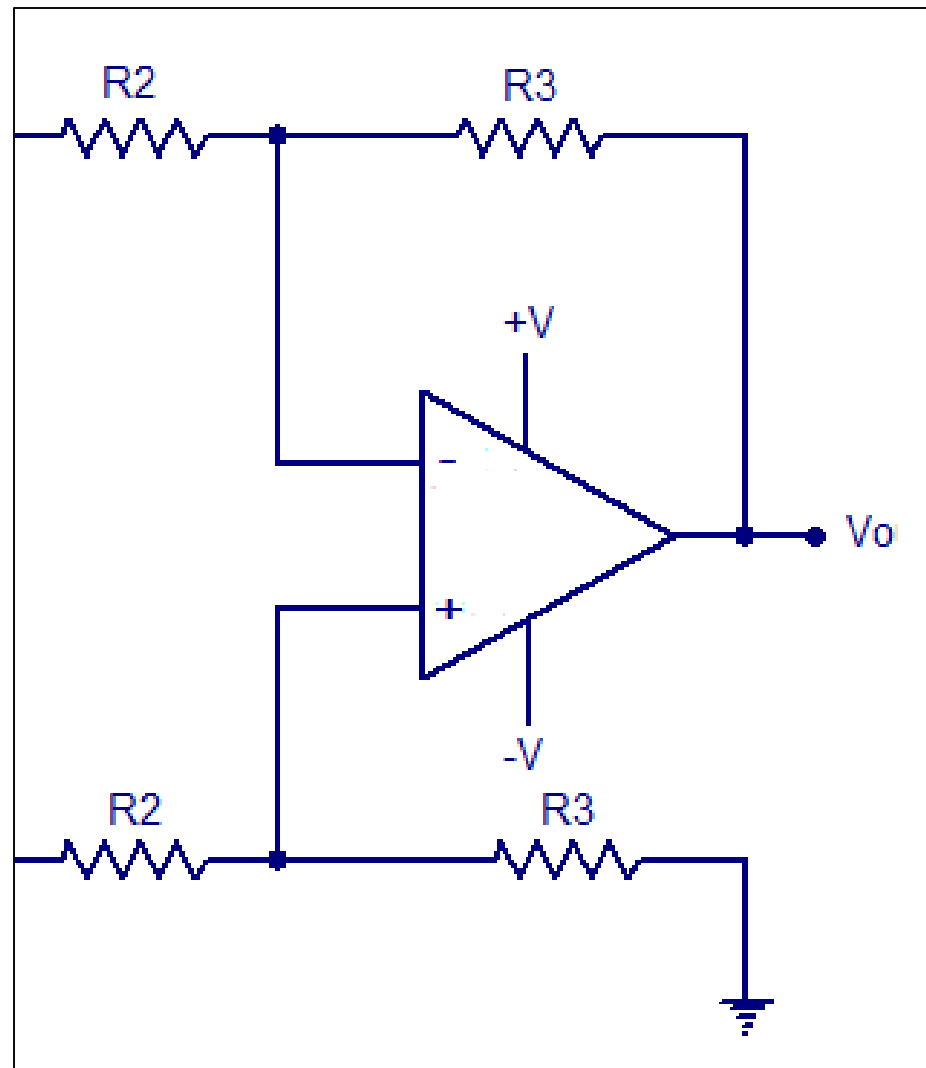

- ❖ The output stage is a traditional difference amplifier.
- ❖ The ratio of internal resistors, $R2/R1$, sets the gain of the internal difference amplifier
- ❖ Typically $G = 1 \text{ V/V}$ for most instrumentation amplifiers
- ❖ The balanced signal paths from the input to the output yield excellent CMRR.



Instrumentation Amplifier

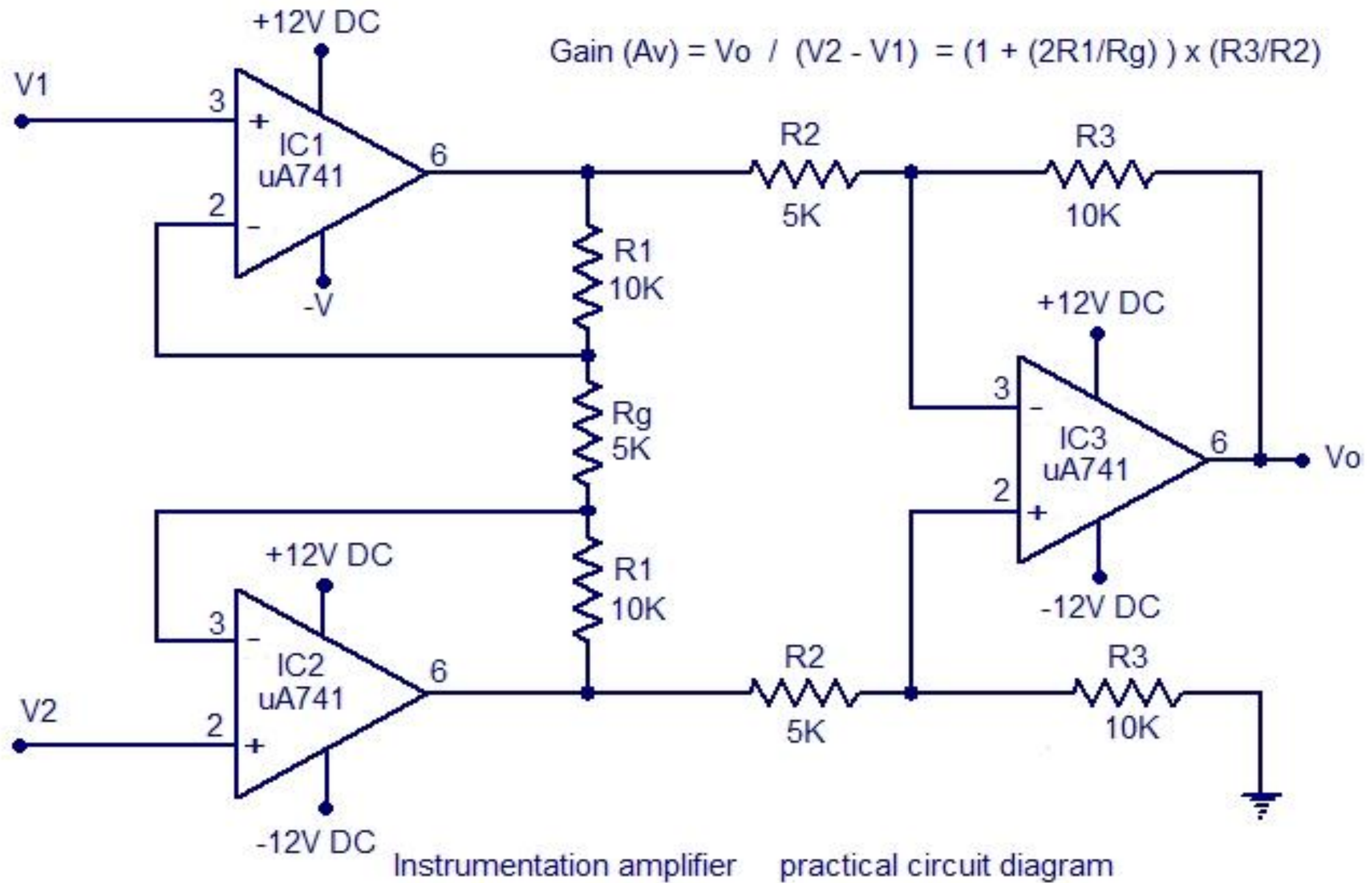



Applications



EEG



ECG



BP



Light Intensity Meter



Analog Weighing
scale



Advantages



- Accurate Testing and Measurement
- Stable and Easy to Use
- Reliability of the Setup and Results
- Highly Scalable



Disadvantages



Long Range Transmission Issues

- Superimposing of the original wave when the sound or noise gets transmitted over a long range.
- The system will depend on special cables that can cancel this noise or superimposition



Assessment



1. An instrumentation system does not include

- a) Transducer
- b) Instrumentation amplifier
- c) Automatic process controller
- d) Tester

Answer: d

2. Why output of transducer is not directly connected to indicator or display?

- a) Low level output is produced
- b) High level output is produced
- c) No output is produced
- d) Input is fed directly

Answer: a

3. What are the features of instrumentation amplifier?

- a) Low noise
- b) High gain accuracy
- c) Low thermal and time drift
- d) All of the mentioned

Answer: d





THANK YOU